

Laser Sources for Metrology and Machine Vision

Laser diode based laser sources for high precision measurement and inspection systems

by Dr. Ulrich Oechsner, Dr. Christian Knothe, Mats Rahmel and Michael Schulz

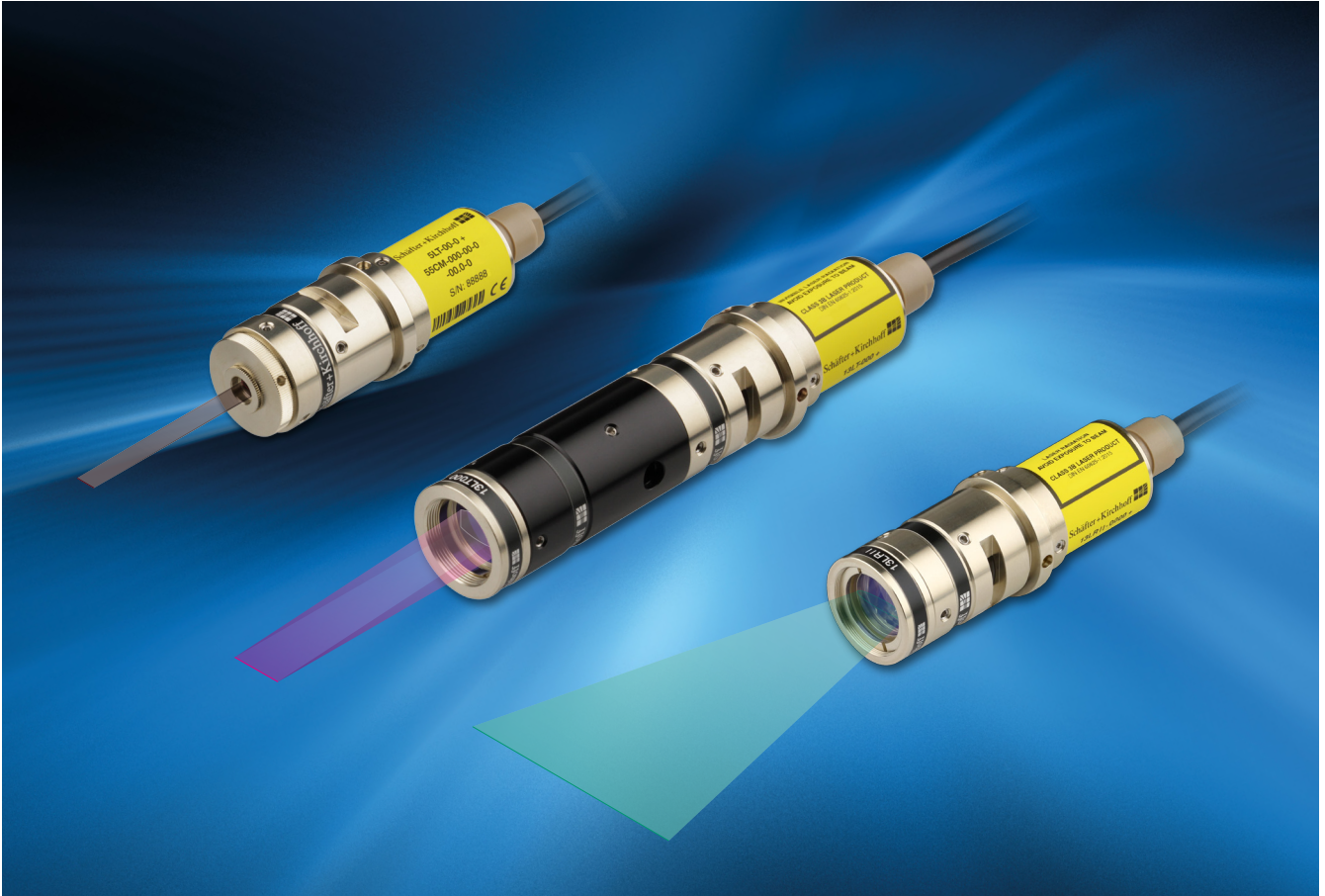

Fig. 1:

The laser sources shown combine a laser diode with refractive and sometimes diffractive optics to achieve the required beam shape. The form and shape of the beams reflect the broad variety of their application including laser lines ideal for e.g. triangulation and laser light sectioning, semi-telecentric beams predestined for e.g. laser diffraction and laser spots e.g. for particle counting and sizing. Even within the basic groupings of laser line, laser spot or collimator, there are variants that differ widely in their physical characteristics.

Modern measuring techniques often involve using lasers specifically designed for the demanding requirements of industrial tasks. An increasing number of laser diodes have become available in the green and blue region of the visible spectrum so that laser-diode based modules now cover the full range from UV to IR. A variety of beam-shaping techniques can be used to produce the particular beam profile necessary for a specific measuring task.

What are Laser Lines and Spots used for?

One possible application is laser triangulation, also called laser light sectioning, and it is the most common application of a laser line. It is a 3D measuring technique for determining a profile at a predefined incident section (Fig. 2). The imaging camera is mounted directly perpendicular to the scanned object. It measures the lateral displacement and distortion of the incident laser line projected at an angle onto the object. The recorded camera image contains all of the height information obtained from the section defined by the incident laser beam, which is then decoded to provide the 3D height profile as the object passes through the laser line camera detection system.

The depth of the measuring area and its resolution are determined by the triangulation angle between the planes of the dissecting laser line and the optical axis of the camera lens. Larger angles of the dissecting incident laser line produce the greatest range in recordable height variations.

Particle counting and measuring is another important application which uses laser lines or laser spots. In the most simple setup a detector registers the light reflected by a particle passing through the laser beam.

Other applications make use of the smallness of a laser diode emitter. With a typical emitter size of $1\ \mu\text{m} \times 3\ \mu\text{m}$, singlemode laser diodes combined with long focal optics result in large laser beams with very small divergence (typical $0.03\ \text{mrad}$). These laser sources are used for width and gap measurements, using simply the shadow, or in more sophisticated cases the diffraction pattern of the object placed into the beam.

Beam Characterization

Laser lines, e.g., are primarily characterized by their length, width and working distance. The measurement resolution is often determined by the line width and can be limited by laser speckle. A sufficient depth of focus has to be taken into account when measuring objects of variable height. The fan angle of the laser can also be decisive in the choice of laser line. A large fan angle is required for long lines at short distances.

A so-called semi-telecentric laser line, with zero fan angle, might be appropriate in case of a glossy

surface and a reflection based measurement technique. In addition there are other important parameters, like wavelength, coherence length, output power, and power noise, which have to be considered before a laser source is selected for a specific measurement task. Some of these aspects are subsequently discussed in more detail.

Wavelength

Laser sources based on laser diodes are available in wavelengths from 375 nm in the near UV to over 2300 nm in the infrared. For most inspection systems, the usable wavelengths are limited by the sensitivity of the camera to the visual spectrum range 400-700 nm plus the shorter end of the near infrared (up to about 1000 nm). Within the visual range the wavelength is further limited to the wavelengths available as laser diodes. There are still some gaps in the spectrum, on the market are violet (405 - 410 nm), blue (415 - 488 nm), green (515 - 520 nm), and red (635 - 690 nm)

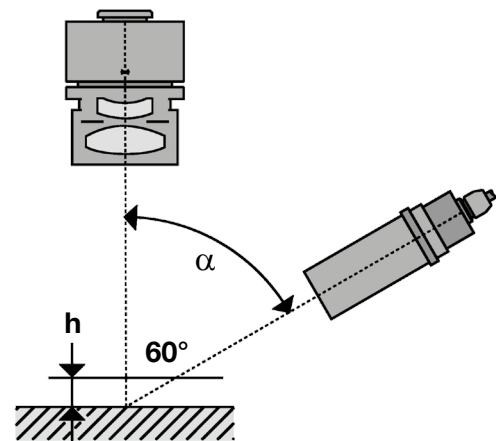

Fig. 2a:
Profiling an object with laser triangulation.

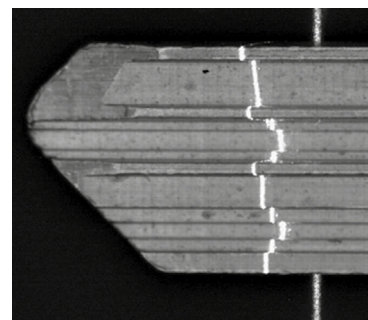

Fig. 2b:
Image obtained from the camera. The relative displacement of the laser line provides information about the object height at that point.

laser diodes. Violet or blue are often used when very thin lines or small spots are required, and depth of focus is not important. Most other applications still work with red lasers, where the price-performance-ratio is optimal.

within the laws of physics for each case.

But thin laser lines are limited by their small depth of focus. The line width increases and the power density falls drastically when the line is out of focus (Fig. 3a).

Micro and Macro Laser Lines

Thin laser lines are often preferred in order to maximize the signal intensity at the sensor. Sometimes they are even necessary, if the required resolution is small compared to the width of standard laser lines. If a laser line is very near to the diffraction limited ideal of a focused Gaussian beam, we call it a Micro Laser Line. The line width still depends on parameters like wavelength and working distance, but these lines provide the smallest possible line width

The range around the nominal working distance, in which the laser line does not increase by more than a factor 1.41, is usually specified as the depth of focus of that laser line. For a Micro Laser Line of width B and wavelength λ it is given by the so called Rayleigh range (twice the Rayleigh length z_R), defined by

$$2z_R = \frac{\pi B^2}{2\lambda}$$

For a 660 nm (red) laser line with 10 μm line width, e.g., the Rayleigh range is only 0.15 mm. This is definitely not suitable if, e.g., height variations of 1 mm

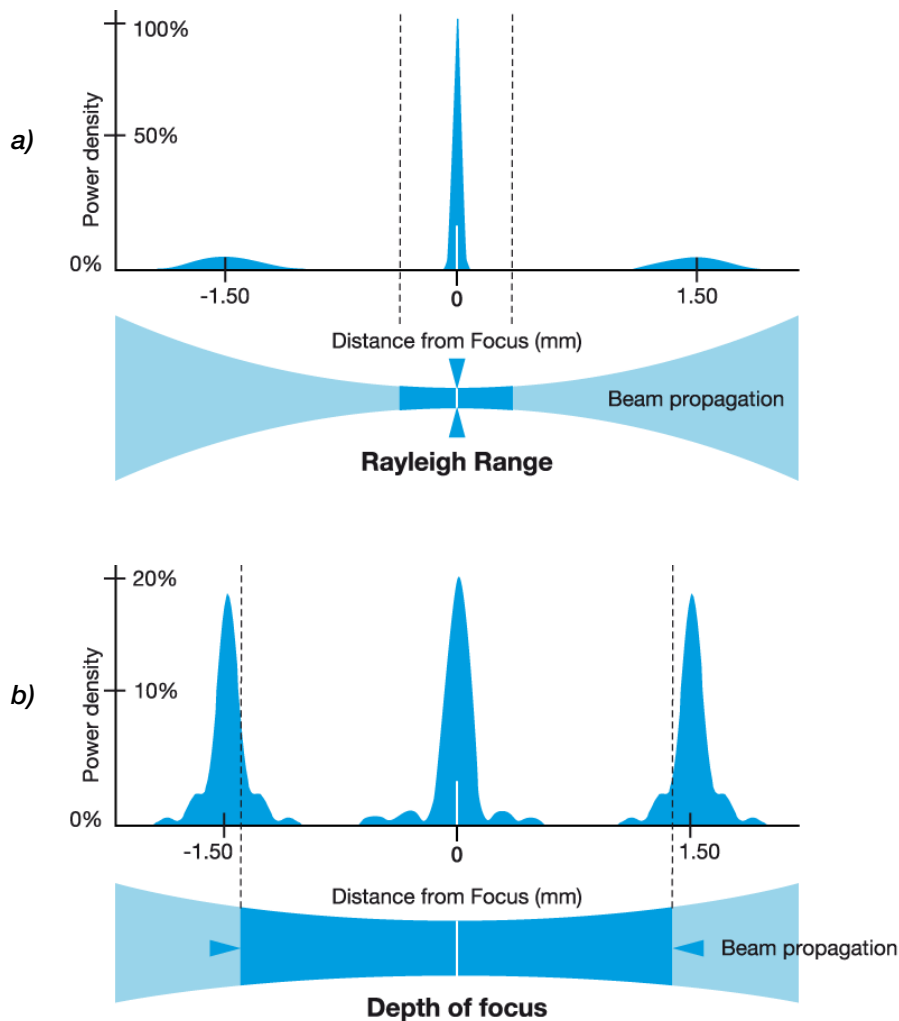

Fig. 3: *Micro lines (a) exhibit a high power density at the focus, but line width increases and power density decreases considerably outside this point. Macro lines (b) have a lower power density but an extended depth of focus (approx. 7-40 times larger).*

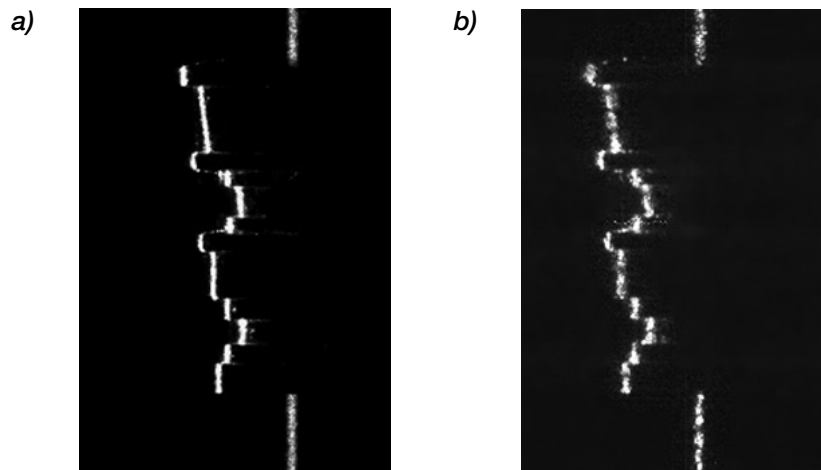

Fig. 4:

Figure 4: Laser speckle behavior imaged with a small f-number $k=2.8$ (a) and with a large f-number $k=22$ (b).

are to be measured with laser triangulation. So called Macro Laser Lines have an extended depth of focus. Within the depth of focus range, the intensity profile across the laser line is approximately Gaussian, the side lobes caused by diffraction remain below the 13.5% intensity level within the depth of focus range (Fig 3b). For a macro laser line with width B and wavelength λ , the depth of focus $2z_M$ is defined as

$$2z_M = 1.75 \frac{\pi B^2}{2\lambda}$$

For a particular line width B , the depth of focus of a macro line is almost twice that of the equivalent micro line. At the same working distance macro lines are 2 - 5 times wider than micro lines, leading to a depth of focus extended by a factor of approx. 7 - 40.

Laser Speckle

Laser speckle arise from multiple interference, caused by, e.g., diffuse reflection of laser radiation on optically rough surfaces (height variations $> \lambda/4$).

A laser beam observed directly with, e.g., the camera of a beam profiling system appears smooth. If the same beam is directed to a rough surface and then imaged onto the camera sensor, the typical speckle intensity pattern appears.

The speckle contrast and size generally depends on the spot size and the size of the aperture of the optics as well as the measurement geometry. In case of a laser line, laser speckle disturbs the homogeneity

of the imaged laser line. The granularity of the laser speckle depends on the aperture setting of the objective used to image the laser line. With a small f-number (large aperture), the generated speckles have a high spatial frequency and produce a more homogeneous image (see Fig. 4a), whereas the speckles are more granular and particularly disturbing when using a larger f-number (i.e. smaller aperture, see Fig. 4b).

The generation of laser speckle in most cases cannot be avoided. The principle of laser light-sectioning (e.g.) relies upon the imaged surface being roughly textured and diffusely reflecting optically.

A substantial reduction in the speckle effect can be achieved by:

- choosing large lens apertures (small f-numbers) for the objective lens, which reduces speckle size, at the expense of a reduced depth of focus (Fig. 4),
- using a laser beam source with decreased coherence length, such as a superluminescent diode or a laser of the LNC-Series.

Laser Diode Modules with Low Noise and Reduced Coherence

Conventional singlemode laser diodes are semiconductor lasers and usually operate on one favored longitudinal mode. However, the semiconductor laser material exhibits a temperature

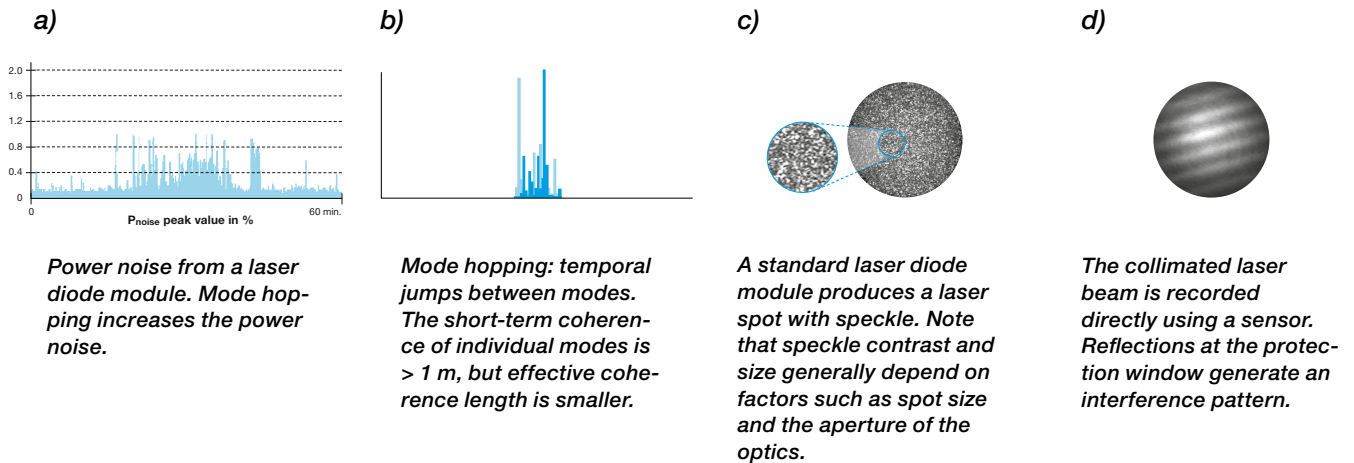

Fig. 5:
Characteristics of a standard laser diode beam source. High noise, mode hopping, laser speckle and unwanted interference can constrain the optical resolution.

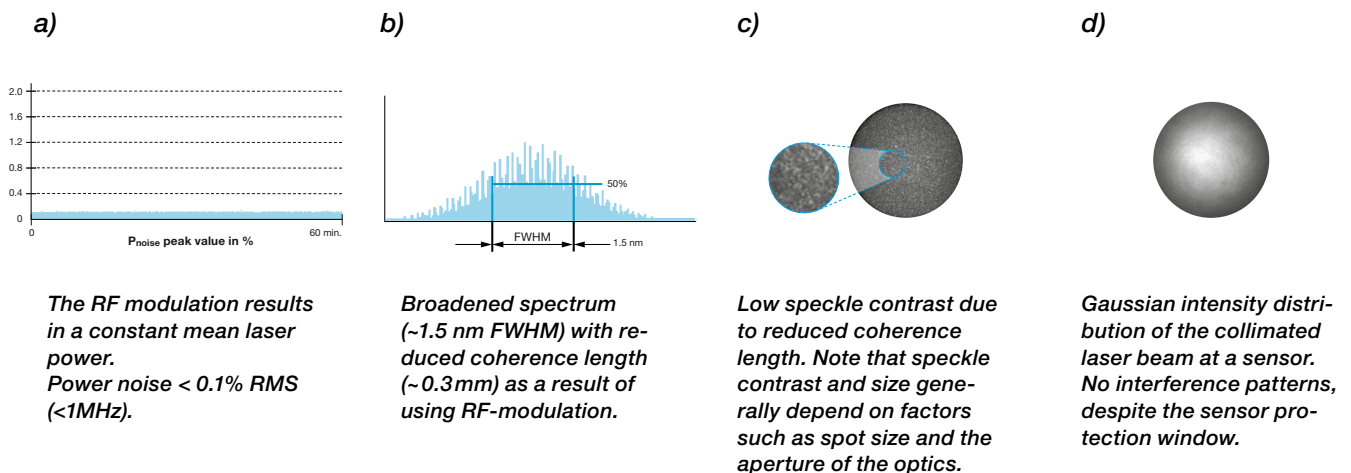

Fig. 6:
Advantages of the low noise laser diode beam source with lower noise a), spectral broadening b), reduced laser speckle c) and less interference d).

dependency, which alters the gain profile and refractive index so that the diode jumps between different longitudinal modes.

This mode hopping causes the output wavelength to jump rapidly by a few picometers. For singlemode diodes that are not temperature stabilized, the output power can change erratically by as much as 3%.

The undesirable features of power noise and mode hopping are eliminated in the low noise laser diode module LNC-series by modulating the current of the laser diodes at a high frequency. This RF-modulation excites numerous longitudinal modes of emission

while simultaneously lowering signal noise significantly, to $< 0.1\% \text{ RMS}$. This induced broadening of the spectrum, in a controlled and stable way, has the added advantage of considerably reducing the coherence length of the laser beam which, in turn, reduces laser speckle contrast and prevents interference patterns.

The notable benefits of RF-modulated laser diodes become more evident when compared with the undesirable characteristics of a standard laser diode.

The noise, spectrum, laser speckle as well as interference behaviour are all improved for the low

noise laser diode module, Fig. 6, in comparison with a standard laser diode, Fig. 5.

Low Noise

In Fig. 5a and 6a, the noise profiles (bandwidth of 1MHz, period of 60 minutes) of the two diodes are compared. Peak noise values exceed 1 % for a standard laser diode while the RF-modulation of the low noise laser diode module reduces noise to <0.1 %, a value close to the limit of detection.

No Mode Hopping

Without RF-modulation, the laser jumps stochastically between several emitting modes (Fig. 5b, different colors). Upon RF-modulation, numerous modes are excited within the gain profile of the resonator (Fig. 6b), producing a broad spectrum with about 1.5 nm FWHM (full-width at half-maximum).

Reduced Laser Speckle

The corresponding laser speckle behavior is shown in Fig. 5c and 6c. For thicker laser lines and larger laser spots when using a fully coherent laser source, the laser speckle contrast is 1 and there are areas of zero intensity within a laser spot.

The emission from multiple laser modes results in the coherence length of a low noise laser diode being reduced, to <300 μm , and the speckle contrast and size are also less (compare Fig. 5c with Fig. 6c).

It should be noted that this benefit is less relevant for thinner laser lines and smaller laser spots. With a thin laser line of e.g. 10 μm , there is not much coherence length required for laser speckle to appear.

Less Interference

Another effect of a reduced coherence length can be observed in Fig. 5d and 6d. The recording of a collimated laser beam reveals a disturbing interference pattern when using a standard laser diode (Fig. 5d), as a result of internal reflection within the protective glass window of the detector in an area scan camera.

Since the coherence length of a low noise laser diode module is less than the thickness of the glass then the interference is eliminated (Fig. 6d).

Product Configurator

The new online product configurators for laser line generators or laser spots and collimators allow to insert laser parameters like desired line length or width, wavelength as well as the intensity profile (Gaussian or uniform) amongst many other parameters. The product configurator narrows down the search quickly and easily to the most relevant options in order to find the most adequate laser for each application.

Summary

Laser lines and laser spots are used for a large variety of applications, e.g., laser lines for 3D measurements. Depending on the prerequisites for depth of focus of the laser line, either micro lines with a high power density and smaller depth of focus or macro lines with larger line width and increased depth of focus are appropriate. Special variants with low noise and reduced coherence length can improve the measurement results. The online product configurators on the new Schäfter+Kirchhoff website provide information on each laser quickly and easily and help narrow down the search to the most relevant choices.