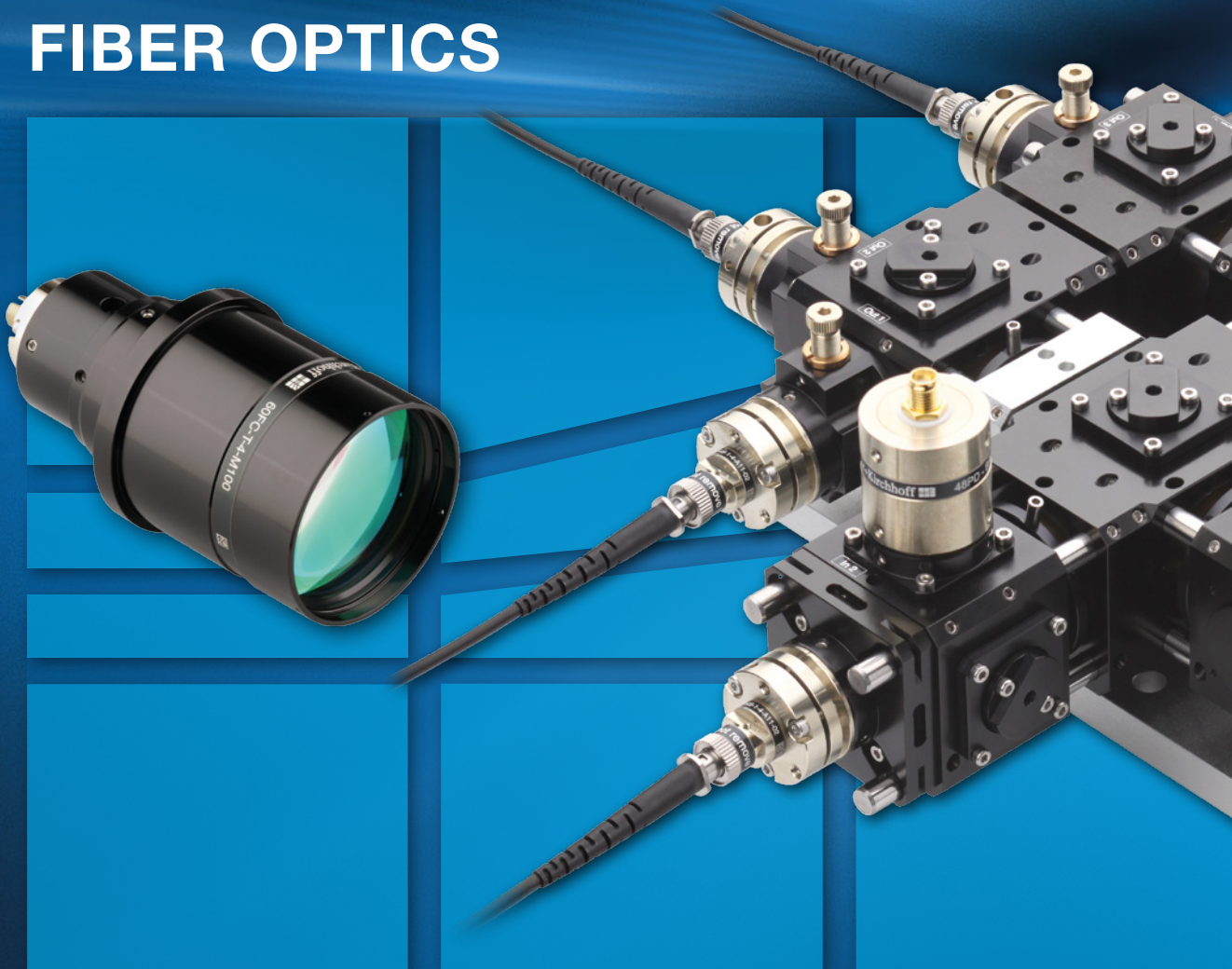


FIBER OPTICS



Polarization-maintaining · Fiber Couplers · Fiber Cables · Fiber Optic Components

■ Quality and Reliability

Schäfter+Kirchhoff GmbH is based in Hamburg, Germany. From here we manufacture high quality optical products that are delivered to customers all around the world.

The company was founded over 60 years ago, and began with classical lens design and customized optical solutions. The focus has shifted gradually towards the current three product lines: polarization-maintaining fiber optics, laser lines and line scan cameras.

A major focus is our winning combination of high optical and mechanical precision, which is the basis for the high quality, stability and durability of our products. We are committed to providing the highest quality and reliability possible, a goal continuously improving because of our quality control system. Schäfter+Kirchhoff GmbH is certified according to the ISO 9001 standard.

Our extensive know-how and our highly qualified and strongly committed employees are the driving force behind the company. To have sales, research and development, as well as manufacturing so closely knit together, ensures a quick and efficient response to customer needs.

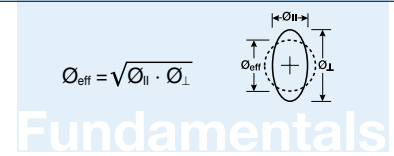
After 60 years of private ownership, Schäfter+Kirchhoff GmbH was transferred in 2016 to the Gregor Federau Foundation, which was established by the former owner of the company to support child and youth welfare.

Contents

Fiber Couplers: Incouplers and Collimators

11

Fundamentals	12
Selection criteria	14
TechInfo: Long term stability	15
Product Configurator	16
Overview	17

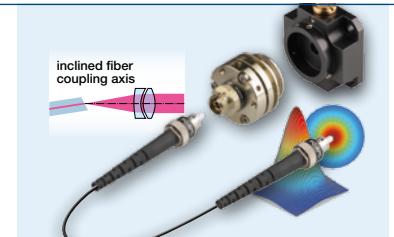


Laser Beam Couplers

Laser Beam Couplers 60SMF

for coupling into single-mode and polarization-maintaining fibers 18

Optics options, Order options	18
Dimensions	19
Adapters, adjustment and adjustment tools	19
Assembly and adjustment	20
60SMF Fiber Coupling Sets	22



Fiber-fiber Couplers 60FF / FF-T / FF-F

for interconnecting two single-mode fibers or polarization-maintaining fibers 23

Dimensions	23
Order options	23

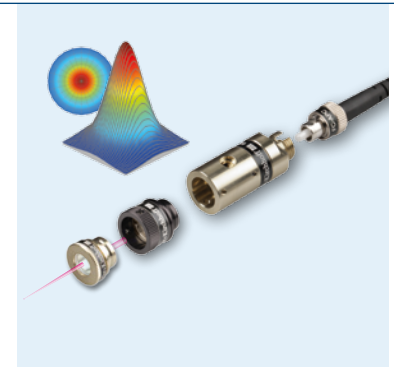


Fiber Collimators

Fiber Collimators 60FC

for collimating laser radiation exiting an optical fiber or for coupling a collimated beam into an optical fiber 25

Optics options	25
Dimensions	25
Assembly and adjustment tool	25
Order options	25
Attachment optics:	
Micro focus optics type 5M	26
Polarization filters type 5PF	27
Retardation optics type 5WP	27
Iris diaphragm type 5BL and pinholes type 5H	28
Adapters and holder	28



Fiber Collimator 60FC-...-XV for flushing

Special series with bore hole for flushing purposes 29

Optics options	29
Assembly and adjustment tools	29
Dimensions, order options and adapter	29



Fiber collimators 60FC-L, 60FC-T

for collimating radiation exiting from an optical fiber to a large beam diameter 30

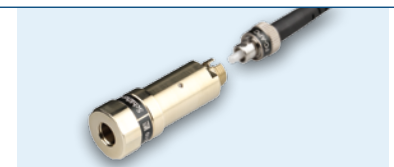
Optics options	30
Order options	30
Dimensions, assembly and adjustment tools	31
Tilt adjustment for type 60FC-T	32
Accessories and attachment optics:	
Clamp collars CC	32
Micro focus optics type 13M and 25M	33
Polarization filters type 13PF	34
Iris diaphragms type 13BL, 13H, 25BL, 40BL	34



Fiber Collimators 60FC-SF with super-fine focussing mechanism

Focus adjustment with super-fine thread 35

Optics options	35
Dimensions, order options and adjustment tools	36
Adapter and holder	36



■ Contents (continued)

Couplers and Collimators for Special Applications

 <p>Special fiber collimators for quantum optics</p> <p>Adjustment of left-handed and right-handed circular polarization.</p>	<p>Fiber Collimators 60FC-Q with Integrated Quarter-wave Plate</p> <p>Circularly polarized laser radiation 37</p> <p>Optics options 37</p> <p>Order options 37</p> <p>Typical wavelengths 37</p> <p>Adjustment of the quarter-wave plate 38</p> <p>Assembly and adjustment tools 38</p> <p>Dimensions 38</p>
 <p>Elliptical beam</p>	<p>Fiber collimators 60FC-E for Elliptical Cross-section</p> <p>Polarization linear or optionally circularly polarized 39</p> <p>Optics options 39</p> <p>Order options 39</p> <p>Optical scheme 39</p>
 <p>PCF</p>	<p>Fiber Couplers 60FC-SMA for SMA-905 High Power Connectors with 5° and 8°-polish 40</p> <p>Optics options 40</p> <p>Order options 40</p> <p>Assembly and adjustment tools 40</p> <p>Attaching a polarization-maintaining fiber 41</p> <p>Focus and Tilt adjustment 41</p> <p>Dimensions 41</p>
	<p>Fiber Couplers 60FC-K compatible with kineMatix® Optomechanics 42</p> <p>Optics options 42</p> <p>Assembly and adjustment tools 43</p> <p>Order options 43</p>
	<p>Fiber Couplers 60FC-A-19.5 for coupling into multimode fiber cables 44</p> <p>Optics options 44</p> <p>Order options 44</p>
	<p>Fiber Collimators 60FC-BC and Fiber Collimators 60FC-PD 45</p> <p>Fiber collimators 60FC-BC with dichroic beam combiner:</p> <p>Optical scheme 45</p> <p>Order options 45</p> <p>Fiber collimators 60FC-PD with integrated power monitor:</p> <p>Optical scheme 45</p> <p>Order options 45</p>
	<p>Anamorphic Beam-Shaping Optics 5AN</p> <p>Transformation of collimated laser beams from elliptical into circular 46</p> <p>Dimensions and technical data 46</p> <p>Assembly and adjustment tools 46</p> <p>Order options 46</p> <p>Fundamentals: Beam-Shaping and coupling into single-mode fibers 47</p>
	<p>Expansion Optics 48EO</p> <p>Expands the beam diameter of the collimated beam 47</p> <p>Order options 47</p> <p>Dimensions 47</p>

Fibers Fundamentals 50
 Fiber connectors Fundamentals 52
 Product Configurator 53

$$\sigma_{\text{spot}} = \frac{f_{\text{micro focus}}}{f_{\text{collimator}}} \text{ MFD}$$

Fundamentals

Polarization-maintaining Fiber Cables PMC 54
 Standard polarizaion-maintaining fiber cables PMC 54
 Order options 54

PM-Fiber

Optional: End Caps

Single-mode Fiber Cables SMC 55
 Standard single-mode fiber cables SMC 55
 Order options 55

SM-Fiber

Optional: End Caps

Multimode Fiber Cables MMC 56
 Multimode fiber cables MMC 56
 Order options 56
 How to find the adequate fiber collimator 56
 Fundamentals 57

Multimode Fiber

Vacuum Feed-throughs
 Polarization-maintaining, single-mode or multimode fiber cables 58
 Standard vacuum feed-through V 58
 Multiple vacuum feed-throughs V 58
 Dimensions 58
 Order options 58

Optional: End Caps

Casing Feed-throughs 59
 Standard casing feed-throughs CFT 59
 Dimensions 59
 Order options 59

Optional: End Caps

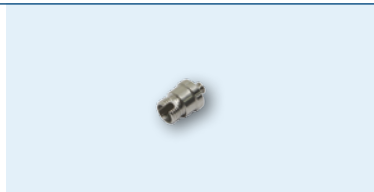
PCF Broadband Fiber Cables 60

With End Caps

■ Contents (continued)

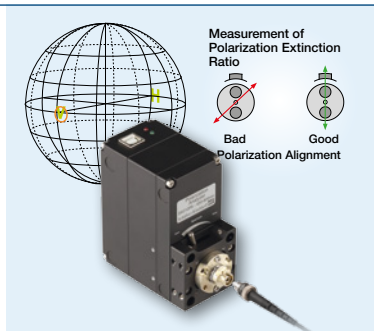


Bulkhead Fiber Adapters	61
Overview and order options	61
Dimensions	62



Accessories	63
Fiber connector cleaning tool	63
FC Mating sleeves	63
FC protection caps	63

■ Measurement Tools 65



Polarization Analyzers SK010PA	
Universal measurement and test system for laser beam sources with polarization-maintaining fiber cables	66
Order options	66
Dimensions	67
Analysis software SKPolarizationAnalyzer	67
Different fields of use for the polarization analyzer	68
Configurations and accessories	70

■ Multicube™ – Components and Systems 73



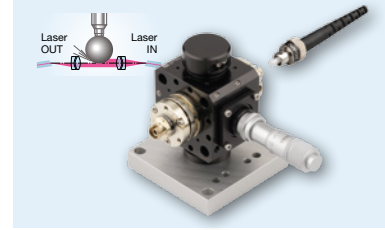
Construction Kit Multicube™ – Multicube™ System	74
Combination cubes and plates 48MC:	
Cubes	75
Mounting plates	75
Optics for the multicube™ system:	
Beam splitters	76
Beam combiners	77
Polarizers	77
Retardation optics / dichroic retardation optics	78
Photo detectors	78
Accessories: flanges, adapters and tools	79

Multicube™ – Systems 81

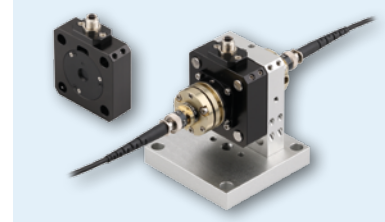


Fiber-coupled Faraday Isolators	81
--	----

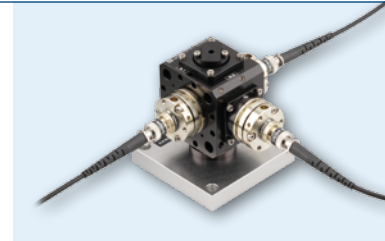
Laser Attenuators 48AT	82
Laser attenuators 48AT	82
Calibration curves and order options	82
48AT-F with monitor diode	82
48AT-MD with motorized drive	82



Electro-magnetic Laser Shutters 48EMS	83
Order options	83
Dimensions, electrical scheme	83
Shutter control unit SK97121C	83



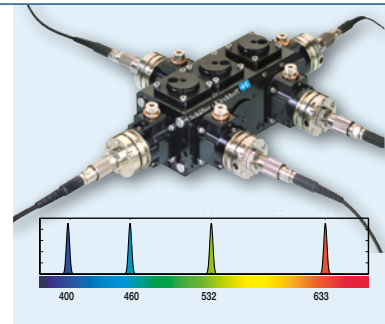
Beam Splitters and Combiners	84
Beam Splitters:	
Example Configurations	84
Order options	84
Beam Combiners:	
Example Configurations	85
Order Options	85



RGBV Laser Beam Combiners	86
Systems for combination of (405), 460, 532 and 660 nm laser radiation into a single fiber-coupled beam	

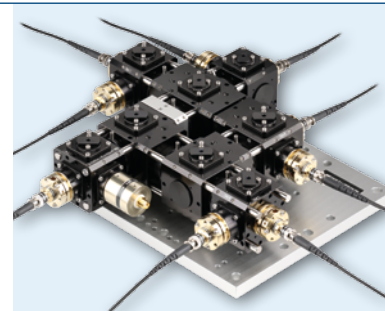


RGB laser beam combiner	86
RGBV laser beam combiner	87



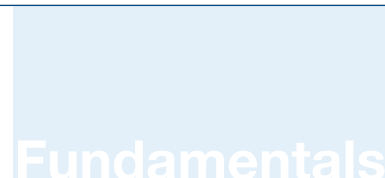
Fiber Port Clusters 89

Compact, rugged and highly efficient opto-mechanical units for splitting/combining multiple ports	90
Fiber port cluster	90
Example: Fiber Port Clusters 2 → 6 48-FPC-2-6-xxx	91
Optical Setup and Order options	91
Dichroic Fiber Port Clusters	92
Example Configurations	92
Order Options	93



Fiber-Coupled Low Coherence Laser Sources 95

Fundamentals	96
Overview	97
Applications	97

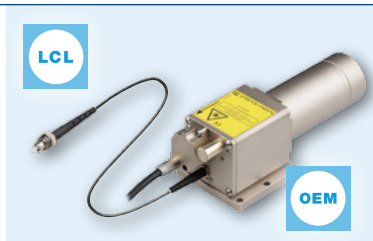


■ Contents (continued)

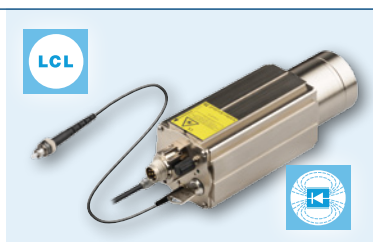
■ Fiber-Coupled Low Coherence Laser Sources 95



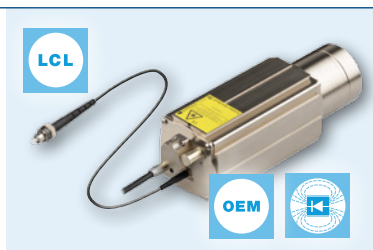
Laser Diode Beam Sources 51 nano-S	98
Order options	98
Dimensions	98



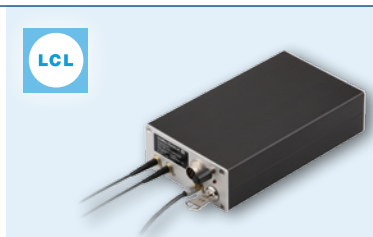
Laser Diode Beam Sources 51 nano-N	99
OEM version without key switch and interlock	
Order options	99
Dimensions	99



Laser Diode Beam Sources 51 nano-FI-S	100
with integrated Faraday Isolator	
Order options	100
Dimensions	100



Laser Diode Beam Sources 51 nano-FI-N	101
OEM version with integrated Faraday Isolator, without key switch or interlock	
Order options	101
Dimensions	101



51 nanoC-S: Low Coherence Fiber-coupled Laser Sources	102
With multiple fiber output ports	
Order options	102
Dimensions	102

Electrical data and Accessories	103
Electrical data	103
Accessories	103

■ Fiber-Coupled Laser Sources 105

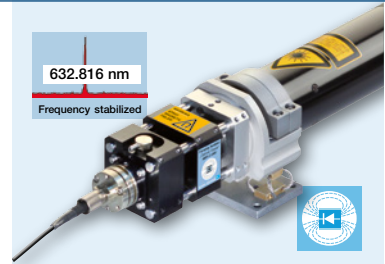


Laser Diode Beam Sources 58FCM	
fiber-coupled with single-mode and polarization-maintaining fibers	106
Order options	106
Dimensions	107
Electronics and accessories	107

Fiber Coupling Sets for HeNe Lasers	108
Selection criteria	108
Laser Beam Couplers and Fiber Cables for HeNe laser	108
Adapters, Mounting consoles and Adjustment tools	108



Fiber Coupling Sets with integrated Faraday Isolators	
For Frequency-stabilized HeNe Lasers	110



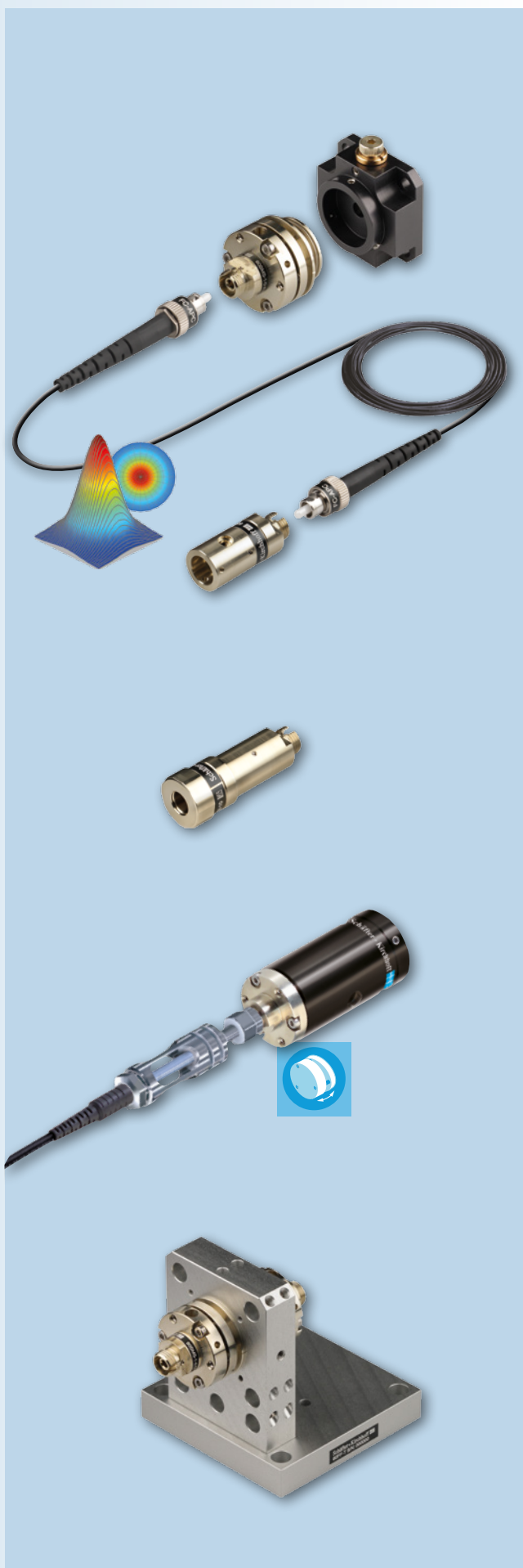
■ Laser Safety 113

Laser Safety	114
Laser safety goggles	115
Laser Classes EU Standard	116



Fiber Couplers

Fiber Couplers and Collimators are used for collimating laser radiation exiting an optical fiber or for coupling a collimated beam into an optical fiber cable.



■ Fiber Couplers: Incouplers and Collimators

Fundamentals	12
Selection Criteria	14
Product Configurator	16
Laser Beam Couplers 60SMF	18
60SMF Fiber Coupling Sets	22
Fiber-Fiber Couplers 60FF	23
Fiber Collimators 60FC	25
Fiber Collimators 60FC-...-XV for flushing	29
Fiber Collimators 60FC-L, 60FC-T	30
Fiber Collimators 60FC-SF with Fine-focussing Mechanism	35
Fiber Collimators 60FC-Q... with integrated Quarter-wave Plate	37
Fiber Collimators 60FC-E for Elliptical Cross-Section	39
Fiber Couplers 60FC-SMA for SMA-905 High Power Connectors	40
Fiber Couplers 60FC-K	42
Fiber Couplers 60FC-A-19.5	44
Fiber Collimators 60FC-BC / 60FC-PD for Special Applications	45
Anamorphic Beam Shaping Optics 5AN	46
Expansion Shaping Optics 48EO	47



Technotes and Fundamentals

For more information, please refer to the extensive technotes section on:
www.sukhamburg.com/support/technotes.html

Numerical Aperture NA

The numerical aperture NA of the optics is defined by its clear aperture. The NAe^2 of a single-mode fiber is given at its $1/e^2$ level.

The NA of the coupling optics must be larger than the specified NAe^2 of the fiber. Otherwise the beam is truncated by the optics and the fiber coupling efficiency is reduced.

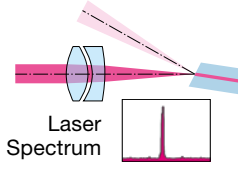
Inclined or coaxial axis

Single-mode fibers with 8°-inclined polish (APC) avoid back-reflected radiation into optical path and are used with Schäfter + Kirchhoff laser beam couplers or fiber collimators that have an inclined coupling axis.

Coupling efficiency or beam quality is not compromised by using components with an inclined axis.

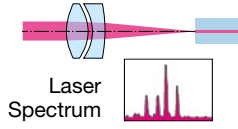
Fiber Coupler with inclined fiber connection

Inclined laser beam couplers / collimators ensure a coupling efficiency as high as those using a coaxial coupling axis with 0°-polish. Back-reflection into the laser system is suppressed and the laser spectrum does not change.



Fiber Coupler with coaxial axis

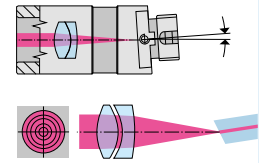
About 8% of radiation is reflected back into the laser system, which can cause multimode emission and optical noise.



Fiber Collimator with inclined fiber connection

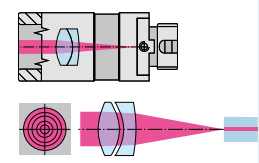
The design of the inclined fiber connection of this fiber collimator compensates for the beam deflection.

The collimated beam is centered, Gaussian and concentrically symmetric.



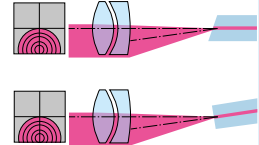
Fiber Collimator with coaxial fiber connection

The collimated beam is centered, Gaussian and concentrically symmetric.



Combination Mismatch

When a combination mismatch occurs, either between an 8°-polish fiber inappropriately attached to a coaxially coupled fiber collimator or vice versa, a 0°-polish fiber connected to an inclined coupled fiber collimator, then the resultant beam is axially displaced, asymmetric and differs significantly from a Gaussian profile.

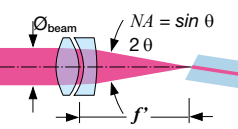


Fundamentals for Coupling into a Fiber

For fiber coupling, either the laser beam couplers type 60SMF or the collimators of type 60FC can be used. If a collimator is selected then it can be used for fiber-coupling by using it in reverse mode and placing it in an adjustable mirror mount (or other mechanics providing the same degrees of freedom). This gives all degrees of freedom to achieve a high coupling efficiency.

Selection of coupling focal length

Maximum coupling efficiency is achieved for an ideal Gaussian beam ($M^2 = 1$, no astigmatism) when the convergence of the focused, circular beam equals the effective NAe^2 of the fiber. Then the laser spot on the fiber end face equals the mode field diameter MFD of the single mode fiber.



Except for an 8% loss from Fresnel reflection at the entrance into and exit from the fiber, an ideal Gaussian beam is transported completely.

For a specified effective fiber NAe^2 the optimum focal length of the laser beam coupler at a given beam diameter \varnothing_{beam} (defined at its $1/e^2$ -level) is given by

$$f' = 0.5 \cdot \varnothing_{beam} / NAe^2.$$

If the effective NAe^2 of the fiber is not known, then the optimum focal length f' can be calculated from the nominal numerical aperture NA by

$$f' = F_{NA} \cdot \varnothing_{beam} / NA.$$

The nominal fiber NA corresponds to the Gaussian angle distribution at a 1% - 5% level requiring the factor F_{NA} to correct for the different definitions of the NA.

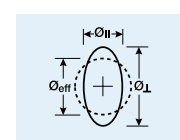
Level	F_{NA}
1 %	0.76
3 %	0.66
5 %	0.61

Example:

Beam diameter: $\varnothing_{beam} = 1.0 \text{ mm}$
 Effective numerical aperture of fiber: $NAe^2 = 0.08$
 Focal length: $f' = 0.5 \cdot 1.0 \text{ mm} / 0.08 = 6.25 \text{ mm}$
 Therefore, select e.g. lens A6.2S with $f' = 6.2 \text{ mm}$

Selection of coupling diameter for an elliptical laser beam

In order to find the best coupling focal length in case of an elliptical beam use the effective beam diameter \varnothing_{eff} which is calculated from the small and the large diameters $\varnothing_{||}$ and \varnothing_{\perp} of the collimated elliptical laser beam:



$$\varnothing_{eff} = \sqrt{\varnothing_{||} \cdot \varnothing_{\perp}}$$

For methods to increase the coupling efficiencies of elliptical laser diode beam sources, see page 47.

Multimode fiber

When using a multimode fiber, the coupling focal length is calculated from the beam diameter and the fiber NA

$$f' = 0.5 \cdot \varnothing_{beam} / NA.$$

A coupling focal length too long can cause insufficient mode mixing, resulting in unwanted beam characteristics, while a focal length too short will reduce the coupling efficiency.

Coupling efficiency

A coupling efficiency of $> 80\%$ is achieved when coupling laser sources with rotationally symmetric beams of high quality ($M^2 < 1.05$) and no astigmatism.

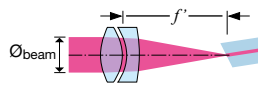
Loss contributions are mainly through:

- Transmission loss in the laser beam coupler ~ 1%
- Imaging aberration, stray loss and beam distortion ($M^2 = 1$) ~ 8%
- Fresnel reflection loss at fiber end faces ~ 8%

Fundamentals for Collimating and Transforming a fiber-coupled Beam into a Spot

Beam Diameter

The collimated beam diameter $\varnothing_{\text{beam}}$ is a function of the collimating focal length f' and the numerical aperture NA of the single-mode fiber.



For a specified fiber NAe^2 , the optimum focal length f' for a given beam diameter $\varnothing_{\text{beam}}$ (defined at its $1/e^2$ -level) is given by:

$$\varnothing_{\text{beam}} = 2 \cdot f' \cdot NAe^2$$

If the effective numerical aperture NAe^2 of the fiber is not known, then the optimum focal length f' can be calculated from the nominal numerical aperture NA using:

$$\varnothing_{\text{beam}} = \frac{1}{F_{NA}} \cdot f' \cdot NA$$

The nominal fiber NA corresponds to the Gaussian angle distribution at a level 1% - 5%, requiring the factor F_{NA} to correct for the different definitions of the NA .

Example:

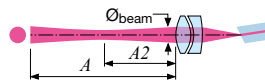
Focal length $f' = 12 \text{ mm}$
 Effective fiber NA $NAe^2 = 0.08$

Level	F_{NA}
1 %	0.76
3 %	0.66
5 %	0.61

$$\varnothing_{\text{beam}} = 2 \cdot 12 \text{ mm} \cdot 0.082 = 1.92 \text{ mm}$$

Pilot Beam with approximate constant beam diameter across working range A

A pilot beam is a Gaussian beam of essentially constant diameter over a particular working range A and is attainable using fine adjustment.



The optimum position of the beam waist is defined as distance $A2$.

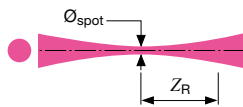
The maximum working range A of a pilot beam is limited because of diffraction:

$$A \leq 2f' + \frac{\varnothing_{\text{beam}}^2 \cdot \pi}{4\lambda}$$

where $\varnothing_{\text{beam}}$ is the collimated beam diameter.

Rayleigh Range

For a Gaussian beam the depth of focus is defined by the Rayleigh range $2 \cdot z_R$ in which the beam waist diameter $\varnothing_{\text{spot}}$ does not increase more than a factor of 1.41.



$$2 \cdot z_R = \frac{2 \cdot \pi \cdot \varnothing_{\text{spot}}^2}{4\lambda}$$

λ = wavelength in μm
 $\varnothing_{\text{spot}}$ = beam waist diameter in μm

Example:

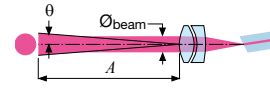
Spot size: $\varnothing_{\text{spot}} = 7.1 \mu\text{m}$
 Wavelength: $\lambda = 780 \text{ nm}$

Rayleigh range:

$$2z_R = \frac{\pi \cdot 7.1^2 \mu\text{m}^2}{0.78} = 20.3 \mu\text{m}$$

Beam Divergence

From principle, a collimated beam has a divergence greater than zero, i.e. the beam diameter varies with distance A from the fiber collimator. The beam divergence θ depends (for large distances of A) on the beam diameter $\varnothing_{\text{beam}}$ at the position of the fiber collimator and on the wavelength λ . Also, the beam diameter depends on the numerical aperture NA of the single-mode fiber and the focal length f' of the collimating lens.



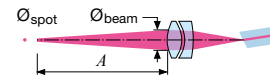
$$\theta = \frac{2\lambda}{\pi \cdot \varnothing_{\text{beam}}} = \frac{\lambda}{\pi \cdot f' \cdot NAe^2}$$

Example:

Wavelength $\lambda = 660 \text{ nm}$
 Focal length $f' = 12 \text{ mm}$
 Numerical aperture $NAe^2 = 0.08$
 Beam diameter $\varnothing_{\text{beam}} = 1.92 \text{ mm}$
 Beam divergence $\theta = 0.22 \text{ mrad}$

Focused Laser Spot

The adjustment of the collimating lens generates a focused beam. At distance A , relative to the fiber collimator, a beam waist with diameter $\varnothing_{\text{spot}}$ is formed.



$$\varnothing_{\text{spot}} = MFD \cdot \left(\frac{A}{f'} - 1 \right)$$

$\varnothing_{\text{spot}}$: Beam diameter in focus
 A : Working distance
 f' : Focal length of collimating lens
 MFD : Mode field diameter of single-mode fiber

The mode field diameter MFD is calculated from the effective numerical aperture NAe^2 at wavelength λ as:

$$MFD = \frac{2 \cdot \lambda}{\pi \cdot NAe^2}$$

Diffraction limits the maximum distance of the focus, where

$$A \leq A_{\text{max}} = f' + \frac{\varnothing_{\text{beam}}^2 \cdot \pi}{8 \cdot \lambda}$$

and $\varnothing_{\text{beam}}$ is the collimated beam diameter.

Transforming a fiber-coupled beam into a spot using a collimator and micro focus optics

Spot Diameter

For a magnification $> 1/10$, a good quality spot can no longer be achieved by simply refocusing the collimation optics. Instead, a combination of collimation and focusing optics is needed. To a good approximation, the micro spot diameter is then given by:

Example:

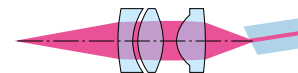
Fiber collimator $f' = 4.5 \text{ mm}$
 Micro focus lens $f' = 11.0 \text{ mm}$
 Mode field \varnothing $MFD = 4.3 \mu\text{m}$
 Spot diameter $\varnothing_{\text{spot}} = 10.5 \mu\text{m}$

$$\varnothing_{\text{spot}} = \frac{f'_{\text{micro focus}}}{f'_{\text{collimator}}} \cdot MFD$$

where MFD is the mode field diameter of the single-mode fiber. Please note that MFD varies with wavelength (for more details, see p. 51)

Optical Scheme

of a fiber collimator with attached micro focus optics.



For single-mode fibers the Gaussian intensity distribution.

Fiber Couplers Selection Criteria

Lens Types for Laser Beam Coupler Type 60SMF and all Fiber Collimators Type 60FC

The coupling lenses provided by Schäfter+Kirchhoff are corrected for spherical aberration and are optimized for the diffraction-limited focusing or collimation. Three different kinds of optics are available:

- Type A (aspheres)
- Type M (laser monochromats or achromat),
- Type RGBV (apochromat)

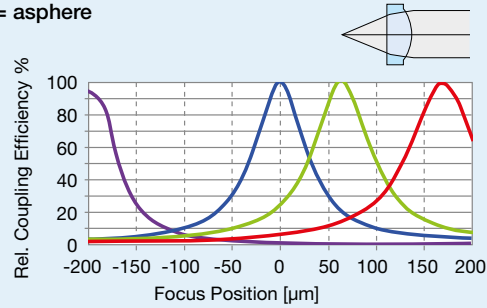
Asphere

Aspheres are designed for single wavelength applications and are corrected for spherical aberration. The focus position varies strongly with wavelength so that the coupler/collimator has to be refocused/recollimated after any changes to the wavelength. The aspheres used are all glass aspheres. This lens type is suitable for UHV applications.

Limited performance as collimators

Due to the manufacturing process of molded aspheres, aspheres used as a collimating lens show a fine structure (concentric rings) or worse in the beam profile. As a result the beam profile is no longer Gaussian. The lens performance as a collimator is limited and alternatives such as monochromats or achromats should be used. However, aspheres can be used as coupling or focus optics without any restriction.

A = asphere

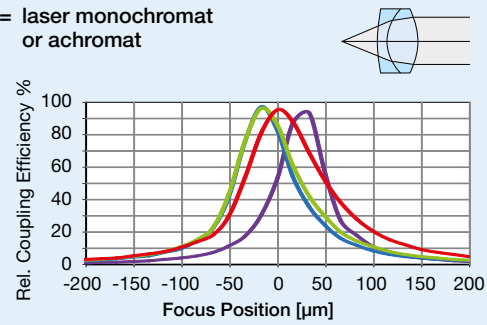


Laser monochromat or achromat

Monochromats are designed for coupling/collimating single wavelengths. They are corrected for spherical aberrations and designed in such a way that it leads to a diffraction-limited beam with an $M^2 < 1.05$. The focus position varies strongly with wavelength so that the coupler/collimator has to be refocused/recollimated after any changes to the wavelength. Monochromats are not suitable for UHV applications. Achromats are designed for coupling/collimating multiple wavelengths. They are additionally corrected for chromatic aberration so that there are certain wavelengths or wavelength ranges where the focal length does not vary significantly and the coupler or collimator does not need to be readjusted. Achromats are not suitable for UHV applications. Both exhibit an undisturbed Gaussian beam profile.

If you have the choice between achromat and monochromat for a monochromatic application, the monochromat should be preferred.

M = laser monochromat or achromat

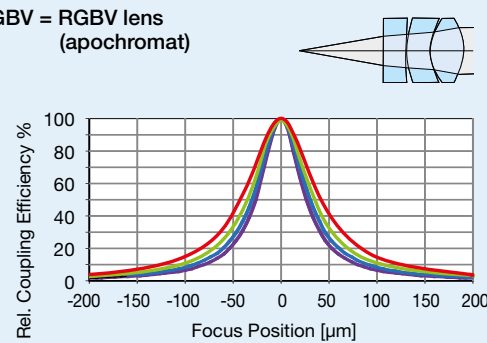


RGBV lens (apochromat)



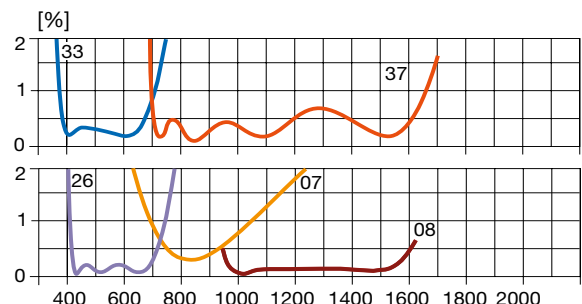
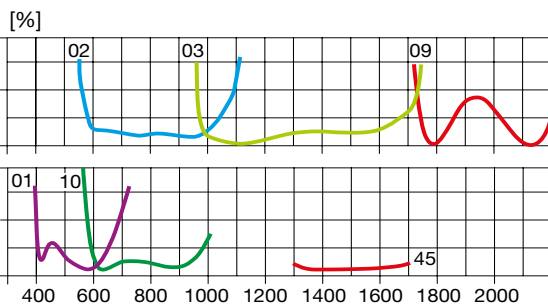
RGBV optics (achromats and even apochromats) are designed for optimum multiple wavelength coupling/collimation by minimizing the chromatic focal shift for all wavelengths from 400 to 660 nm. They are corrected for spherical aberrations and designed in such a way that it leads to a diffraction-limited beam with an $M^2 < 1.05$. A recollimation for wavelengths 400 to 660 nm is not necessary. By minimizing the chromatic focal shift the polychromatic beams are focused at the fiber end-face onto a common point reducing otherwise significant coupling losses. It is not suitable for UHV applications.

RGBV = RGBV lens (apochromat)



Anti-Reflective Coatings (Partial selection only. A coating curve for each product can be downloaded from www.sukhamburg.com)

The lenses in table 1 (page 18) and tables 1–20 (pages 25 – 45) can be ordered with the AR-coatings (selected examples):

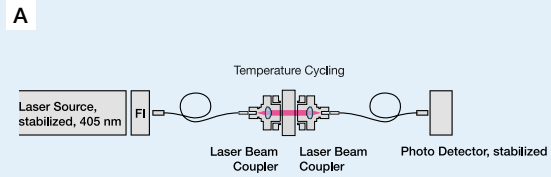


Measurement of Long term Stability of the Laser Beam Coupler

The high stability of fiber-coupling using a laser beam coupler is demonstrated in temperature-stability tests using different focal lengths and wavelengths. The test setup is depicted in Fig. A.

The light emitted by the temperature-stabilized laser diode beam source (with integrated Faraday isolator FI) is guided to the test setup using a polarization-maintaining fiber, collimated by a laser beam coupler, and then coupled back into a polarization-maintaining fiber using a second laser beam coupler, that is placed 12 mm apart.

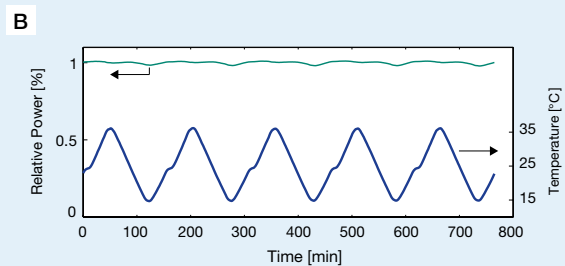
In order to minimize any temperature impact on the measurement equipment, the laser source as well as the photo detector and the data logger are all placed on a thermo-controlled plate at a constant temperature of 25 °C.



Test setup for measuring the stability of two laser beam couplers ($f = 4.5 \text{ mm}$, $\lambda = 405 \text{ nm}$) during successive temperature cycling between 15 °C and 35 °C (A).

The recoupled power is monitored using a photo detector. The coupling setup is placed on a thermo-controlled plate, to vary the temperature between 15 °C and 35 °C in successive cycles with a rate of 0.5 °C per minute. The temperature of the coupling system is monitored by a temperature sensor placed on one of the two laser beam couplers.

Fig B shows the typical results of the relative transmitted power over 5 measurement cycles using a focal length of 4.5 mm and a wavelength of 405 nm. The power is normalized with respect to the maximum power acquired over all measurement cycles. The power deviation from the mean power is $\pm 1.5 \%$.

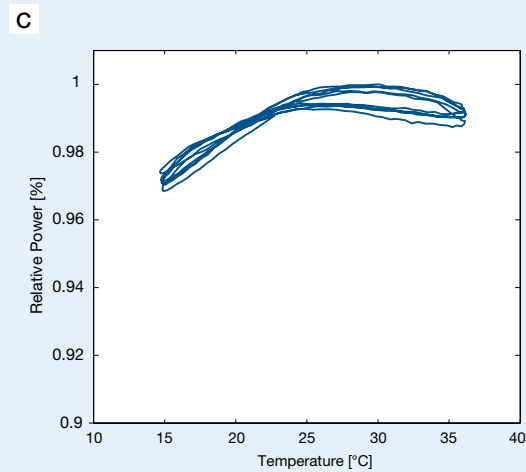


The repetitive pattern in the relative power caused by the temperature cycling is demonstrated more clearly in Fig. C, in which the relative power (normalized to the maximum) is plotted against the temperature of the laser beam couplers.

In this case the maximum coupling efficiency is reached a little above 25 °C and it decreases faster towards lower temperatures than higher temperatures, with the smallest slope near the requested operating point (25 °C).

The respective power curves for each measurement cycle are almost coincident and the power variation at points with equal temperatures is $< 1 \%$, which demonstrates the reproducibility of the pointing stability during temperature cycling and the long-term stability of the fiber-coupling.

The maximum deviation with respect to the maximum power here is 3 %.



How to order using the Product Configurator

1. Using the Product Configurator



Fast and easy selection of fiber couplers and collimators on www.sukhamburg.com

The new product configurator for fiber couplers and collimators, helps select products based on a number of technical specifications and narrows down the search to a few relevant products that meet the customer's need.

- Sliders/check boxes for different parameters like e.g wavelength (range), focal length or input/collimated beam diameter etc.
- Purpose: Coupling only, collimation only or both
- Numerical Aperture: Customer-specific values or selection from suitable fiber cables from Schäfter+Kirchhoff with measurement values
- Integrated calculator of dependent parameters like focal length, collimated beam diameter, Rayleigh range and beam divergence
- Mechanics: Selection of coupler / collimator series
- Selection of lens type (asphere, monochromat, achromat, RGBV, plano convex)
- Special features like UHV compatibility, material and housing options

Technical details can be compared 1:1 by using the product comparison function.

The detailed specific product pages include:

- Detailed description
- Up-to-date technical data, download of data sheets
- Technical drawings including step files (step files for registered users only)
- Adequate accessories including tools, adapters etc.
- Extensive technotes section
- FAQs

Using the product configurator, all coupler parameters can be found on the specific product pages.

The data on the website is updated frequently. If you want the latest information on our fiber couplers and collimators, please refer to www.sukhamburg.com/fiberoptics.html

Example of the Product Configurator (www.sukhamburg.com/products/fiberoptics/configurators/coupler.html)

The screenshot shows the Schäfter+Kirchhoff website's product configurator. The interface includes a navigation bar with 'Home', 'Products', 'Support', 'About S+K', and 'Contact'. The main area is divided into a left sidebar for configuration and a right main area for product selection.

Configuration Sidebar:

- Wavelength/Wavelength range [nm]:** 390 - 670
- Used with fibers of type:** Polarization-maintaining
- Purpose:** View all
- Use a SuK fiber
- Fiber NA:** [input field] **Level:** [dropdown]
- Focal length [mm]:** 1.00 - 200.00
- Beam diameter [mm]:** [input field]
- Beam divergence (collimated side) [mrad]:** [input field]
- Rayleigh range (collimated side) [m]:** [input field]
- Lens Type:**
 - All
 - Asphere
 - Achromat
 - Monochromat
 - RGBV
 - Plano Convex
- Connector Type:** FC-PC
- ADVANCED SETTINGS:**
 - Series:**
 - All
 - 60FC
 - 60FC-T
 - 60FC-A19.5

Main Product Selection Area:

Selected filters: Wavelength: 390 nm - 670 nm, Polarization-maintaining, Monochromat, Connector Type: FC-PC, 60FC, 60FC-SF, Nickel silver/Aluminum

Order Code	Focal length	Lens type	Chromatic correction	Coupling only	AR coating	Beam diameter	Beam divergence	Connector type	Tilt	Outer Ø	Compare
60FC-SF-0-M20-33	20.0 mm	Monochromat			390 - 670 nm			FC-PC		12 mm	<input type="checkbox"/>
60FC-SF-0-M8-33	8.0 mm	Monochromat			390 - 670 nm			FC-PC		12 mm	<input type="checkbox"/>
60FC-SF-0-M5-33	5.0 mm	Monochromat			390 - 670 nm			FC-PC		12 mm	<input type="checkbox"/>
60FC-SF-0-M12-33	12.0 mm	Monochromat			390 - 670 nm			FC-PC		12 mm	<input type="checkbox"/>
60FC-0-M20-33	20.0 mm	Monochromat			390 - 670 nm			FC-PC		12 mm	<input type="checkbox"/>
60FC-0-M12-33	12.0 mm	Monochromat			390 - 670 nm			FC-PC		12 mm	<input type="checkbox"/>
60FC-0-M8-33	8.0 mm	Monochromat			390 - 670 nm			FC-PC		12 mm	<input type="checkbox"/>
60FC-0-M5-33	5.0 mm	Monochromat			390 - 670 nm			FC-PC		12 mm	<input type="checkbox"/>

Main Types of Fiber Couplers Overview (Partial selection only.)

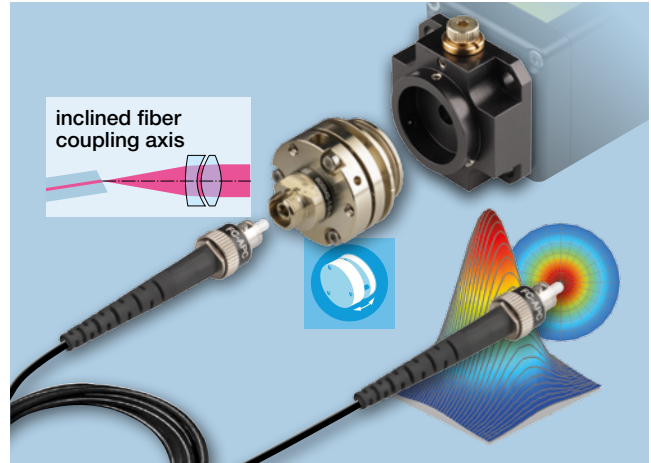
Coupler Type	60SMF Laser Beam Couplers	60FC Fiber Collimators	60FC-SF Fiber Collimators	60FC-L Fiber Collimators	60FC-T Fiber Collimators
Image					
Fiber Coupling	x	used in reverse mode	used in reverse mode	used in reverse mode	used in reverse mode
Fiber Collimation	used in reverse mode	x	x	x	x
Focal lengths	3.1-18 mm	2.7-20 mm	4.5-18 mm	20-200 mm	20-200 mm
Connector Types	FC-PC, FC-APC, LSA (0°,8°-polish), SMA-905 (0°, 5°,8°-polish), Mini-AVIM ®		FC-PC, FC-APC, LSA (0°,8°-polish), SMA-905 (0°, 5°,8°-polish)		
Lens focussing	yes, eccentric key	yes, eccentric key	yes, super-fine thread	yes, eccentric key or shifting the lens tube	yes, eccentric key
Dimensions	Ø 25 mm	Ø 12 mm	Ø 12 mm	Ø ≥ 25/28 mm	Ø ≥ 25/28 mm
Integrated TILT mechanism	x	-	-	-	for alignment of the optical axis with the mechanical axis only
Mounting	system mount Ø 19.5 mm, mounting plate for cage system	e.g. mirror mount	e.g. mirror mount	e.g. mirror mount / clamp collar, mounting plate for cage system	e.g. mirror mount / clamp collar, mounting plate for cage system
Attachable beam shaping optics	-	x	-	x	x
Suitable for UHV	-	x	-	-	-
Available in amagnetic Titanium	x	x	-	-	x
Page	18	25	35	30	30
Other relevant products	60FC-A19.5 with system mount 19.5 mm but w/o tilt mechanism for multimode fiber coupling p. 44	60FC-...-XV with flush connection p. 29 60FC-K compatible with kineMATIX optomechanics p. 42			60FC-Q with integrated quarter-wave plate p. 37 60FC-E- for elliptical beams p. 39 60FC-SMA for SMA-905 high power connector p. 40

Laser Beam Couplers 60SMF with fine thread

for coupling into single-mode or polarization-maintaining fibers

The fiber couplers series 60SMF with fine threaded adjustment screws are an improved, advanced version of the fiber couplers 60SMS. They are high precision fiber couplers optimized for high coupling efficiency, high pointing stability and long-term stability and provide efficient coupling into single-mode and PM fiber cables.

- All appreciated benefits of the well-established 60SMS laser beam coupler including its very high pointing stability and as well as the proven long-term stability.
- Ceramic bearings and adjustment screws with fine thread to ensure an even more precise and easy adjustment.
- For single-mode or PM fiber cables
- System mount Ø 19.5 mm
- Integrated TILT and focusing adjustment
- Focal lengths up to 18 mm
- Choice of aspheres, monochromats, achromats and apochromats, see p. 14
- Various AR coatings for UV - IR
- Choice of fiber receptacles: FC PC or FC APC (standard), many others available
- Copper alloy (standard) or amagnetic titanium



Quick and efficient product selection with the Product Configurator: www.sukhamburg.com



row	curr. no.	1	2	3	4	5	6	7	8	9	10	11	12	13	14	15	16	17	18	19	20	21	22
1	Lens Code	A3.1	M3.1	M4	A4	A4.5S	A4.5	M5	M6.2	A6.2S	A6.2	A7.5	A8	M8	A11	M11	RGBV11	M12	M12NIR	A15	M15	A18	M18
2	Focal length f'	3.1	3.1	4	4	4.5	4.5	5.1	6.2	6.16	6.2	7.5	8	8.1	11	11	11	12	12	15.4	15	18.4	18.4
3	Numerical aperture NA	0.68	0.25	0.25	0.6	0.42	0.5	0.25	0.2	0.3	0.4	0.3	0.3	0.15	0.25	0.23	0.18	0.23	0.23	0.16	0.18	0.15	0.18
4	Clear aperture max. [mm]	5	1.7	2	5	3.7	3.9	2.5	2.5	3.7	3.2	4.5	4.9	2.5	5.5	5	4.0	5.5	5.5	5	5.5	5.5	6.5
5	Correction achromatic		x	x				x	x					x		x	x		x		x		

	Spectral range	Code no. of AR coating																				* IR chalcogenide lens	
6	400 - 600 nm	01	01			01	01					01	01								01	01	
7	600 - 1050 nm	02	02			02	02					02	02								02	02	
8	1050 - 1550 nm	03	03			03	03					03	03								03	03	
9	1300 - 1750 nm	45	45									45	45								45	45	
10	1750 - 2150 nm	09										09	09										
11	390 - 670 nm	33			33																		
12	630 - 1080 nm	10																					10
13	980 - 1600 nm	08																					08
14	420 - 700 nm	26																					26
15	750 - 1550 nm	37																					37
16	400 - 670 nm	51		51																			
17	460 - 740 nm	53																					
18	520 - 830 nm	18																					
19	650 - 1150 nm	07																					
20	450 - 700 nm	04																					
21	1750 - 3000 nm	64																					
22	2500 - 6000 nm	63																					

23	Lens Code	A3.1	M3.1	M4	A4	A4.5S	A4.5	M5	M6.2	A6.2S	A6.2	A7.5	A8	M8	A11	M11	RGBV11	M12	M12NIR	A15	M15	A18	M18	
24	Effective numerical aperture of the fiber NA _e ² (13.5% level)	0.04	0.25	0.25	0.32	0.32	0.36	0.36	0.40	0.50	0.50	0.50	0.60	0.64	0.64	0.88	0.88	0.88	0.96	0.96	1.23	1.20	1.47	1.47
25		0.05	0.31	0.31	0.40	0.40	0.45	0.45	0.50	0.62	0.62	0.62	0.75	0.80	0.80	1.10	1.10	1.10	1.20	1.20	1.54	1.50	1.84	1.84
26		0.06	0.37	0.37	0.48	0.48	0.54	0.54	0.60	0.74	0.74	0.74	0.90	0.96	0.96	1.32	1.32	1.32	1.44	1.44	1.85	1.80	2.21	2.21
27		0.07	0.43	0.43	0.56	0.56	0.63	0.63	0.70	0.87	0.87	0.87	1.05	1.12	1.12	1.54	1.54	1.54	1.68	1.68	2.16	2.10	2.58	2.58
28		0.08	0.50	0.50	0.64	0.64	0.72	0.72	0.80	0.99	0.99	0.99	1.20	1.28	1.28	1.76	1.76	1.76	1.92	1.92	2.46	2.40	2.94	2.94
29	0.09	0.56	0.56	0.72	0.72	0.81	0.81	0.90	1.12	1.12	1.12	1.35	1.44	1.44	1.98	1.98	1.98	2.16	2.16	2.77	2.70	3.31	3.31	

Order Options for Laser Beam Couplers 60SMF

Order Code 60SMF - 1 - 4 - M5 - 33

- 1 = receptacle type FC (standard)
- 4 = inclined coupling axis (8°-polish)
- 0 = coaxial coupling axis (0°-polish)
- 23 = inclined coupling axis (5°-polish), SMA only
- AR coating, see Table 1 row 6ff
- Lens Code (A = asphere / M = monochromat or achromat, RGBV for apochromat) including focal length

Optional:

- LSA = LSA connector (comp. with DIN, AVIO and AVIM)
- SMA = SMA-905 (F-SMA) connector
- MAV = Mini AVIM ® (comp. with midi AVIM ®, Titanium only)

Option:

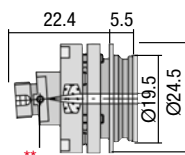
Add **Ti** for titanium construction (amagnetic) – Example:

Order Code 60SMF-1-4-M5-33-Ti

Dimensions

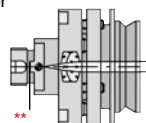
1 Laser beam coupler 60SMF-1-4

with inclined fiber coupling axis for FC-APC connector



2 Laser beam coupler 60SMF-1-0

with inclined fiber coupling axis for FC-PC connector



** Additional grub screw for locking of the fiber ferrule

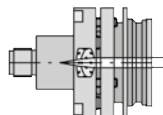
Other Configurations

for the Laser Beam Coupler 60SMF are available on request.

Please contact Schäfter+Kirchhoff.

3 Laser beam coupler 60SMF-SMA-0

with coaxial fiber coupling axis for SMA-905 connector (F-SMA)



Other dimensions on request.

Detailed data sheets, up-to-date technical information, technical drawings including step files, accessories, extensive technotes section and FAQs:

www.sukhamburg.com



Accessories:

Adapters and Tools for Laser Beam Couplers 60SMF (more www.sukhamburg.com)



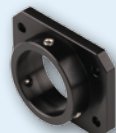
Adapter 19.5 AM25



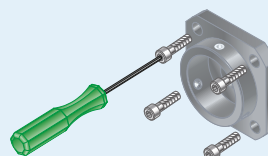
Adapter 19.5 AM25-L



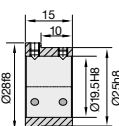
Adapter 60A19.5-F



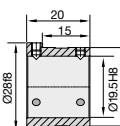
Adapter 60A19.5-F-FB (for fiber bench)



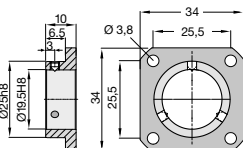
Dimensions



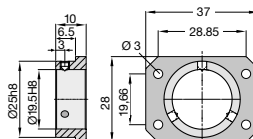
Order Code 19.5 AM25



Order Code 19.5 AM25-L



Order Code 60A19.5-F



Order Code 60A19.5-F-FB

Mounting set for Adapter 60A19.5-F and HeNe laser
4 pcs. screws 4-40 x 3/8" (similar to DIN 912), washers and hex key 3/32
Set is supplied without adapter

Order Code 60A19.5-MS



Adapter 60A19.5-F-AT with integrated attenuator

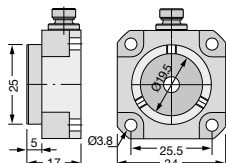


Adapter 60A19.5-F-S with integrated shutter

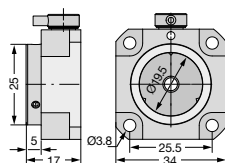


Plate 48MC-MP-19.5
For Ø 19.5 mm components, compatible with the micro-bench system/30mm cage system

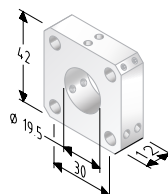
Dimensions



Order Code 60A19.5-F-AT



Order Code 60A19.5-F-S



Order Code 48MC-MP-19.5

Adjustment tools

A Eccentric key Order Code

(p. 18, Table 1: no. 1-16, 60EX-4
no. 17-22) 60EX-5

as an alternative:

B Eccentric key with long handle B

(no. 1-16) 60EX-4-L
(no. 17-22) 60EX-5-L

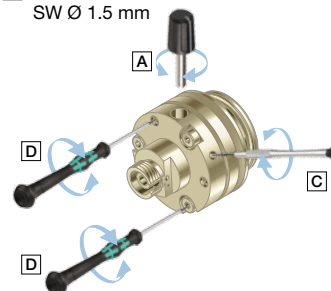


C Screwdriver C

9D-12
Ø 1.2 mm

D Hex screwdriver 50HD-15 D

SW Ø 1.5 mm



Laser Beam Couplers 60SMF Assembly and adjustment

When coupling into single-mode fibers, the laser beam couplers should produce a diffraction-limited spot that matches the mode field diameter and the numerical aperture of the fiber. It is only when this condition is met that fiber coupling with high coupling efficiencies of up to 85% are achieved.

The precision adjustment mechanism is used for the precise lateral alignment of the mode field of the fiber to the focused laser spot in order to achieve maximum overlap. For polarization-maintaining fibers, the polarization axis of the fiber additionally needs to be aligned with the polarization axis of the incoming radiation.

The adjustment is done in four steps:

1. Center the laser beam coupler with the laser beam propagation axis **[B]** by using the adapter 60A19.5-F (or similar).
2. Move the mode field of the fiber laterally for maximum overlap with the laser spot using the tilt adjustment **[F]**.
3. Adjust the pre-adjustment of the focus setting **[H]** (only needed if the wavelength is different than specified).
4. Rotate the laser beam coupler to align the polarization axes (only for PM-fibers) **[L]**.

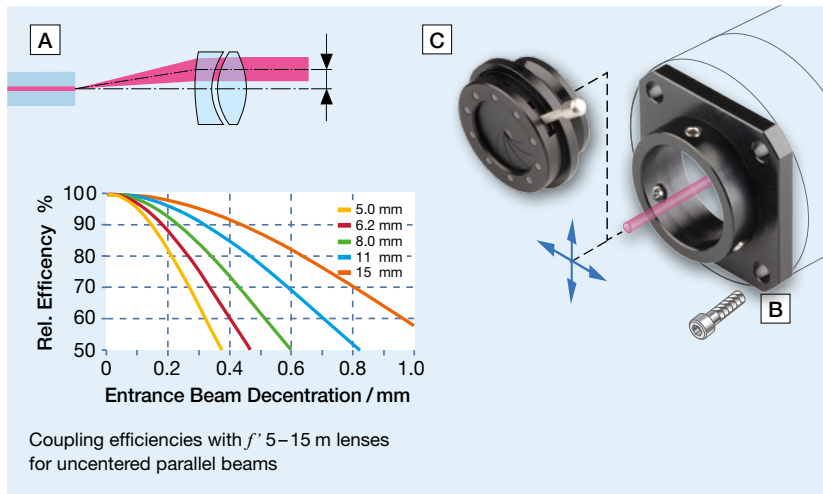
1. Centering of laser beam coupler with the propagation axis

A beam displaced laterally from the optical axis causes it to be focused onto the fiber center, but with inclined propagation in relation to the fiber optical axis and parts of the beam exceed the acceptance angle of the fiber **[A]**.

The inclined propagation causes lens aberrations such as coma and astigmatism to appear. These are removed by centering the axes of the laser beam and the coupling optics using e.g. adapter 60A19.5-F, **[B]**.

The laser beam coupler is simply replaced by an aperture (e.g. 13BL1-13) **[C]**. The aperture diameter should be similar to the $1/e^2$ -level of the laser beam. This allows the transmitted power to be maximized by adjusting the adapter position concentrically (using the deliberately oversized mounting holes) while measuring the laser power.

Only a coarse alignment is necessary, and this can be done by hand, as the positioning accuracy must only be within 7 - 10 % of the beam diameter.



2. Lateral adjustment of the mode field and laser spot

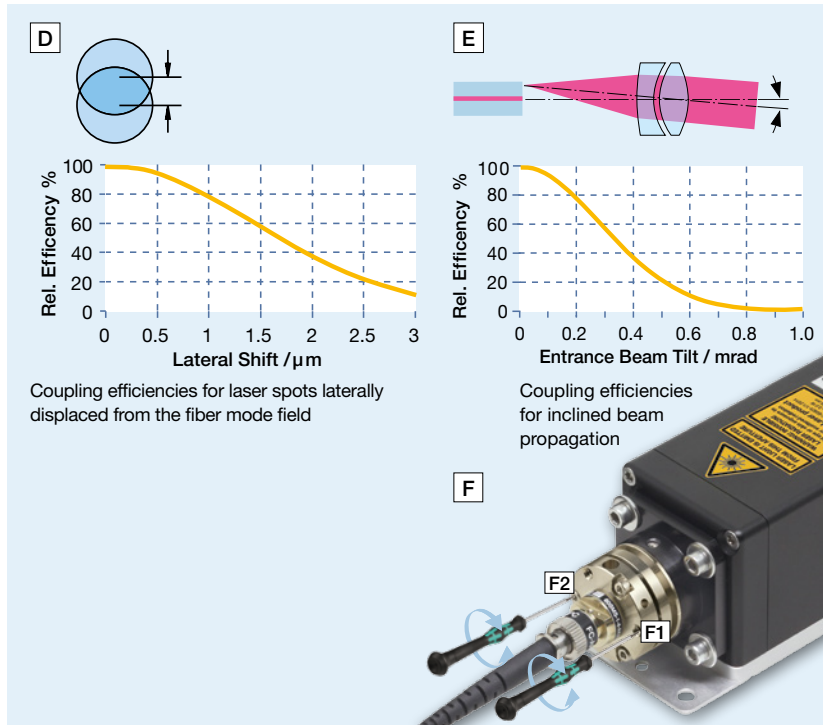
Lateral displacement of the laser beam focus away from the mode field of the fiber arises because of:

- Production tolerances in the centering of the coupling lens and/or the centering of the fiber core in the fiber ferrule. With a mode field or spot diameter of 2–5 μm , the required precision is in the submicron range **[D]**,
- Inclined beam propagation **[E]**.

Example: When using a 5 mm focal length lens, a beam inclined by 1 mrad results in a lateral offset of 5 μm , completely missing the mode field and resulting in a very low coupling efficiency.

By using the tilt mechanism **[F]** of the laser beam coupler, the mode field of the fiber is adjusted laterally to achieve overlap with the laser focus spot.

The adjustment screws **[F1]** are turned systematically (using screwdriver 50HD-15) one after the other (e.g. in a clockwise direction), so that the signal is maximized. Now the procedure is repeated for the three locking screws **[F2]** until all are fully tightened.



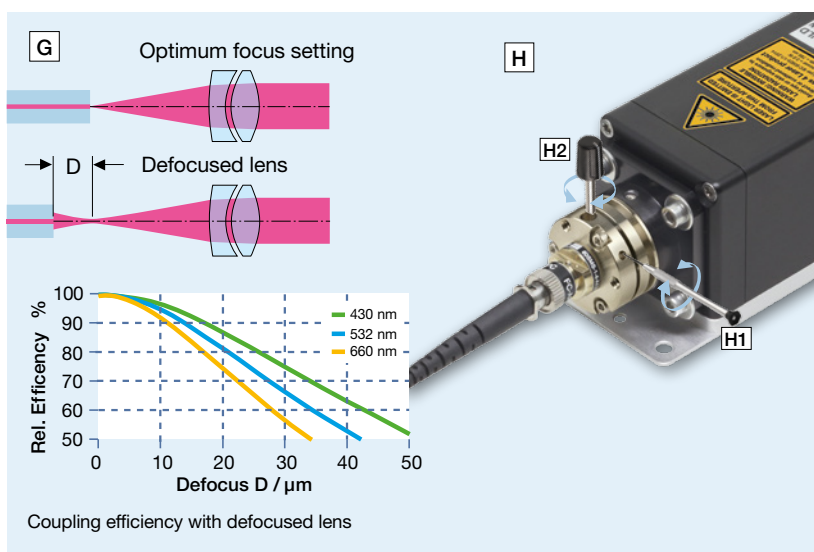
Laser Beam Coupler 60SMF Assembly and adjustment

3. Refocusing

Schäfter + Kirchhoff laser beam couplers are supplied pre-adjusted for the specified wavelength and refocusing is not necessary for a properly collimated laser beam.

The positioning accuracy of the laser focus in the coaxial direction is less critical than for the lateral directions. Because of the small depth of focus (Rayleigh range) of the laser spot, however, a decrease in coupling efficiency occurs even with a defocus of only a few microns [G].

Refocusing [H] can be done by releasing the two lens-locking screws (accessible via small holes) using screwdriver 9D-12 [H1]. The focus setting is readjusted using the eccentric key 60EX-4/60EX-5 [H2], before retightening the locking screws.

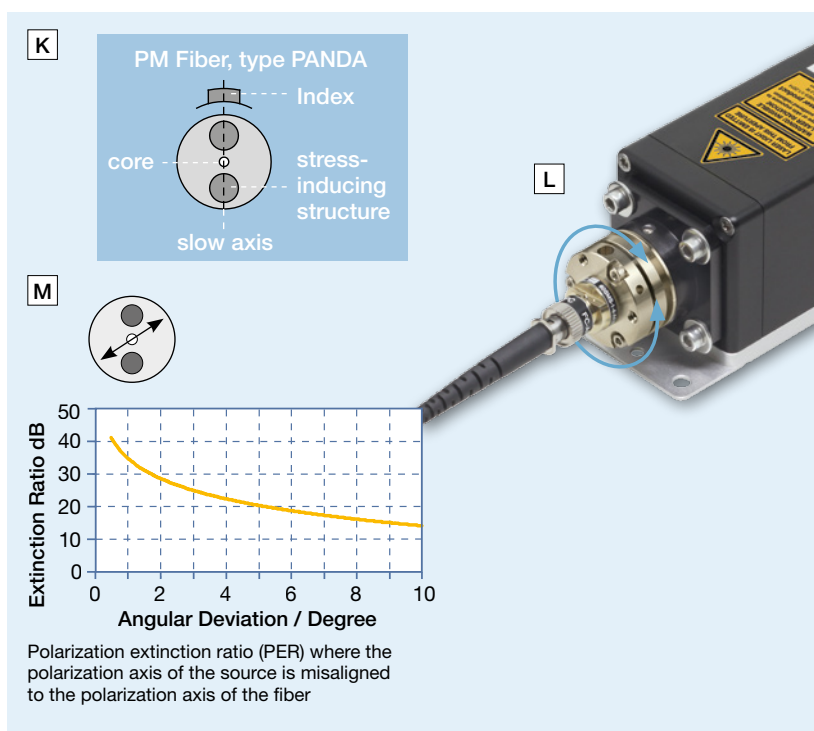


4. Alignment of the polarization axis

Polarization-maintaining single-mode fibers [K] guide radiation in two principle states of polarization (the fast and slow axis). The linear polarization of light coupled into one of the axes is maintained. If light is guided partly in the other axis, then the outcome polarization is elliptical (if the coherence length of the source is larger than the phase difference). Strain and temperature variations, however, change this arbitrary elliptical state.

A linear and stable state of polarization is obtained by rotating the laser beam coupler [L], to adjust the axes. This is done precisely with the help of the SK010PA polarization analyzer. The analyzer evaluates the polarization extinction ratio and immediately displays the results of any adjustments made to the polarization axis.

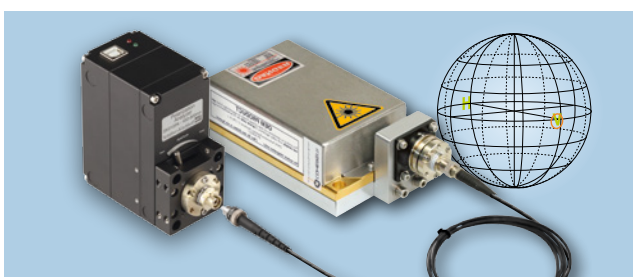
The polarization extinction ratio PER, the ratio between the powers guided in the two polarization axes, serves as a decisive measure of the fiber alignment. The effect of an angular deviation between the laser and fiber polarization axes is shown in [M].



Related Product: Polarization Analyzer SK010PA

for precise coupling of linearly polarized light into polarization-maintaining fibers.

For details see page 65.



60SMF Fiber Coupling Sets

for laser diode modules and DPSS modules using the the 60SMF laser beam coupler

Schäfter+Kirchhoff offer fiber coupling sets for laser diode modules and DPSS laser modules from various manufacturers.

The fiber coupling sets are based on the 60SMF laser beam coupler and a PMC fiber cable. A large variety of adapters and accessories such as fiber collimators and micro-focus optics are available

Schäfter+Kirchhoff offer the service of performing the assembling and alignment of these lasers

Example: Fiber coupling set for Oxxius LaserBoxx* LBX and LCX

Laser Module: Single-mode and polarization-maintaining

- Coupling efficiency >70 %
- Wavelengths: 375 nm - 785 nm
- Polarization extinction ratio ≥ 26 dB
- Vibration insensitive, persistently stable
- Long-term stability
- Reliable coupling

- 1 Oxxius Laser Boxx module
- 2 Laser beam coupler 60SMF
- 3 Polarization-maintaining fiber cable PMC
- 4 Fiber Collimator 60FC (option)
- 5 Micro focus optics 5M (option)

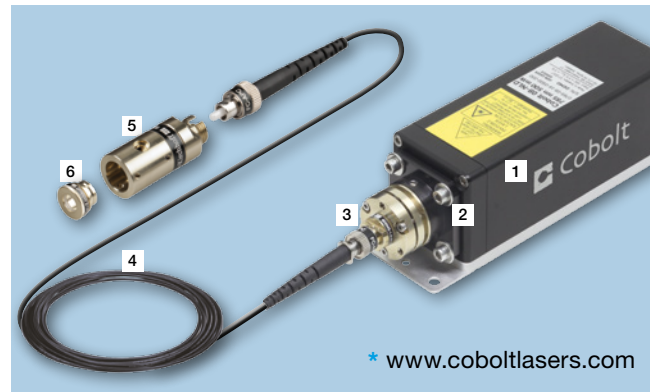


Example: Fiber coupling set for Cobolt* 08-01 Series

Laser Module: Single-mode and polarization-maintaining

- Coupling efficiency >70 %
- Wavelengths: 405 nm - 1074 nm
- Polarization extinction ratio ≥ 26 dB
- Vibration insensitive, persistently stable
- Long-term stability
- Reliable coupling

- 1 Cobolt 08-01 series laser module
- 2 Adapter type 60A19.5-F
- 3 Laser beam coupler 60SMF
- 4 Polarization-maintaining fiber PMC
- 5 Fiber Collimator 60FC (option)
- 6 Micro focus optics 5M (option)

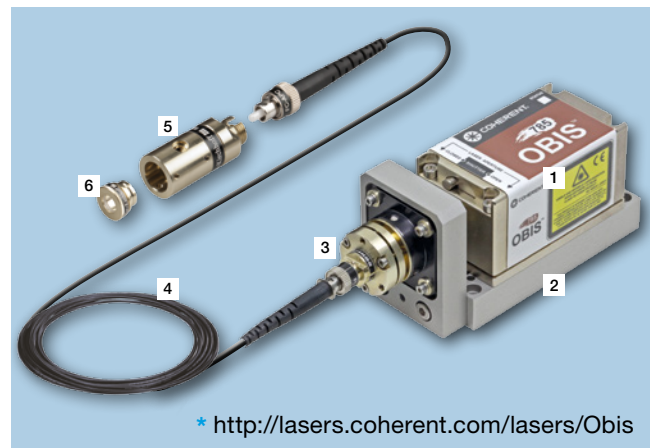


Example: Fiber coupling of an Coherent OBIS* LX/LS laser module

Laser Module: Single-mode and polarization-maintaining

- Coupling efficiency >70 %
- Wavelengths: 372 nm - 980 nm
- Polarization extinction ratio ≥ 26 dB
- Vibration insensitive, persistently stable
- Long-term stability
- Reliable coupling

- 1 OBIS LX/LS series laser module
- 2 Mounting console 48MP-OBIS
- 3 Laser beam coupler 60SMF
- 4 Polarization-maintaining fiber PMC
- 5 Fiber Collimator 60FC (option)
- 6 Micro focus optics 5M (option)



Fiber-Fiber Couplers 60FF, 60FF-T, 60FF-P

for interconnecting two single-mode fibers or polarization-maintaining fibers

The 60FF fiber-fiber couplers are used for interconnecting two fiber cables. They can be aligned and focused so that fiber cables with non-core centered connectors can be coupled with a low coupling loss and, additionally, the polarization axes can be aligned.

The 60FF fiber-fiber couplers are based on two 60SMF laser beam coupler. They can be used with two differing coupling focal length and/or connection types in order to interconnect different types of fibers and/or cables with differing connector types.

60FF fiber-fiber couplers are available with optics for wavelengths in the range 370–2300 nm.

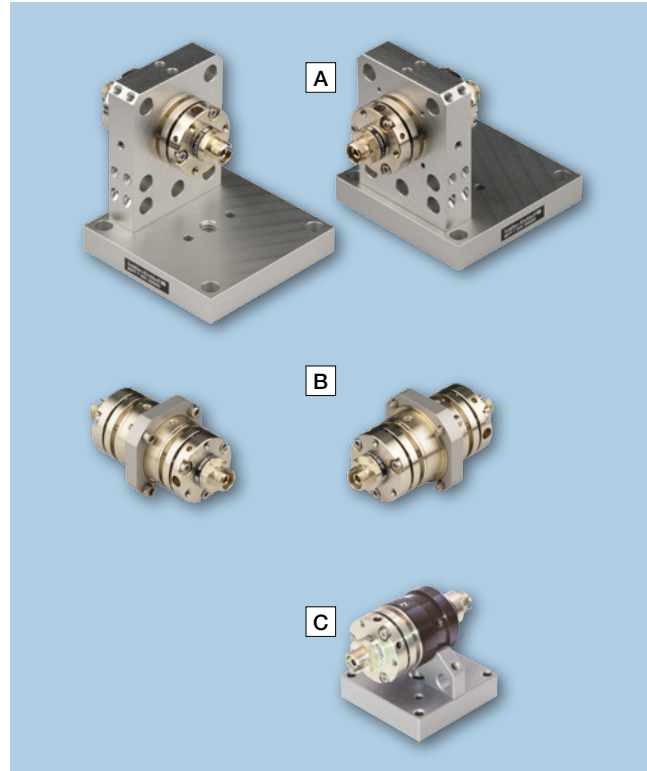
The 60FF-T fiber-fiber coupler **A** is a desktop version. It is compatible to the multicube system.

Optionally, a system can be expanded using a limitless combination of multicube™ optics and flanges, e.g. a polarizer or retardation optics.

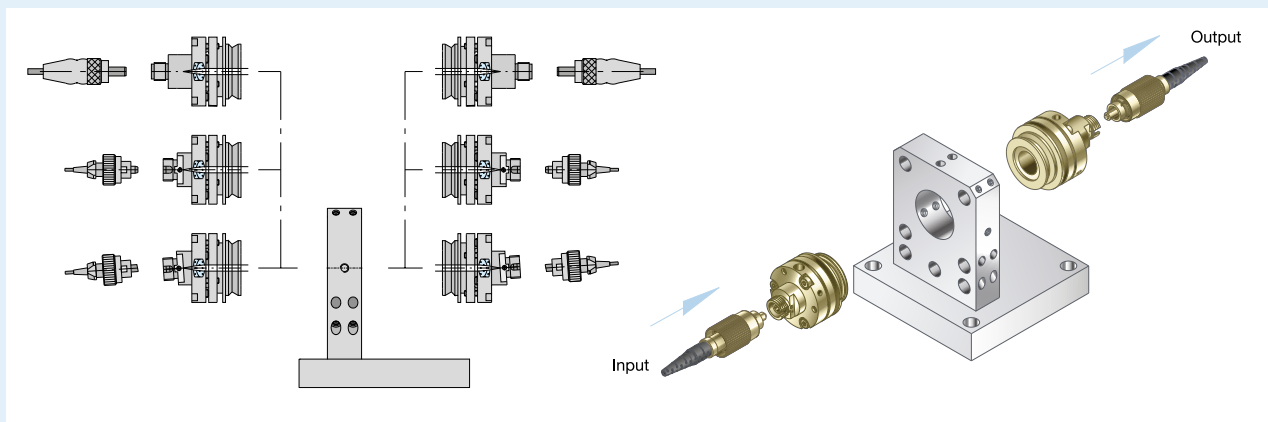
For extending the fiber-fiber coupler, a second mounting plate and four rods are included.

The 60FF-P fiber-fiber coupler **B** is designed for panel mount.

There is a simplified version, the 60FF fiber-fiber coupler used for multimode applications **C**. It is based on one 60SMF laser beam coupler and one 60FC fiber collimator.



Configurations



How to order

1. Choose the mechanics type **A**, **B**, or **C** you need (**C** for multimode applications only)
2. Select the 60SMF laser beam couplers for out- and for in-coupling in terms of focal length, wavelengths range and connector type, see p. 18.
We recommend a focal length of 11 / 12 mm.

Adjustment tools for the 60SMF laser beam couplers, see p. 19.

Order options for 60FF-x fiber-fiber couplers single-mode and polarization-maintaining

Order Code 60FF - T - 60SMF - ... - 60SMF - ...

- Laser beam couplers type 60SMF for out and for in coupling, see p. 18
- Mount type T multicube compatible P flange mount

Order options for 60FF fiber-fiber couplers multimode

Order Code 60FF - 60SME - ... - 60FC - ...

- Fiber collimator type 60FC for in-coupling see p. 25
- Laser beam coupler type 60SMF for out-coupling see p. 18

Fiber Collimators 60FC

for collimating radiation exiting from an optical fiber or for coupling a beam into an optical fiber

- Focal lengths up to 20 mm (for longer focal lengths see p. 30)
- Choice of aspheres*, monochromats, achromats and apochromats, see p. 14
- Various AR coatings for UV - IR
- Choice of fiber receptacles: FC PC or FC APC (standard), many others available
- Focussing of the optics using an eccentric key
- Compact Ø 12 mm housing
- Front connector accepts attachment optics
- Correction - achrom.
- Copper alloy (standard) or amagnetic titanium



Fiber Couplers: Incouplers and Collimators

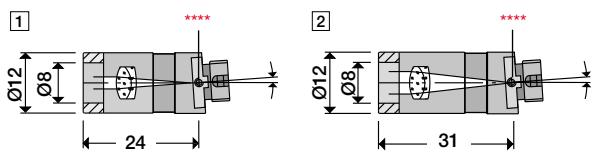
Table 1 Optics options for Fiber Collimator Type 60FC (Partial selection only. More on www.sukhamburg.com)

row	curr. no	1	2	3	4	5	6	7	8	9	10	11	12	13	14	15	16	17	18	19	20	21	22	23
1	Lens Code	A2.7	A3.1	M3.1	M4	A4	A4.5S	A4.5	M5	A6.2S	A6.2	M6.2	A7.5	A8	M8	A11	M11	RGBV11	M12	M12NIR	A15	M15	A18	M20
2	Focal length f'	2.75	3.1	3.1	4	4	4.5	4.5	5.1	6.2	6.2	6.2	7.5	8	8.1	11	11	11	12	12	15.4	15	18.4	20
3	Numerical aperture NA	0.55	0.68	0.25	0.25	0.6	0.42	0.5	0.25	0.3	0.4	0.18	0.3	0.3	0.15	0.25	0.23	0.18	0.23	0.23	0.16	0.18	0.15	0.16
4	Clear apert. max. [mm]	3.6	5	1.7	2	5	3.7	3.9	2.5	3.7	3.2	2.2	4.5	4.9	2.5	5.5	5	4	5.5	5.5	5	5.5	5.5	6.5
5	Coll. beam [mm]**	0.49	0.56	0.56	0.72	0.72	0.81	0.81	0.90	1.12	1.12	1.12	1.35	1.44	1.44	1.98	1.98	1.98	2.16	2.16	2.77	2.7	3.31	3.61
6	Beam diverg. [mrad]**	0.86	0.77	0.77	0.59	0.59	0.53	0.53	0.47	0.39	0.39	0.39	0.32	0.3	0.29	0.22	0.22	0.22	0.2	0.2	0.15	0.16	0.13	0.12
7	Correction - achrom.			x	x				x						x			x			x			
8	Coupling/MM only*	x	x			x	x			x				x			x				x		x	
Spectral range		Code no. of AR coating																						
		* Coupling / multimode collimation only ** Calculated for NAe ² = 0.09 and λ = 670 nm ***IR chalcogenide lens																						
9	350 - 460 nm	52	52																					
10	400 - 600 nm	01	01	01		01	01			01			01			01					01		01	
11	600 - 1050 nm	02	02	02		02	02			02			02			02					02		02	
12	1050 - 1550 nm	03	03	03		03	03			03			03			03					03		03	
13	1300 - 1750 nm	45	45	45			45			45			45			45					45		45	
14	1750 - 2150 nm	09					09			09			09											
15	390 - 670 nm	33			33				33		33				33				33					33
16	630 - 980 nm	10							10						10				10		10			10
17	980 - 1550 nm	08							08						08				08					08
18	420 - 700 nm	26																				26		
19	750 - 1550 nm	37																				37		
20	400 - 670 nm	51		51														47						
21	520 - 830 nm	18															18							
22	650 - 1150 nm	07						07			07		07											
23	1750 - 3000 nm	64					64***																	
24	2500 - 6000 nm	63					63***																	
25	for UH vacuum	x	x			x	x			x		x	x			x					x		x	
26	Dimensions	1	1	1	1	1	1		1	1	1	1	1	1	1	1	1	1	1	2	1	1	2	2

Table 1.1 Beam diameter as a function of the working distance A. (Calculated for NAe² = 0.09 and λ = 670 nm)

Collimated	Lens type	A2.7	A3	M3.1	M4	A4	A4.5S	A4.5S	M5	A6.2S	A6.2	M6.2	A7.5	A8	M8	A11	M11	RGBV11	M12	M12NIR	A15	M15	A18	M20	
	Focal length f'	2.75	3.1	3.1	4	4	4.5	4.5	5.1	6.2	6.2	6.2	7.5	8	8.1	11	11	11	12	12	15.4	15	18.4	20	
29	0.5 m	1.00	0.95	0.95	0.93	0.93	0.97	0.97	1.03	1.17	1.17	1.17	1.38	1.47	1.48	2.0	2.0	2.0	2.2	2.2	2.7	2.8	2.7	3.3	3.6
30	1.0 m	1.80	1.63	1.63	1.39	1.39	1.33	1.33	1.31	1.35	1.35	1.35	1.49	1.55	1.6	2.0	2.0	2.0	2.2	2.2	2.7	2.8	2.7	3.3	3.6
31	5.0 m	8.6	7.7	7.7	6.0	6.0	5.3	5.3	4.7	4.0	4.0	4.0	3.4	3.3	3.3	2.9	2.9	2.9	2.9	3.1	3.2	3.1	3.5	3.8	
32	10.0 m																								

Dimensions

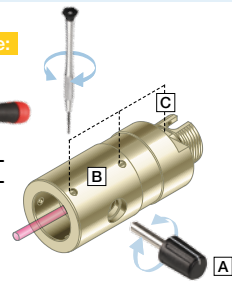


**** Additional grub screw for locking of the fiber ferrule (FC and LSA only)

Adapters for mirror mounts Ø 25 mm, Ø 25.4 mm, and with system mount Ø 19.5 mm, see page 27.

Assembly and Adjustment Tools

- A** Focusing of the collimator
Tool: Eccentric key
no. 1-17 60EX-4
no. 18-23 60EX-5
or as an alternative:
Tool: Eccentric key with long handle
no. 1-17 60EX-4-L
no. 18-23 60EX-5-L
- B** Locking of focus position
Tool: Screwdriver 9D-12
- C** Locking of fiber ferrule with grub screw
Tool: Screwdriver 9D-12



Order Options for fiber collimators type 60FC

- Order Code** 60FC-4-M5-33
- AR coating (see Table 1, row 9ff)
 - Lens Code (A = asphere / M = monochromat or achromat) including focal length
 - Fiber receptacle: 4 = FC-APC connection (8°-polish)
0 = FC-PC connection (0°-polish)

Material Option:

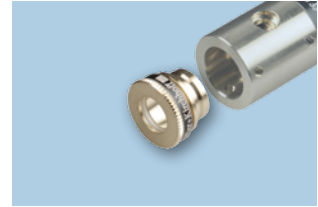
- Add T for titanium housing (amagnetic):
Example **Order Code** : 60FC-4-M5-33-Ti
- Optional:**
LSA = LSA conn. (comp. with DIN, AVIO and AVIM)
SMA = SMA-905 connector (F-SMA)
MAV = Mini AVIM ® (Titanium only)

Attachment optics: Micro Focus Optics Type 5M

Micro focus optics used for focussing the collimated radiation of a fiber collimator

- Attachment optics for fiber collimators type 60FC with outer diameter Ø 12 mm (p. 25)
- Choice of aspheres, achromats or singlet lenses
- Various optics for UV - IR
- Amagnetic housing made from Titanium on request

Detailed data sheets and up-to-date technical information: www.sukhamburg.com



row	curr. no	1	2	3	4	5	6	7	8	9	10	11	12	13	14	15	16	17	18	19	
1	Lens Code	A4	A4	A4.5	A6.2	A8	A11	A15	A18	M12	M20	M25	M30	M40	M50	M60	S50	S88	S150	S325	
2	Focal length f'	4	4	4.5	6.2	8	11	15	18	12	20	25	30	40	50	60	50	88	150	325	
3	Num. aperture NA	0.58	0.56	0.55	0.4	0.5	0.25	0.16	0.15	0.21	0.13	0.11	0.09	0.06	0.05	0.05	0.05	0.03	0.018	0.009	
4	Clear aperture max. [mm]	4.6	5	5	5	5	5	5	5	5	5	5	5	5	5	5	5	5	5	5	
Spectral range																					
5	650 - 1150 nm	07		07	07	07															
6	400 - 600 nm	01	01		01	01	01	01	01												
7	600 - 1050 nm	02	02		02	02	02	02	02												
8	1050 - 1550 nm	03	03		03	03	03	03	03												
9	1300 - 1750 nm	45			45			45	45												
10	1750 - 2150 nm	09			09	09															
11	390 - 670 nm	33								33	33						33	33	33	33	
12	630 - 980 nm	10/05								10	10						05	05	05	05	
13	980 - 1550 nm	08								08	08						08	08	08	08	
14	420 - 700 nm	26										26	26	26	26	26					
15	750 - 1550 nm	37										37	37	37							
16	1750 - 3000 nm	64			64**																
17	2500 - 6000 nm	63			63**																
18	Dimensional drawings	1	1	1	1	1	1	1	1	1	1	1	1	1	1	1	1	1	1	1	
19	Length B [mm]	4.6	4.6	4.5	4.5	4.5	4.5	4.5	4.5	4.5	4.8	4.4	4.5	4.5	4.4	4.5	4.9	4.9	4.9	4.9	
20	Work. distance A	2.2	2.2	2.37	3	5.4	7.4	13.4	16.5	9.9	17.9	22.8	26.7	36.7	48.2	58	48.7	82.4	149	320	
21	Suitable for UH vacuum	x	x	x	x	x	x	x	x								x	x	x	x	

Transforming a fiber-coupled beam into a spot using a collimator and micro focus optics

Spot Diameter

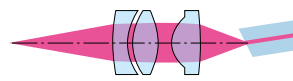
For a magnification > 1/10, a good quality spot can no longer be achieved by simply refocusing the collimation optics. Instead, a combination of collimation and focusing optics is needed. To a good approximation, the micro spot diameter is then given by:

$$\varnothing_{spot} \approx \frac{f'_{micro\ focus}}{f'_{fiber\ collimator}} MFD$$

where MFD is the mode field diameter of the single-mode fiber. Please note that MFD varies with wavelengths (for more details, see p. 48)

Optical Scheme

of a fiber collimator with attached micro focus optics.



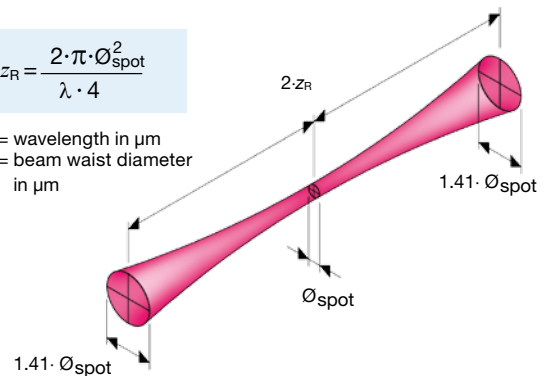
For single-mode fibers the Gaussian intensity distribution and beam shape are maintained.

Rayleigh range

For a Gaussian beam, the depth of focus is defined by the Rayleigh range $2 \cdot z_R$ in which the beam waist diameter does not increase more than a factor of 1.41

$$2 \cdot z_R = \frac{2 \cdot \pi \cdot \varnothing_{spot}^2}{\lambda \cdot 4}$$

λ = wavelength in μm
 \varnothing_{spot} = beam waist diameter in μm



Order Options for Micro Focus Optics Type 5M

Order Code 5M - M60-26-S

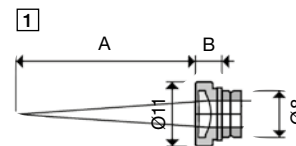
- AR coating (see Table 2, row 5 ff)
- Lens Code (A = asphere / M = monochromat or achromat / S = singlet), including focal length

Material Option:

Add T for titanium housing (amagnetic):

Example: **Order Code** 5M - M60-26-S-T

Dimensions



Attachment optics: Polarization Filters Type 5PF

Transforms an arbitrarily polarized beam into a linearly polarized beam

- Polarization filters with system mount \varnothing 8 mm for attaching to fiber collimators series 60FC (with outer diameter \varnothing 12 mm) (p. 23)
- Free rotation for best adjustment with positional locking using radially arranged screws.
- Polarization extinction ratio 10.000:1
- Surface deviation $< \lambda/4$
- Wavelength range UV - IR
- Broadband AR Coating
- Optional long-form housing -L ([2] and [4]) with system mount \varnothing 8 mm for adding additional attachment optics



There are two series:

- Polarization beam splitter cubes 5PF-C with deflection of the unwanted orthogonally polarized radiation
- Dichroic polarization filter. 5PF-P The filter is laminated to a glass substrate with an 1.5° inclined mounting in order to avoid direct back-reflections

Table 3 Polarization Filter Type 5PF (Partial selection only. More on www.sukhamburg.com)

Row	Series	Polarizer type	Spectral range	Extinction	Transmission (%)	Clear aperture (mm)	Polarization filter (short) Order Code	Dimensions	Polarization filter (long) Order Code	Dimensions
1	5PF-P		600 - 850	10 ⁴ :1	>84-93	5	5PF-P - 600-S	[1]	5PF-P - 600-L	[2]
2			750 - 1250	10 ⁴ :1	>87-93	5	5PF-P - 750-S		5PF-P - 750-L	
3			1280 - 1500	10 ⁴ :1	>96-98	5	5PF-P-1300-S		5PF-P-1300-L	
4	5PF-C		390 - 480	10 ⁴ :1	>95	4	5PF-C - 400-S	[3]	5PF-C - 400-L	[4]
5			450 - 700	10 ⁴ :1	>95	4	5PF-C - 450-S		5PF-C - 450-L	
6			750 - 1100	10 ⁴ :1	>95	4	5PF-C - 750-S		5PF-C - 750-L	
7			1100 - 1700	10 ⁴ :1	>98	4	5PF-C-1100-S		5PF-C-1100-L	

Dimensions

Dichroic glass polarizers type 5PF-P

* With front connector for additional attachment optics

Polarizing beam-splitter cubes type 5PF-C

* With front connector for additional attachment optics

Attachment optics: Retardation Optics 5WP

Transforms linearly polarized radiation into circularly polarized radiation

- Attachment optics for fiber collimators type 60FC with outer diameter \varnothing 12 mm (p. 23)
- Low-order quarter-wave optics (zero-order and dichroic optics on request)
- For various wavelengths UV-IR
- Free rotation for best adjustment with positional locking using radially arranged screws
- Adjustable using Schäfter+Kirchhoff Polarization Analyzer Series SK010PA (p. 63)
- For fiber collimators with $f' > 20$ mm: see page 35 for collimators of type 60FC-Q with integrated retardation optics.

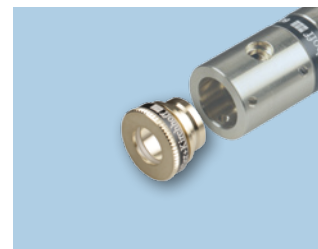


Table 4 Retardation Optics 5 WP

row	Series	curr. no	1	2
1	5WP-P	Retardation	$\lambda/4$	$\lambda/4$
2		Order	L = low	L = low
3		Wavelength [nm]	Tab. 5	Tab. 5
4		Clear aperture max. [mm]	5	5
5		Design	S	L*
6		Dimens. drawing	[5]	[6]

Table 5 Typical wavelengths

Element	λ [nm]	Element	λ [nm]	Element	λ [nm]
Helium	He 389	Lithium	Li 671	Ruby	Rb 780
Strontium	Sr 461	Strontium	Sr 689	Krypton	Kr 811
Ytterbium	Yb 556	Sodium	Na 760	Caesium	Cs 852
Sodium	Na 589	Potassium	K 767	Helium	He 1083

Partial selection only. More on www.sukhamburg.com.

Dimensions

Quarter-wave plates type 5WP

* With front connector for additional attachment optics

Order Options for Retardation Optics Type 5WP

Order Code 5WP - 4 - 780 L - S

- Design: S: short, L: long
- Retardation: L: low order, Z: zero order
- Wavelength [nm], see Table 5
- Retardation: 4 for $\lambda/4$

Attachment Optics: Iris Diaphragms Type 5BL and Pinholes Type 5H

Iris diaphragms and pinholes are used to reduce the diameter of a collimated beam.

- Attachment optics for fiber collimators type 60FC with outer diameter \varnothing 12 mm (p. 23)
- Iris diaphragm with variable aperture, pinholes with fixed aperture
- Please note: In case of use with a single-mode/PM-fiber, the Gaussian beam from the fiber collimator is truncated by the iris diaphragm/pinhole

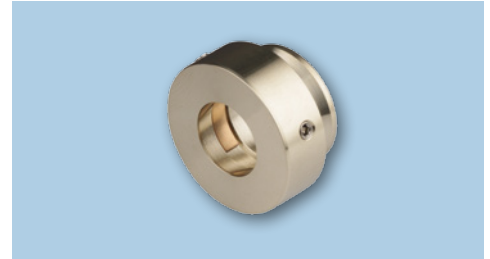


row	Series	\varnothing min - max [mm]	Order Code	
1	5BL	0.8 - 5	5BL0.8-5	Partial selection only. More on www.sukhamburg.com
2	5H	0.5	5H-0.5	
3	5H	0.8	5H-0.8	
4	5H	1.0	5H-1.0	
5	5H	2.0	5H2.0	

Accessories: Adapters for Fiber Collimators of Type 60FC / 60FC-SF

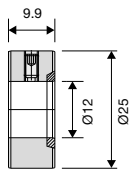
Suitable for fiber collimators type 60FC and 60FC-SF with diameter \varnothing 12 mm

- Adapters to outer \varnothing 25 mm, \varnothing 1" (25.4 mm) e.g. for use with standard mirror mounts or with system mount \varnothing 19.5 mm.
- Adapter type 12AM-19.5: Ideal for incorporation in a microbench / cage system, with mounting brackets and the construction kit multicube™ from Schäfter+Kirchhoff.

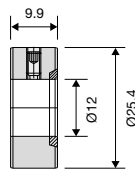


Dimensions Adapter Types

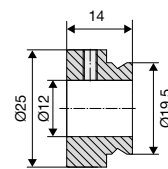
1 Type 12C-AM25



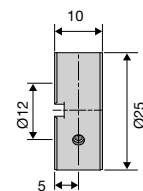
2 Type 12AM25.4



3 Type 12AM-19.5



4 Type 12AM25-M4



Order Options for the Adapters

1 Order-Code 12C-AM25
for outer \varnothing 25 mm

2 Order-Code 12AM25.4
outer \varnothing 25.4 mm

3 Order-Code 12AM-19.5
with system mount
 \varnothing 19.5 mm

4 Order-Code 12AM25-M4
with M4 thread for
post-mount

Accessories: Holder for Fiber Collimators Type 60FC

Suitable holder for fiber collimators from type 60FC and 60FC-SF:

- MDI-HS-2-3012T by Radiant Dyes.
- For details and enquiries: www.radiant-dyes.com



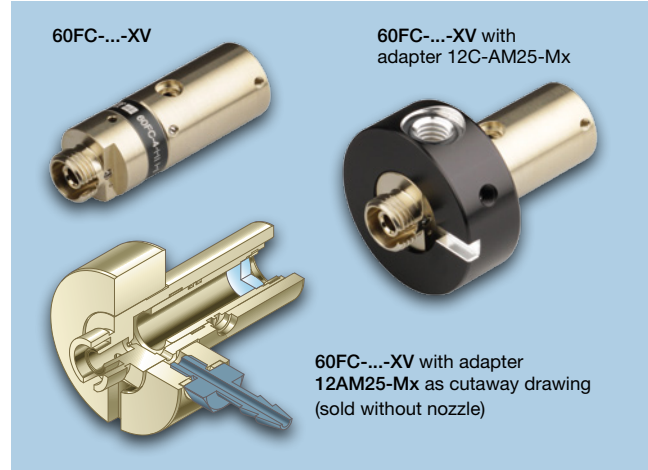
Fiber Couplers 60FC-...-XV for flushing

Special version of the series 60FC fiber collimators with bore hole for flushing purposes

Available with lenses for the UV wavelength range.
(Reference: Marciniak et al., arXiv:1704.05879)

- Focal lengths up to 24 mm
- Plano-convex lenses only diffraction-limited for fibers with effective $NA_e^2 < 0.04$
- AR coated
- Choice of fiber receptacles: FC PC or FC APC (standard)
- Focussing of the optics using eccentric key
- Compact \varnothing 12 mm housing
- Copper alloy

There are special adapter rings 12AM25-Mx with M3, M4 or M5 flush nozzle with outer diameter \varnothing 25 mm e.g. for use with a standard kinematic mirror mount or with system mount \varnothing 19.5 mm with a bore hole matching the bore hole of the fiber collimator. A thread allows connecting of a flush nozzle.



Detailed data sheets, up-to-date technical information, technical drawings including step files, accessories, extensive technotes section and FAQs:
www.sukhamburg.com

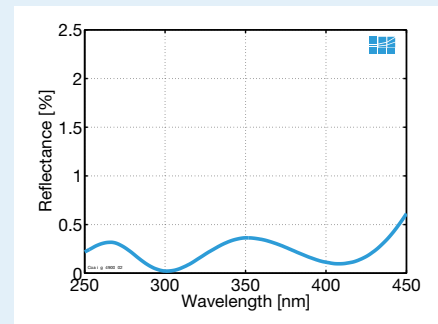


Table 7 Optics Options for Fiber Couplers Type 60FC-...-XV

row	curr. no	1	2	3	4	5
1	Lens Code	S9	S12	S15	S18	S24
2	Focal length f'	9	12	15	18	24
3	Numerical aperture NA**	0.28	0.20	0.16	0.14	0.10
4	Clear aperture max. [mm]	5	5	5	5	5
5	Coll. beam diameter (1/e ²) [mm]*	0.45	0.60	0.75	0.9	1.2
6	Beam diverg. [mrad]*	0.44	0.33	0.27	0.22	0.17
Spectral range		Code no. of AR coating * Calculated for $NA_e^2 = 0.025$ and $\lambda = 313$ nm				
7	250 - 420 nm	49	49	49	49	49
8	for UH vacuum	x	x	x	x	x
9	Dimensions	1	1	1	1	1

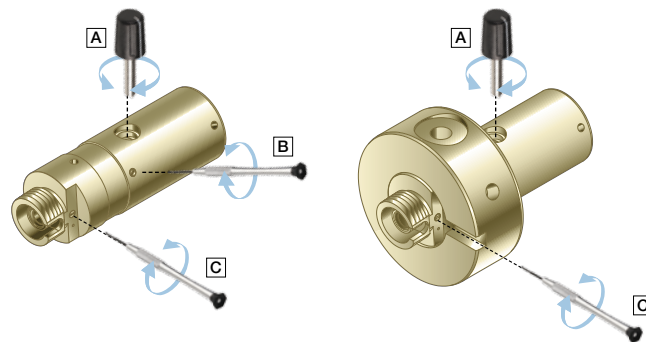
Other optics on request. ** Optics suitable only for $NA_e^2 < 0.04$.

Coating - 49

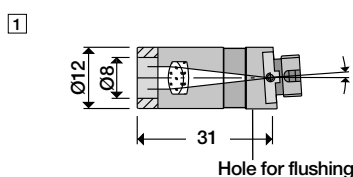


Assembly and Adjustment Tools

- A** Focusing of the collimator
Tool: Eccentric key **Order Code 60EX-5**
or as an alternative:
Tool: Eccentric key with long handle **Order Code 60EX-5-L**
- B** Locking of focus position
Tool: Screwdriver **Order Code 9D-12**
- C** Locking of fiber ferrule with grub screw
Tool: Screwdriver **Order Code 9D-12**



Dimensions 60FC-...-XV



Order options for Fiber Couplers 60FC-...-XV

Order Code 60FC-4-S24-49-XV

- AR Coating: Table 7, row 7
- Lens type: Table 7, row 1
- 4 = FC-APC
- 0 = FC-PC

Order Code Adapter

Order Code 12AM25-M5

- M3 flush connection
- M4 flush connection
- M5 flush connection

Fiber Collimators Type 60FC-L and 60FC-T

for collimating radiation exiting from an optical fiber to a large beam diameter or for coupling a beam into an optical fiber

- Focal lengths up to 200 mm, large apertures
- Choice of monochromats or achromats (lens type overview p.14)
- Various AR coatings for UV - IR
- Choice of fiber receptacles: FC PC or FC APC (standard), many others available
- Adjustable focus setting
- Front connector accepts attachment optics
- Copper alloy / aluminum (standard) or amagnetic titanium

Additional features of type 60FC-T:

integrated TILT adjustment, for aligning the beam axis with the mechanical axis, so there is:

- no vignetting of the collimated beam
- no asymmetric diffraction arising from a clipped beam



Table 8 Optics Options for Fiber Collimators Type 60FC-L / 60FC-T (Partial selection only. More on www.sukhamburg.com)

curr. no Lfd. Nr.	1	2	3	4	5	6	7	8	9	10	11	12	13	14	15
1 Lens code	M20L	M25	M30	M35	M40	M60	M40L	M50L	M60L	M75	M100S	M125	M100	M150	M200
2 Focal length f'	20	25	30	35	40	60	40	50	60	75	100	125	100	150	200
3 Numerical aperture NA	0.17**	0.23	0.22	0.15	0.20	0.14	0.30	0.24	0.20	0.16	0.12	0.15	0.24	0.16	0.12
4 Clear aperture max. [mm]	6.8**	13	13	14	16	16	24	24	24	24	24	38	48	48	48
5 Coll. beam diameter [mm]*	3.6	4.5	5.4	6.3	7.2	10.9	7.2	9.0	10.8	13.5	18.0	22.5	18.0	26.9	35.9
6 Beam divergence [mrad]*	0.12	0.1	0.08	0.07	0.06	0.04	0.06	0.05	0.04	0.03	0.02	0.02	0.02	0.02	0.01
7 Correction - achromatic	x	x	x	x			x	x	x	x	x		x	x	x

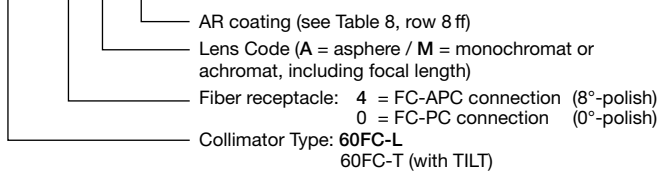
Spectral range	Code no. of AR coating * Calculated for $\lambda = 670$ nm and $NAe^2 = 0.09$, ** min.value															
8 390 - 670 nm	33														33	
9 400 - 670 nm	47															
10 630 - 980 nm	10														10	
11 630 - 1080 nm	54												54			
12 980 - 1550 nm	08														08	
13 420 - 700 nm	26				26	26	26		26	26	26				26	
14 750 - 1550 nm	37	37		37	37				37	37	37			37	37	
15 400 - 700 nm	01	01	01	01					01	01	01			01	01	
16 650 - 1050 nm	02	02	02	02					02	02	02			02	02	
17 1050 - 1620 nm	03	03	03						03							
18 450 - 700 nm	04	04	04	04		04								04		
19 725 - 1200 nm	40															
19 Housing diameter \varnothing		25/(28)	25/(28)	25/(28)	25/(28)	25/(28)	25/(28)	32/34.5	32/34.5	32/34.5	32/34.5	32/34.5	45/49	55/59	55/59	55/59
20 Front fitting		\varnothing 19.5	\varnothing 19.5	\varnothing 19.5	\varnothing 19.5	\varnothing 19.5	\varnothing 19.5	M27x0.5	M27x0.5	M27x0.5	M27x0.5	M27x0.5	M43x0.75	\varnothing 52	\varnothing 52	\varnothing 52
21 Dimensions	60FC-L (w/o TILT)	[1]	[2]	[2]	[3]	[3]	[4]	[5]		[6]	[7]		-	[9]	[10]	
22 Dimensions	60FC-T (with TILT)	[2]	[2]	[2]	[3]	[3]	[4]	[5]		[6]	[7]	[8]	p. 35	[9]	[10]	
23 Clamping flange	60FC-L	x	x	x	x	x	x	x	x	x	x	x	x	x	x	x
24	60FC-T							x	x	x	x	x	x	x	x	x

Table 8.1 Beam diameter as a function of the working distance A. (Calculated for $NAe^2 = 0.09$ and $\lambda = 670$ nm)

Lens type	M20L	M25	M30	M35	M40	RGBV42	M60	M50L	M40L	M60L	M75	M100S	M125	M100	M150	M200	
24 Focal length f'	20	25	30	35	40	42	60.5	50	40	60	75	100	125	100	150	200	
Beam diameter at distance A [mm]																	
28 Collimated	5 m	3.8	4.6	5.4	6.3	7.2	7.6	10.9	9.0	7.2	10.8	13.5	18.0	22.5	18.0	26.9	35.9
29	10 m	4.3	4.9	5.6	6.4	7.3	7.6	10.9	9.1	7.3	10.8	13.5	18.0	22.5	18.0	26.9	35.9
30	20 m	6.0	5.9	6.2	6.8	7.6	7.9	11.0	9.2	7.6	10.9	13.5	18.0	22.5	18.0	26.9	35.9

Order options for fiber collimators type 60FC-L and type 60FC-T

Order Code 60FC-T-4-M60-10



Material Option:

Add **T** for titanium housing (amagnetic):

Order Code Example: 60FC-T-4-M60-10-T

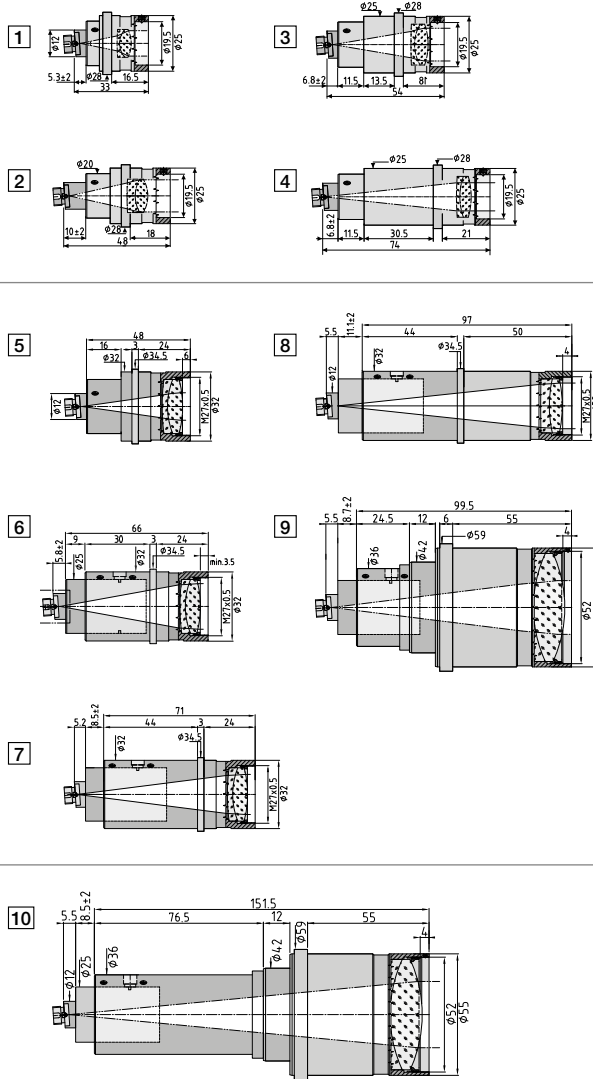
Option: LSA (comp. with DIN, AVIO and AVIM), and SMA-905 (F-SMA)

Dimensions and Adjustment

Dimensions

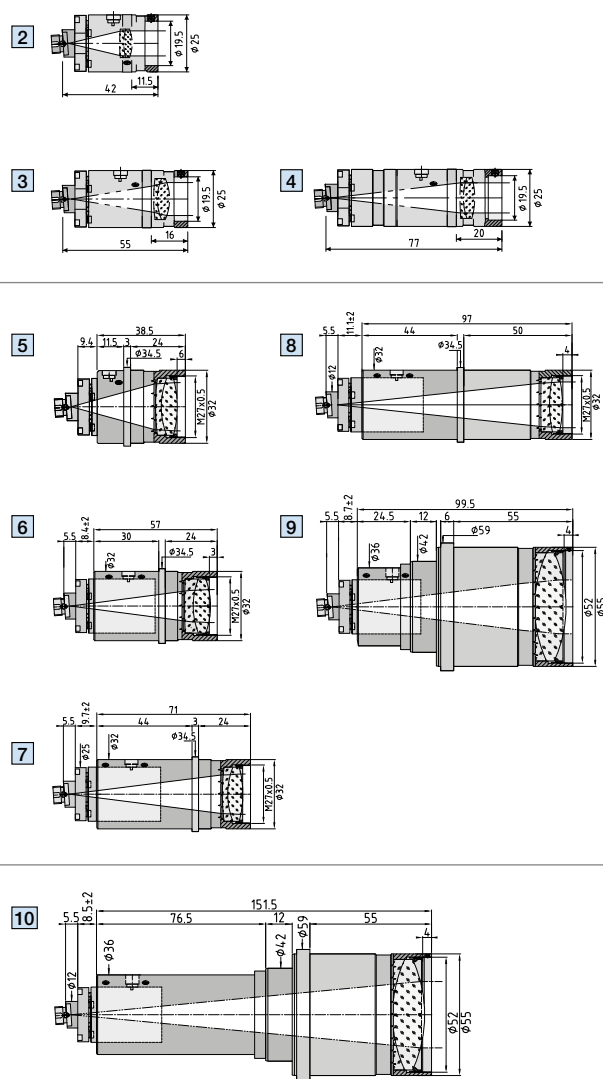
Fiber collimator 60FC-L

All fiber collimators of type 60FC-L possess a flange for a low-strain mounting together with clamp collars of type CC, see page 30.



Fiber collimator 60FC-T with TILT adjustment

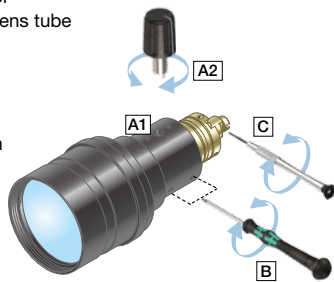
Fiber collimators of type 60FC-T with housing $\phi \geq 32$ mm possess a flange for low-strain mounting together with clamp collars of type CC, see page 30.



Assembly and Adjustment Tools

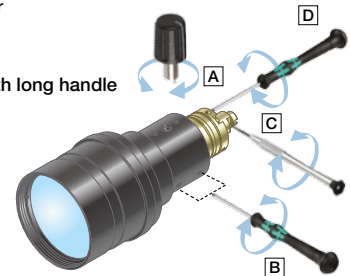
For Type 60FC-L

- A1** for Type 60FC-L **1-5**
Focusing of the collimator by manually shifting the lens tube
- A2** for Type 60FC-L **6-10**
Tool: Eccentric key
Order Code 55EX-5
- B** Locking of focus position
Tool: Hex screwdriver
Order Code 50HD-15
- C** Locking of fiber ferrule with grub screw
Tool: Screwdriver
Order Code 9D-12



For Type 60FC-T

- A** Focusing of the collimator
Tool: Eccentric key
Order Code 55EX-5
or Tool: Eccentric key with long handle
Order Code 55EX-5-L
- B** Locking of focus position
Tool: Hex screwdriver
Order Code 50HD-15
- C** Locking of fiber ferrule with grub screw
Tool: Screwdriver
Order Code 9D-12
- D** Tilt adjustment
Tool: Hex screwdriver **Order Code** 50HD-15



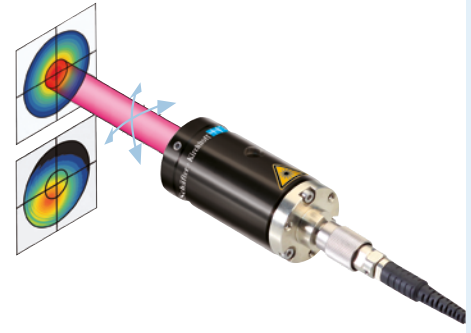
TILT adjustment for type 60FC-T

For an optimal performance of the collimated beam, the fiber collimator type 60FC-T has an integrated tilt mechanism.

The TILT adjustment is used to align the beam axis with the mechanical axis

Advantages:

- no vignetting of the collimated beam
- no asymmetric diffraction arising from a clipped beam



Accessories: Clamp Collars Type CC

Fiber collimators of type 60FC-L and 60FC-T (starting from No. 8 of Table 8) [1] are firmly attached using clamp collars CC-... [A] to an arbitrary counterpart [3] or other setup.

The locking of the clamp collars ensures a stable mounting of the fiber collimators without adding strain. The clamp collars are available in four sizes (see Table 9) and are mounted using 4 screws.

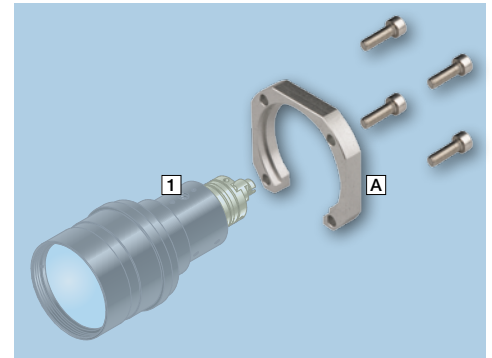
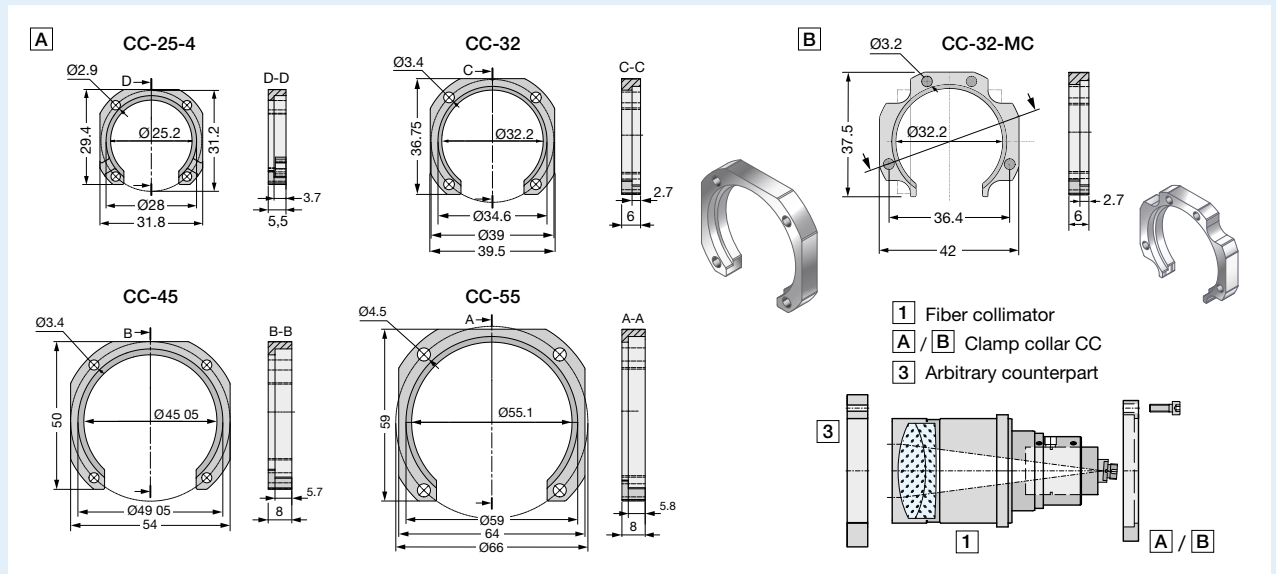


Table 9 Clamp Collars Type CC

	Table 8 / No 1 - 6*	Table 8 / No 7 - 11	Table 8 / No 7 - 11	Table 8 / No 12	Table 8 / No 13 - 15
1 For collimator:	Table 8 / No 1 - 6*	Table 8 / No 7 - 11	Table 8 / No 7 - 11	Table 8 / No 12	Table 8 / No 13 - 15
2 Order Code	CC-25-4	CC-32	CC-32-MC	CC-45	CC-55
3 Clear aperture [mm]	Ø25.2	Ø32.2	Ø32.2	Ø45	Ø55.1
4 Bore holes (4 x 90°)	2.9	3.4	3.2	3.4	4.5
7 Depth [mm]	3.7	2.7	2.7	5.7	5.8
8 Thickness [mm]	5.5	6	6	8	8
9 Suitable multicube plate**	48MC-MP-25	-	48MC-MP-32	48MC-MP-45	48MC-MP-55

* Optional: fiber collimators type 60FC-L with flange ** see page 75

Dimensions



Attachment optics: Micro Focus Optics Type 13M / 25M

Transforms a collimated laser beam into a micro focus spot

- Attachment optics for fiber collimators of type 60FC-L or 60FC-T
- Type 13M for collimators with outer Ø 25 mm
- Type 25M for collimators with outer Ø 32 mm
- Choice of achromats or singlet lenses
- Various optics for UV - IR

Further information:
www.sukhamburg.com



Table 10		Optics Options for Micro Focus Optics 13M (Partial selection only. More on www.sukhamburg.com)											
row		curr. no	1	2	3	4	5	6	7	8	9	10	11
1		Lens type	M25	M30	M40	M50	M60	M75	M100	M125	S250	S500	S1000
2		Focal length f'	25	30	40	50	60	75	100	125	250	500	1000
3		Numerical aperture	0.23*	0.16*	0.15	0.15	0.125	0.09	0.06	0.06	0.03	0.016	0.007
4		Clear aperture max. (mm)	11.5*	11.5*	15.0	15.0	15.0	15.0	13.5	13.5	13.5	13.5	13.5

Spectral range	Code no. of AR coating												
	* min. value			** wavelength dependent									
5 400 - 700 nm	01	01											
6 390 - 670 nm	33					33					33	33	33
7 450 - 700 nm	04			04		04		04					
8 420 - 700 nm	26	26	26		26		26		26				
9 630 - 980 nm	10					10				10			
10 630 - 1080 nm	54			54									
11 750 - 1550 nm	37	37	37	37									
12 980 - 1550 nm	08					08							
13 600 - 1060 nm	05										05	05	05

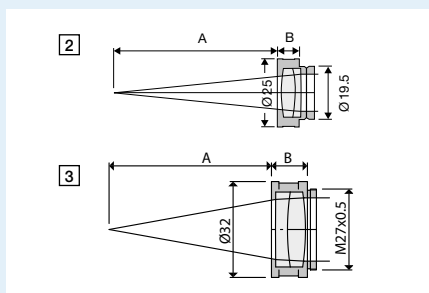
14	Dimensions drawing												
15	Length B [mm]	8	8	8	8	8	8	8	8	8	8	8	8
16	Working distance A [mm]**	20	25	33	43	54	69	93	120	245	492	973	
17	Suitable for UH vacuum									X	X	X	

Table 11		Optics Options for Micro Focus Optics 25M for fiber collimators 60FC-L or 60FC-T with outer Ø 32 mm											
row		curr. no	1	2	3	4	5	6	7	8	9		
1		Lens type	M35	M50	M75	M100	M150	M200	M300	S300	S500		
2		Focal length f'	35	50	50	100	150	200	300	300	500		
3		Numerical aperture	0.34	0.23	0.18	0.18	0.08	0.06	0.04	0.04	0.023		
4		Clear aperture max. (mm)	23.4	23.4	23.4	23.4	23.4	23.4	23.4	23.4	23.4		

Spectral range	Code no. of AR coating												
	** wavelength dependent												
5 420 - 700 nm	26	26	26	26	26	26	26	26	26	26	26		
6 750 - 1550 nm	37		37	37	37	37	37	37		37	37		

7	Dimensions drawing												
8	Length B [mm]	8	12	12	12	12	14	12	12	12			
9	Working distance A [mm]**	28.8	41.9	66.7	92.3	142	192	292	292	492			
10	Suitable for UH vacuum									x	x		

Dimensions



Order Options for Micro Focus Optics Type 13M/25M

Order Code 13M - M60 - 13 - S

- AR Coating, see Table 10 – 11, from row 5
- Lens Code (M = monochromat or achromat, S = singlet) including focal length
- Series: **13M** for fiber collimators with outer Ø 25 mm, Table 10
- 25M** with outer Ø 32 mm, Table 11

Attachment optics: Polarization Filters Type 13PF

Polarization filters with system mount \varnothing 19.5 mm for attaching to 60FC-L and 60FC-T Fiber Collimators with outer diameter \varnothing 25 mm. These filters transmit only the linear polarized component of the radiation.

- Free rotation for best adjustment with positional locking using radially arranged screws.
- Polarization extinction ratio 10.000:1
- Surface deviation $< \lambda/4$
- Wavelength range UV - IR
- Broadband AR Coating
- Optional long-form housing (-L) ([6] and [8]) with system mount \varnothing 19.5 mm for adding additional attachment optics

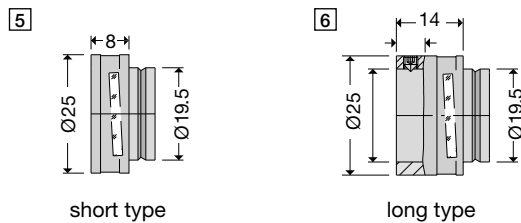


Polarization beam splitter cubes with deflection of the unwanted orthogonally polarized radiation
Dichroic polarization filters: The filter is laminated to a glass substrate with an 0.5° inclined mounting in order to avoid direct back-reflections filters

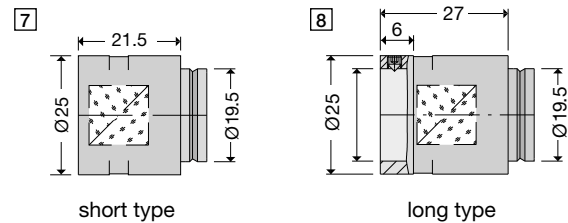
row	Series	Polarizer type	Spectral range	Extinction	Transmission	Clear aperture (mm)	Polarization filter (short) Order Code	Figure	Polarization filter (long) Order Code	Figure
1	13PF-P		600 - 850	10 ⁴ :1	>84-93	12	13PF-P - 600-S	[5]	13PF-P - 600-L	[6]
2			750 - 1250	10 ⁴ :1	>87-93	12	13PF-P - 750-S		13PF-P - 750-L	
3			1280 - 1500	10 ⁴ :1	>96-98	12	13PF-P-1300-S		13PF-P-1300-L	
4	13PF-C		340 - 440	5x10 ⁴ :1	>98	8	13PF-C - 350-S	[7]	13PF-C - 350-L	[8]
5			450 - 700	10 ⁴ :1	>95	10	13PF-C - 450-S		13PF-C - 450-L	
6			750 - 1100	10 ⁴ :1	>95	10	13PF-C - 750-S		13PF-C - 750-L	
7			1100 - 1700	10 ⁴ :1	>98	10	13PF-C-1100-S		13PF-C-1100-L	

Dimensions

Dichroic glass polarizers 5PF-P



Polarizing beam-splitter cubes 13PF-C



Attachment Optics:

Iris Diaphragms Type 13BL, 25BL and 40BL and Pinholes Type 13H

Iris diaphragms and pinholes are used to reduce the diameter of a collimated beam.

- Attachment optics for fiber collimators type 60FC-L or 60FC-T with outer diameter \varnothing 25 mm (Series 13BL), \varnothing 32 mm (Series 25BL), \varnothing 55 mm (Series 40BL)
- Iris diaphragm with variable aperture, pinholes with fixed aperture
- **Please note:** In case of use with a single mode / PM-fiber, the Gaussian beam from the fiber collimator is truncated by the iris diaphragm or by the pinhole



row	Series	\varnothing min - max [mm]	Order Code	Mounting
1	13BL	0 - 12	13BL0-12	\varnothing 19.5 mm
2	13BL	1 - 13	13BL1-13	\varnothing 19.5 mm
3	13H	0.5	13H0.5	\varnothing 19.5 mm
4	13H	0.8	13H0.8	\varnothing 19.5 mm
5	13H	1	13H1.0	\varnothing 19.5 mm
6	25BL	1 - 20	25BL1-20	M27x0.5
7	40BL	2 - 42	40BL2-42	\varnothing 52 mm

Partial selection only. More on www.sukhamburg.com

Fiber Collimator 60FC-SF with super-fine focussing mechanism

Fiber Collimator/Fiber Coupler with focus adjustment using a super-fine thread

The Fiber Collimators series 60FC-SF with super-fine thread are an improved, advanced version of the series 60FC-F collimators. They are designed for collimating radiation exiting from an optical fiber cable or used in reverse as a fiber coupler (fiber port) for incoupling. The focus adjustment is done using a super-fine-threaded ring.

- Increased pointing stability and reduced backlash during the focus setting
- Super-fine thread for an even more precise focus setting with 0.35 mm pitch
- Focal lengths up to 18 mm
- Choice of aspheres*, achromats and apochromats (p. 14)
- Various AR coatings for UV - IR
- Choice of fiber receptacles: FC PC or FC APC (standard), many others available
- Compact Ø 12 mm housing

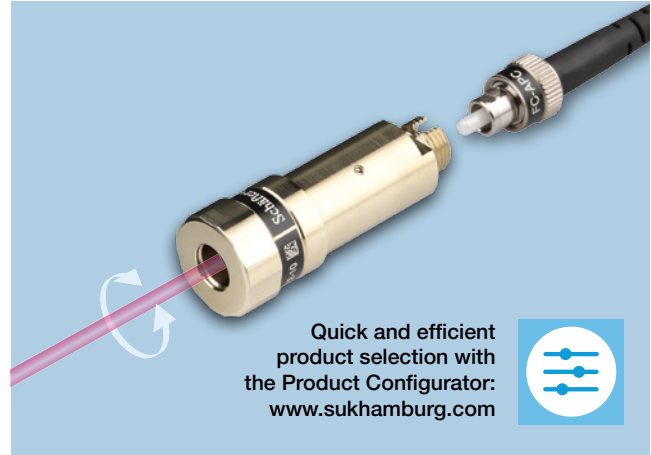


Table 14

Optics Options for Fiber Collimators Type 60FC-SF (Partial selection only. More on www.sukhamburg.com)

row	curr. no	1	2	3	4	5	6	7	8	9	10	11	12	13	14	15	16
1	Lens Code	A4.5S	A4.5	M5	A6.2S	A6.2	M6.2	A7.5	A8	M8	A11	M11	M12	M12NIR	A15	M15	A18
2	Focal length f'	4.5	4.5	5.1	6.16	6.2	6.2	7.5	8	8.1	11	11	12	12	15.4	15	18.4
3	Numerical aperture NA	0.42	0.5	0.25	0.24	0.4	0.2	0.3	0.3	0.16	0.25	0.23	0.23	0.23	0.16	0.18	0.15
4	Clear aperture max. [mm]	3.7	3.9	2.5	3.7	3.2	2.5	4.7	4.9	2.5	5.5	5	5.5	5.5	5	5.5	5.5
5	Coll. beam diameter [mm]**	0.81	0.81	0.92	1.11	1.11	1.11	1.35	1.44	1.45	1.97	1.97	2.15	2.15	2.76	2.69	3.3
6	Beam divergence [mrad]**	0.53	0.53	0.47	0.39	0.39	0.39	0.32	0.3	0.29	0.22	0.22	0.2	0.2	0.15	0.16	0.13
7	Correction - achromatic			x			x							x		x	
8	Coupling/MM only*	x			x			x			x				x		x

9	Spectral range	Code no. of AR coating * Coupling / multimode collimation only ** Calculated for NAe ² = 0.09 and λ = 670 nm																
9	400 - 600 nm	01	01			01				01						01		01
10	600 - 1050 nm	02	02			02				02						02		02
11	1050 - 1550 nm	03	03			03				03						03		03
12	1300 - 1750 nm	45	45			45				45						45		45
13	1750 - 2150 nm	09	09			09				09								
14	390 - 670 nm	33			33								33					
15	630 - 980 nm	10			10							10		10				
16	980 - 1550 nm	08			08							08		08				
17	420 - 700 nm	26																26
18	750 - 1550 nm	37																37
19	400 - 670 nm	51																
20	520 - 830 nm	18											18					
21	650 - 1150 nm	07		07				07		07								

Table 14.1

Beam diameter as a function of the working distance A.

22	Collimated	Lens type	A4.5S	A4.5	M5	A6.2S	A6.2	M6.2	A7.5	A8	M8	A11	M11	M12	M12NIR	A15	M15	A18
23		Focal length f'	4.5	4.5	5.1	6.16	6.2	6.2	7.5	8	8.1	11	11	12	12	15.4	15	18.4
24		Beam diameter at distance A [mm]																
25		0.5 m	0.97	0.97	1.03	1.17	1.17	1.17	1.38	1.47	1.48	2.0	2.0	2.2	2.7	2.8	2.8	3.3
26	Distance A	1.0 m	1.33	1.33	1.31	1.35	1.35	1.35	1.49	1.55	1.6	2.0	2.0	2.2	2.7	2.8	2.8	3.3
27		5.0 m	5.3	5.3	4.7	4.0	4.0	4.0	3.4	3.3	3.3	2.9	2.9	2.9	3.1	3.2	3.2	3.5

Table 14.2

Diameter of focused beam as a function of the working distance. For spot Ø <100 µm, micro focus optics are used.

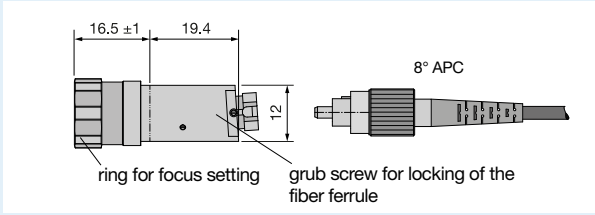
28	Focused	Lens type	A4.5S	A4.5	M5	A6.2S	A6.2	M6.2	A7.5	A8	M8	A11	M11	M12	M12NIR	A15	M15	A18
29		Focal length f'	4.5	4.5	5.1	6.16	6.2	6.2	7.5	8	8.1	11	11	12	12	15.4	15	18.4
30		Spot diameter at distance A [mm]																
31		0.5 m	0.53	0.53	0.47	0.39	0.39	0.39	0.32	0.30	0.29	0.22	0.22	0.20	0.20	0.15	0.16	0.13
32	Distance A	1.0 m	1.06	1.06	0.93	0.77	0.77	0.77	0.63	0.59	0.59	0.43	0.43	0.40	0.40	0.31	0.32	0.26
33		5.0 m	-	-	4.66	3.86	3.86	3.86	3.17	2.97	2.93	2.16	2.16	1.98	1.98	1.54	1.58	1.29

Table 14.3

Pilot beam: approx. constant beam Ø across entire working range A is achieved by fine adjustment. Position of beam waist at A2.

34	Pilot beam		Beam diameter [mm]			
35	Diagram showing beam waist at A2 and working range A.		Tab. 14 No. 12: M12 / f'=12.			
36			at A	at coll.	at waist	A2 [m]
37	Working range A	0.5 m	2.18	2.18	2.17	0.25
38		1.0 m	2.18	2.18	2.17	0.50
39		2.0 m	2.18	2.18	2.14	1.00
40		5.0 m	2.24	2.18	1.90	2.50
41		10.0 m	4.07	2.18	2.09	5.00
42		20.0 m	7.93	2.18	2.09	10.00
43		50.0 m	19.7	2.18	2.09	25.00

Dimensions 60FC-SF



Adjustment Tools

Screwdriver

Order Code 9D-12



Order Options for Fiber Collimators 60FC-SF

Order Code 60FC-SF-4-M12-33

- AR coating (see Table 14, row 9 – 21)
- Lens Code (A = asphere / M = monochromat or achromat) including focal length
- Fiber receptacle:
4 = FC-APC connection (8°-polish)
0 = FC-PC connection (0°-polish)

Option: LSA (comp. with DIN, AVIO and AVIM) and SMA-905 (F-SMA)

Accessories: Adapters for fiber collimators of type 60FC/60FC-SF

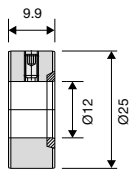
Suitable for fiber collimators type 60FC/60FC-SF with diameter Ø 12 mm

- Adapters for outer Ø 25 mm, Ø 1" (25.4 mm) e.g. for use with standard mirror mounts or with system mount Ø 19.5 mm.
- Adapter type 12AM-19.5: Ideal for incorporation in a microbench / cage system, with mounting brackets and the construction kit multicube™ from Schäfter+Kirchhoff.

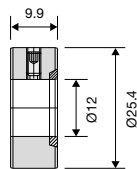


Dimensions Adapter Types

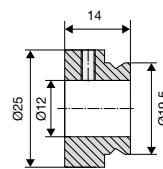
1 Type 12C-AM25



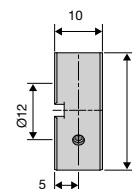
2 Type 12AM25.4



3 Type 12AM-19.5



4 Type 12AM25-M4



Order Options for the Adapters

1 Order-Code 12C-AM25 for outer Ø 25 mm

2 Order-Code 12AM25.4 outer Ø 25.4 mm

3 Order-Code 12AM-19.5 with system mount Ø 19.5 mm

4 Order-Code 12AM25-M4 with M4 thread for post-mount

Accessories: Holder for fiber collimators of type 60FC/60FC-SF

Suitable holder for fiber collimators of type 60FC/60FC-SF:

- MDI-HS-2-3012T from Radiant Dyes.
- For details and enquiries: www.radiant-dyes.com



Fiber Collimators 60FC-Q

Fiber Collimator for collimating large beam diameters and with integrated quarter-wave plate

The fiber collimators series 60FC-Q are designed for collimating radiation exiting from an optical fiber cable. An integrated adjustable quarter-wave plate is used to generate left-handed or right-handed circularly polarized radiation.

- Large beam diameters: Focal lengths up to 200 mm
- Choice of monochromats or achromats
- Various AR coatings for UV - IR
- Low-order retardation optics with minimal angular dependency
- Choice of fiber receptacals: FC PC or FC APC (standard), many others available
- Adjustable focus setting
- Integrated TILT adjustment to prevent aberrations from vignetting or clipping
- Front connector accepts attachment optics
- Adjustment in the assembled state using a coggled tool and Polarization Analyzer SK010PA



Quick and efficient product selection with the Product Configurator:
www.sukhamburg.com



Table 15 Optics options for Fiber Collimator 60FC-Q (Partial selection only. More on www.sukhamburg.com)

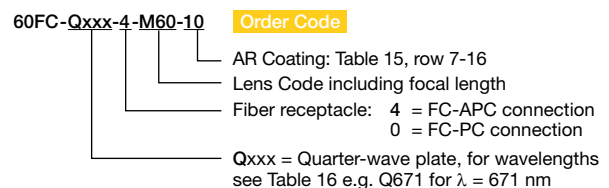
row	curr. no	1	2	3	4	5	6	7	8	9	10	11	1
1	Lens Code	M20L	M30	M35	M40	M60	M60 L	M75	M100 S	M100	M125	M150	M200
2	Focal length f'	20	30	35	40	60	60	75	100	100	125	150	200
3	Numerical aperture NA	0.17**	0.22**	0.15	0.20	0.14	0.20	0.16	0.12	0.24	0.15	0.16	0.12
4	Clear aperture max. [mm]	8.8**	13**	14	16	16	24	24	24	38	38	48	48
5	Coll. beam diameter* [mm]	3.6	4.5	6.3	7.2	10.9	10.8	13.5	18.0	18.0	22.5	26.9	35.9
6	Beam divergence* [mrad]	0.12	0.08	0.07	0.06	0.04	0.04	0.03	0.02	0.02	0.02	0.02	0.01

	Spectral range	Code no. of AR coating * Calculated for NAe ² = 0.09 and λ = 670 nm ** min. value												
7	400 - 600 nm	01	01	01					01				01	01
8	650 - 1050 nm	02	02	02				02	02		02			02
9	1050 - 1550 nm	03	03						03					
10	390 - 670 nm	33												
11	630 - 980 nm	10												
12	630 - 1080 nm	54				54							54	
13	980 - 1550 nm	08												
14	420 - 700 nm	26			26	26		26	26	26			26	
15	750 - 1550 nm	37		37	37			37	37	37			37	37
16	450 - 700 nm	04	04	04		04	04						04	04
17	Housing diameter Ø		25	25	25	25	25	32/34.5	32/34.5	32/34.5	55/59	45/49	55/59	55/59
18	Front fitting		Ø 19.5	Ø 19.5	Ø 19.5	Ø 19.5	Ø 19.5	M27x0.5	M27x0.5	M27x0.5	Ø 52	M43x0.7	Ø 52	Ø 52
19	Dimensional drawing			1	1	1	2	4	5	6		3	7	

Table 16 Typical wavelengths

Element	λ [nm]	Element	λ [nm]
Helium	He 389	Strontium	Sr 689
Strontium	Sr 461	Sodium	Na 760
Ytterbium	Yb 556	Potassium	K 767
Sodium	Na 589	Rubidium	Rb 780
Lithium	Li 671	Krypton	Kr 811
Helium	He 1084	Caesium	Cs 852

Order options for elliptical Fiber collimator 60FC-Q



Optional connector types:
LSA (comp. with DIN, AVIO and AVIM) or F-SMA

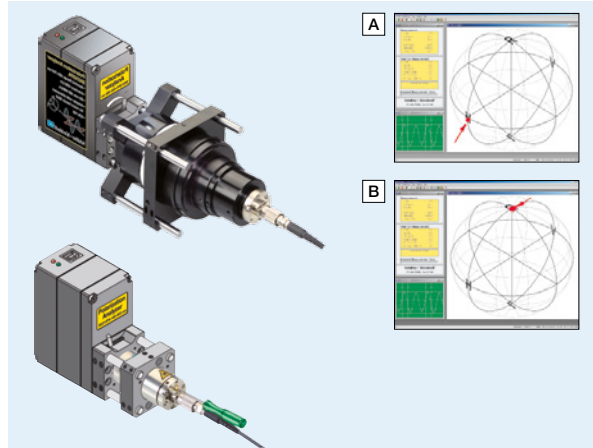
Assembly and Adjustment

Adjustment of the Quarter-Wave Plate

- The adjustment of the retardation optics is achieved using the SK010PA Polarization Analyzer from Schäfter+Kirchhoff
- Microbench or cage system components can be attached to the Polarization Analyzer
- Adjustment of the retardation optics using specially designed cogged tool
- Real-time display of the current polarization state on a Poincaré sphere.

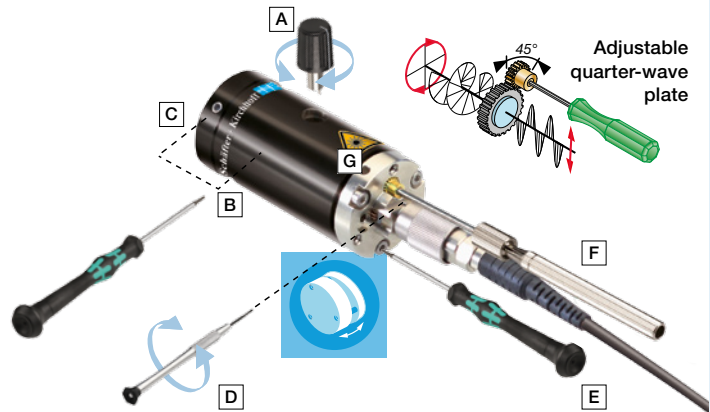
The collimators are attached to the Polarization Analyzer using a microbench or cage system adapter.

Screenshots show the original elliptical **A** and corrected **B** circular states of polarization. After removal of the special adjustment tool and tightening of the two locking screws, the retardation plate is protected against unintentional displacement during use or shipment, see below.

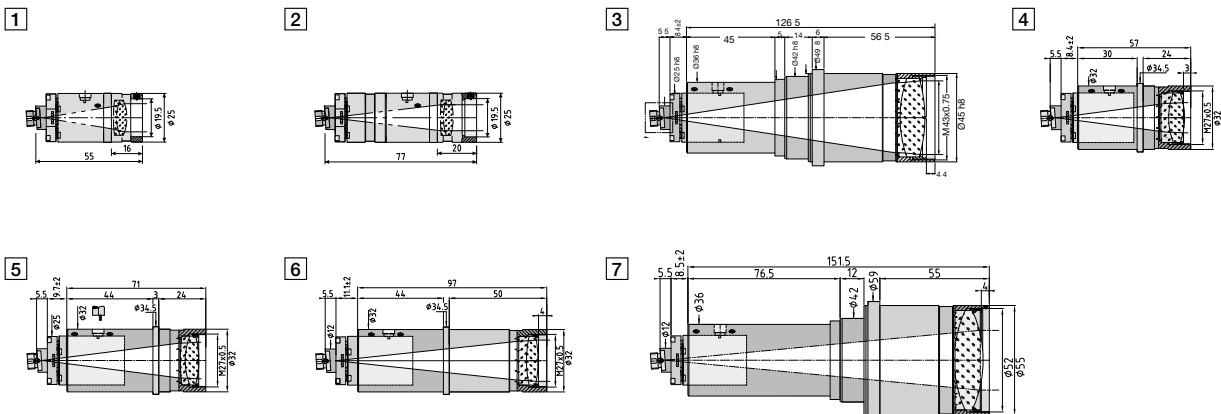


Assembly and adjustment tools

- A** Focus setting
Tool: Eccentric key Order Code 55EX-5
or as an alternative:
Tool: Eccentric key with a long handle Order Code 55EX-5-L
- B** Locking of the focus position and
- C** Locking of attachment optics
Tool: Hex screwdriver Order Code 50HD-15
- D** Locking of fiber ferrule with grub screw
Tool: Screwdriver Order Code 9D-12
- E** TILT adjustment
Tool: Hex screwdriver Order Code 50HD-15
- F** Rotary adjustment of the retardation optics
Tool: Alignment key Order Code 60Z-2803
- G** Grub screw to lock the wave plate
Tool: Hex screwdriver Order Code 50HD-15



Dimensions



Fiber Collimators 60FC-E for Elliptical Cross-Section

Polarization linear or optionally circularly polarized

Schäfter+Kirchhoff fiber collimators of series 60FC-E have a collimated elliptical beam with an axis ratio of up to 1:3. The state of polarization is linear and can be orientated in parallel with either the long or short elliptical axis.

- Aspect ratio up to 1:3
- Polarization linearly polarized
- Gaussian intensity profiles along both elliptical axes
- Rugged and compact design
- A front-fitting for attachments, such as a diaphragm

Option: Fiber Collimators with elliptical cross-section and integrated quarter-wave plate 60FC-E-Q.



Detailed data sheets, up-to-date technical information, technical drawings including step files, accessories, extensive technotes section and FAQs: www.sukhamburg.com



row	curr. no	1	2	5	4	5
1	Lens type	F30 x 90	F57 x 114	F57 x 170**	F90 x 180	F70 x 210
2	Effective focal length f' [mm]	30 x 90	57 x 114	57 x 170**	90 x 180	70 x 210
3	Coll. beam diameter [mm]*	4.9 x 14.8	9.5 x 18.9	9.5 x 28.3**	14.8 x 29.5	11.2 x 33.6
4	Axis ratio	1:3	1:2	1:3	1:3	1:3
5	Clear aperture [mm]	20	30	30	40	48

Designed for Wavelengths						
6		421 nm				
7		461 nm				
8		671 nm				
9		741 nm				
10			780 nm		780 nm	780 nm
11				852 nm		852 nm

* At the (1/e²-level) and calculated for an appropriate single-mode fiber with NAe² 0.08.

Please note that the final beam diameter strongly depends on the NA of the fiber and can be calculated from the effective focal lengths (row 2)

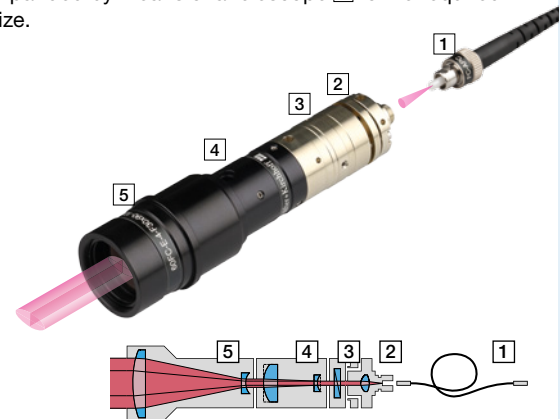
** Beam clipped at the diameter of the clear aperture.

Optical Scheme

The radiation emitted from a single-mode or polarization-maintaining fiber [1] is collimated into a circular beam of approximately 2 mm diameter, [2].

Optionally, the state of polarization can now be transformed by use of a quarter-wave plate [3].

An adjacent anamorphic system [4] expands the beam in only one axis, producing a collimated beam with an elliptical cross section. Finally, the elliptical beam is expanded by means of a telescope [5] to the required size.



Order options for Elliptical Fiber collimators 60FC-E

60FC - E - 4 - F57x114 - 780 Order Code

Design Wavelength [nm]
 Effective focal length [mm]
 4 = FC-APC
 0 = FC-PC

Option:

60FC-E-Qxxx = additional quarter-wave plate for wavelength xxx nm.

Fiber collimators with other effective focal lengths, wavelengths and aspect ratios on request.

Fiber Couplers 60FC-SMA

for SMA-905 high power connectors with 5° or 8°-polish

High precision fiber coupler optimized for high pointing stability and long-term stability – specially designed for SMA-905 high power connectors with 5° or 8°-polish. Efficient coupling of collimated laser radiation into single-mode and PM fiber cables including PCF fibers.

- Focal lengths up to 30 mm
- Choice of aspheres, singlet, monochromats or achromats
- Various AR coatings for UV - IR
- Compatible with high power SMA-905 connector with 5° or 8°-polish
- Focussing of the optics using an eccentric key
- Integrated TILT adjustment to prevent aberrations from vignetting or clipping
- Front connector accepts attachment optics



Table 18 Optics Options for Fiber Coupler 60FC-SMA (Partial selection only. More on www.sukhamburg.com)

row	curr. no.	1	2	3	4	5	6	7	8	9	10	11	12
1	Lens type	A7.5	A8	A11	A15	A18	M20L	M25	M30	M35	M40	S25	S30
2	Focal length f'	7.5	8	11	15.4	18.4	20	25	30	35	40	25	30
3	Numerical aperture NA	0.3	0.3	0.25	0.16	0.15	0.17**	0.23	0.22	0.15	0.20	0.2	0.16
4	Clear aperture max. [mm]	4.5	4.9	5.5	5.5	5.5	6.8**	13	13	14	16	10	9.6
5	Coupling/MM only*												

	Spectral range	Code no. of AR coating * Coupling / multimode collimation only ** min.value											
6	350 - 460 nm	52	52										
7	400 - 600 nm	01	01	01	01	01	01	01	01				
8	600 - 1050 nm	02	02	02	02	02	02	02	02				
9	1050 - 1550 nm	03	03	03	03	03	03	03	03				
10	750 - 1550 nm	37					37		37	37			
11	420 - 700 nm	26								26	26	26	26
12	630 - 1080 nm	54									54		
13	650 - 1150 nm	07	07										

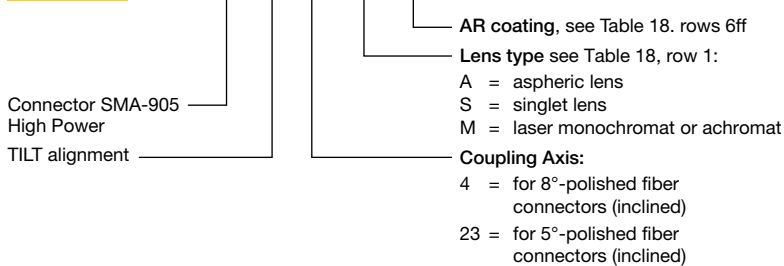
14	Housing diameter Ø	25	25	25	25	25	25	25	25	25	25	25	25
15	Front fitting [mm]	Ø19.5	Ø19.5	Ø19.5	Ø19.5	Ø19.5	Ø19.5	Ø19.5	Ø19.5	Ø19.5	Ø19.5	Ø19.5	Ø19.5
16	Dimensional drawing	□	□	□	□	□	□	□	□	□	□	□	□

Table 18.1 Input/Output beam diameter [mm] (13.5% level)

1	Numerical aperture (13.5%-level) of the fiber	0.03	0.37	0.39	0.54	0.76	0.90	0.98	1.23	1.47	1.72	1.96	1.23	1.47
2		0.05	0.61	0.65	0.90	1.26	1.50	1.63	2.04	2.45	2.86	3.27	2.04	2.45
3		0.07	0.86	0.92	1.26	1.76	2.10	2.29	2.86	3.43	4.00	4.58	-	-
4		0.09	1.10	1.18	1.62	2.27	2.71	2.94	3.68	4.41	5.15	5.88	-	-
5		0.11	1.35	1.44	1.98	2.77	3.3	3.59	4.49	5.39	6.29	7.19	-	-
6		0.13	1.59	1.70	2.34	-	-	4.25	5.31	6.37	7.43	8.50	-	-
7		0.15	1.84	1.96	2.7	-	-	4.90	6.13	7.35	8.58	9.80	-	-
8		0.17	2.08	2.22	3.1	-	-	5.56	6.94	8.33	9.72	11.11	-	-

Order options for Fiber Couplers 60FC-SMA

Order Code 60FC-SMA-T-23-A11-02



Fiber Collimators / Couplers with SMA connector and 0°-polish are available for series 60SMF, 60FC-A19.5, 60FC or 60FC-L.

Assembly and adjustment tools

A Eccentric key for 60FC-SMA-T

Order Code 55EX-5



or as an alternative:

B Eccentric key with a long handle

Order Code 55EX-5-L



D Hex screwdriver

Order Code 50HD-15



Adjustment

Attaching a polarization-maintaining fiber

Unlike the fiber collimators for FC-PC or FC-APC connectors (60SMF or 60FC-T) the fiber connectors of type high power SMA 905 do not have an index key for alignment of the polarization axis of the fiber cable. The axis has to be aligned by hand.

- 1 Fiber Coupler 60FC-SMA
- 2 Tilt adjustment with integrated adjustment and locking screws (with Hex screwdriver 50HD-15)
- 3 Fiber cable with SMA-905 high power connector



More information see page 60

Focus and TILT adjustment

The distance between fiber end-face and collimating optics is adjusted by means of an eccentric key. The lens does not rotate when adjusting the focus. The final focus setting is locked by means of two radially arranged clamping screws. Additionally attachment optics can be mounted to the front of the collimator.

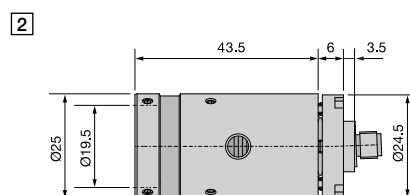
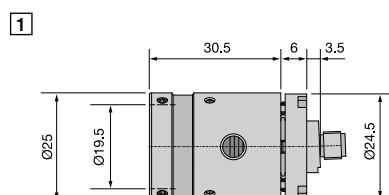
Additionally, the collimator has an integrated TILT adjustment. Unlike common FC-type connectors, the SMA-905 High Power Connector does not have a spring-loaded ferrule.

With varying ferrule length, the point of emission not only shifts axially, but also laterally with respect to the optical axis in the case of an inclined polish (5° and 8°-polish).

By using the TILT adjustment, the point of emission can be adjusted onto the mechanical axis of the fiber coupler. When collimating a laser beam, the integrated TILT adjustment for the fiber coupler 60FC-SMA-T prevents vignetting or asymmetric diffraction arising from a clipped beam.

When coupling into a fiber, high efficiencies can only be reached when the TILT is adjusted properly.

Dimensions

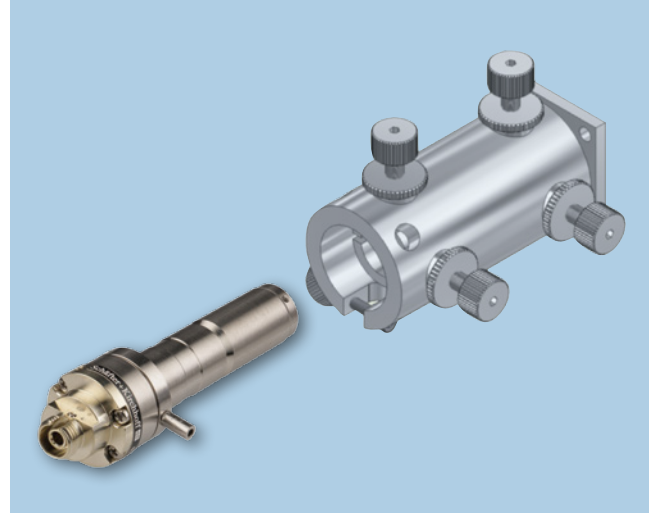


Fiber Couplers 60FC-K

compatible with kineMATIX® Optomechanics (kineMATIX® is a registered trademark of Qioptiq Photonics Limited)

The fiber couplers series 60FC-K are compatible with the kineMATIX® optomechanics and can be used for coupling into single-mode or polarization-maintaining fiber cables or as a fiber collimator.

- Focal lengths up to 18 mm
- Choice of aspheres, monochromats, achromats and apochromats
- Various AR coatings for UV - IR
- Choice of fiber receptacles: FC PC or FC APC (standard), many others available
- Focussing of the optics using an eccentric key
- Compatible with kineMATIX® optomechanics



Quick and efficient product selection with the Product Configurator: www.sukhamburg.com



row	curr. no	1	2	3	4	5	6	7	8	9	10	11	12	13	14	15	16	17	18	19	20	21	22
1	Lens Code	A2.7	A3.1	M3.1	M4	A4	A4.5S	A4.5	M5	A6.2S	A6.2	M6.2	A7.5	A8	M8	A11	M11	RGBV11	M12	M12NIR	A15	M15	A18
2	Focal length f'	2.75	3.1	3.1	4	4	4.5	4.5	5.1	6.2	6.2	6.2	7.5	8	8.1	11	11	11	12	12	15.4	15	18.4
3	Numerical aperture NA	0.55	0.68	0.25	0.25	0.6	0.42	0.5	0.25	0.3	0.4	0.18	0.3	0.3	0.15	0.25	0.23	0.18	0.23	0.23	0.16	0.18	0.15
4	Clear apert. max. [mm]	3.6	5	1.7	2	5	3.7	3.9	2.5	3.7	3.2	2.2	4.5	4.9	2.5	5.5	5	4	5.5	5.5	5	5.5	5.5
5	Coll. beam [mm]*	0.49	0.56	0.56	0.72	0.72	0.81	0.81	0.90	1.12	1.12	1.12	1.35	1.44	1.44	1.98	1.98	1.98	2.16	2.16	2.77	2.7	3.31
6	Beam diverg. [mrad]*	0.86	0.77	0.77	0.59	0.59	0.53	0.53	0.47	0.39	0.39	0.39	0.32	0.3	0.29	0.22	0.22	0.22	0.2	0.2	0.15	0.16	0.13
7	Correction - achrom.			x	x				x						x		x			x		x	
8	Coupling/MM only***	x	x			x	x			x			x			x					x		x

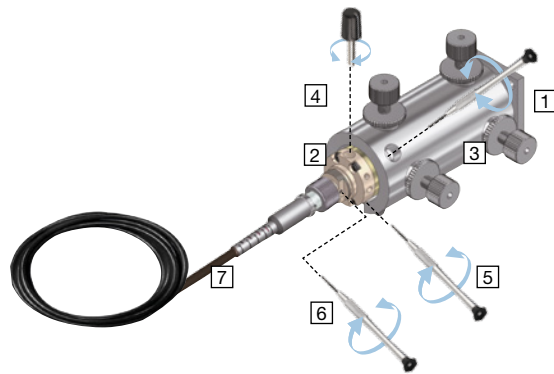
Spectral range	Code no. of AR coating																						
	* Calculated for NAe ² = 0.09 and λ = 670 nm ** IR chalcogenide lens *** Coupling / multimode collimation only																						
9 350 - 460 nm	52	52																					
10 400 - 600 nm	01	01	01		01	01				01			01			01						01	01
11 600 - 1050 nm	02	02	02		02	02				02			02			02						02	02
12 1050 - 1550 nm	03	03	03		03	03				03			03			03						03	03
13 1300 - 1750 nm	45	45	45			45				45			45			45						45	45
14 1750 - 2150 nm	09					09				09			09										
15 390 - 670 nm	33			33					33			33			33					33			
16 630 - 980 nm	10								10						10				10	10			
17 980 - 1550 nm	08								08						08				08				
18 420 - 700 nm	26																						26
19 750 - 1550 nm	37																						37
20 400 - 670 nm	51		51															47					
21 520 - 830 nm	18																18						
22 650 - 1150 nm	07							07			07			07									
23 1750 - 3000 nm	64					64**																	
24 2500 - 6000 nm	63					63**																	

row	curr. no	1	2	3	4	5	6	7	8	9	10	11	12	13	14	15	16	17	18	19	20	21	22
1	Effective numerical aperture of the fiber NAe ² (13.5 % level)	0.04	0.22	0.25	0.25	0.32	0.32	0.36		0.40	0.50	0.50	0.60	0.64	0.64	0.88	0.88	0.88	0.96	0.96	1.23	1.20	1.47
2		0.05	0.27	0.31	0.31	0.40	0.40	0.45		0.50	0.62	0.62	0.75	0.80	0.80	1.10	1.10	1.10	1.20	1.20	1.54	1.50	1.84
3		0.06	0.32	0.37	0.37	0.48	0.48	0.54		0.60	0.74	0.74	0.90	0.96	0.96	1.32	1.32	1.32	1.44	1.44	1.85	1.80	2.21
4		0.07	0.38	0.43	0.43	0.56	0.56	0.63		0.70	0.87	0.87	1.05	1.12	1.12	1.54	1.54	1.54	1.68	1.68	2.16	2.10	2.58
5		0.08	0.43	0.50	0.50	0.64	0.64	0.72		0.80	0.99	0.99	1.20	1.28	1.28	1.76	1.76	1.76	1.92	1.92	2.46	2.40	2.94
6		0.09	0.49	0.56	0.56	0.72	0.72	0.81		0.90	1.12	1.12	1.35	1.44	1.44	1.98	1.98	1.98	2.16	2.16	2.77	2.70	3.31
7		0.22*	1.19	1.36	1.36	1.76	1.76	1.98		2.20	2.73	2.73	3.30	3.52		4.84	4.84		5.28	5.28			

Assembly and adjustment

Assembly and adjustment tools

- 1 kineMATIX™ opto mechanics (not sold by Schäfter+Kirchhoff)
- 2 Fiber Coupler 60FC-K
- 3 Adjustment of polarization axis of the PM-fiber cable to the polarization axis of the laser source
 Tool: **Screwdriver** **Order Code** 9D-12
- 4 Focus setting
 Tool: **Eccentric key**
 for curr. no. 1-17 **Order Code** 60EX-4-L
 for curr. no. 18-21 **Order Code** 60EX-5-L
- 5 Locking of focus position
 Tool: **Screwdriver** **Order Code** 9D-12
- 6 Grub screw for additional fixing of the fiber ferrule
 Tool: **Screwdriver** **Order Code** 9D-12
- 7 Interchangeable fiber cables (single-mode, PM or multimode fiber cable)



Order options for Fiber Coupler 60FC-K

Order Code 60FC-K - 4 - M5 - 33

AR coating, see Table 19

Lens Code:

A = aspheric (beam parameters Table 19, row 1)

M = laser monochromat or achromat

RGBV = laser apochromat

Coupling Axis:

Connector type FC (standard)

4 = inclined coupling axis, APC connector (8°-polish)

0 = coaxial coupling axis, PC connector (0°-polish)

Optional:

LSA = LSA connector (with 0° and 8°-polish)

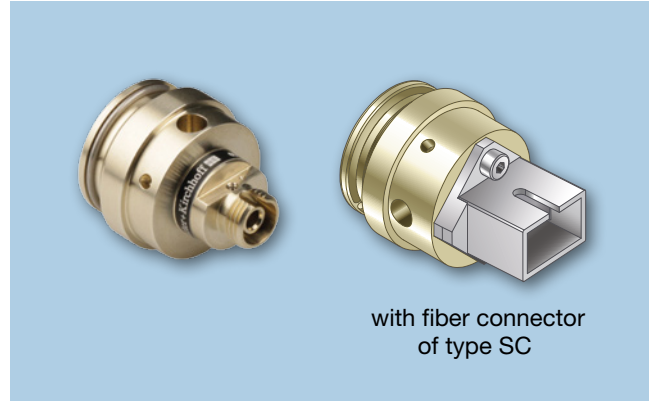
SMA = SMA-905 connector (F-SMA)

Fiber Couplers 60FC-A19.5

for coupling into multimode fiber cables

Fiber coupler (fiber port) with system mount Ø 19.5 mm for multimode fiber coupling.

- For multimode fiber cables or applications that do not require TILT adjustment
- System mount Ø 19.5 mm, fits directly into the multicube™ system
- Integrated focusing adjustment
- Focal lengths up to 18 mm
- Choice of aspheres, monochromats, achromats and apochromats
- Various AR coatings for UV - IR
- Choice of fiber receptacles: FC PC or FC APC (standard), many others available



with fiber connector of type SC

Quick and efficient product selection with the Product Configurator:
www.sukhamburg.com



Table 20

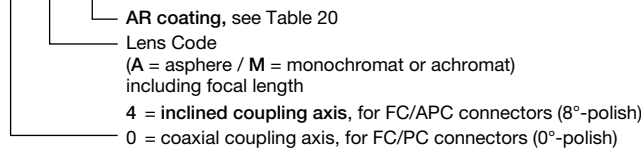
Optics options for Fiber Couplers 60FC-A19.5 (Partial selection only. More on www.sukhamburg.com)

row	curr. no.	1*	2*	3	4	5	6	7	8	9	10	11	12	13	14	15	16	17	18	19	20	21
1	Lens Code	A1.5	A2	A2.7	A3.1	M4	A4	A4.5S	A4.5	M5	A6.2S	A6.2	A7.5	A8	M8	A11	M11	M12	M12NIR	A15	M15	A18
2	Focal length f'	1.5	2	2.75	3.1	4	4	4.5	4.5	5.1	6.16	6.2	7.5	8	8.1	11	11	12	12	15.4	15	18.4
3	Numerical aperture NA	0.5	0.5	0.55	0.68	0.25	0.6	0.42	0.5	0.25	0.3	0.4	0.3	0.3	0.15	0.25	0.23	0.23	0.23	0.16	0.18	0.15
4	Clear aperture max. [mm]	1.5	2	3.6	5	2	5	3.7	3.9	2.5	3.7	3.2	4.5	4.9	2.5	5.5	5	5.5	5.5	5	5.5	5.5
5	Correction achromatic						x				x				x		x		x			x

Spectral Range	Code no. of AR coating	* for multimode fibers only, ** IR chalcogenide lens																					
6 350 - 460 nm	52				52		52																
7 400 - 600 nm	01		01	01	01		01	01			01		01			01					01		01
8 600 - 1050 nm	02		02	02	02		02	02			02		02			02					02		02
9 1050 - 1550 nm	03	03	03	03	03		03	03			03		03			03					03		03
10 1300 - 1750 nm	45			45	45			45			45		45			45					45		45
11 1750 - 2150 nm	09				09			09			09		09	09									
12 390 - 670 nm	33					33					33					33					33		
13 630 - 1080 nm	10										10					10			10	10			
14 980 - 1600 nm	08										08					08			08				
15 420 - 700 nm	26																						26
16 750 - 1550 nm	37																						37
17 400 - 670 nm	51																						
18 460 - 740 nm	53															53							
19 520 - 830 nm	18																		18				
20 650 - 1150 nm	07									07					07								
21 450 - 700 nm	04																						
22 1750 - 3000 nm	64																						64**
23 2500 - 6000 nm	63																						63**

Order Options for Fiber Couplers 60FC-A19.5

Order Code 60FC-A19.5 - 4 - A11 - 02



Optional:

- SC-0 = SC connector
- SMA-0 = SMA-905 connector (F-SMA)

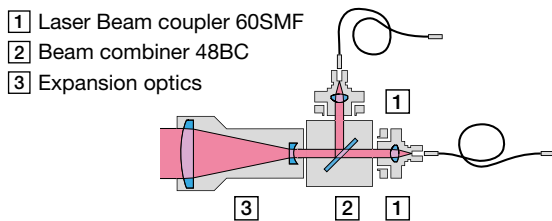
Fiber Collimators 60FC-BC

with Dichroic Beam Combiner

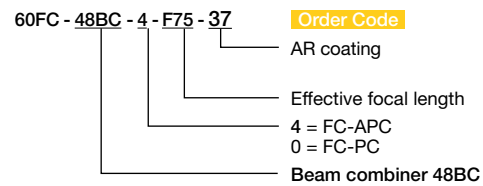
Schäfter+Kirchhoff fiber collimators of series 60FC-BC are designed for dichroic beam combination and collimation. They possess two fiber receptacles and an integrated dichroic beam combiner.

- Two input ports
- Spectral range 400 nm - 1000 nm
- Choice of different focal lengths for the two wavelengths (e.g. for choosing different collimated beam diameters, or for compensating different fiber NAs)
- Polarization linear polarized
- Gaussian intensity profiles
- Compatible with the multicube™ system and cage system
- Rugged and compact design
- Front-fitting for attachments, such as an iris diaphragm

Optical Scheme



Order Options for Fiber Collimators 60FC-48BC



This is only one example of several possible collimator solutions. A large selection of available fiber collimators can be found on www.sukhamburg.com.

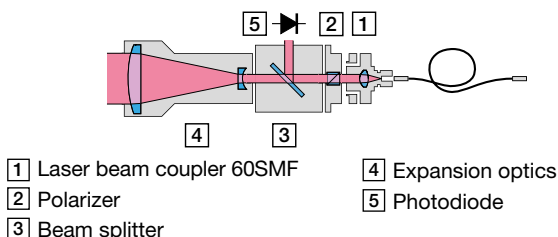
Fiber Collimators 60FC-PD

with Integrated Power Monitor

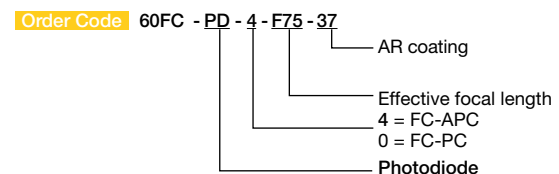
Schäfter+Kirchhoff fiber collimators of series 60FC-PD have an integrated power monitor, so that temporal variations of laser power can be monitored or logged.

- Input polarizer
- Power monitor
- Spectral range 400 nm - 1000 nm
- Gaussian intensity profiles
- Compatible with the multicube™ and microbench/cage system
- system
- Rugged and compact design
- A front-fitting for attachments, such as an iris diaphragm
- Optional: Type 60FC-PD-Q with integrated quarter-wave plate for circular state of polarization

Optical Scheme



Order Options for Fiber Collimators 60FC-PD



This is only one example of several possible collimator solutions. A large selection of available fiber collimators can be found on www.sukhamburg.com.

Anamorphic Beam-Shaping Optics 5AN

Transforms a Collimated Laser Beams with Elliptical Cross-section into a Circular beam or Vice Versa

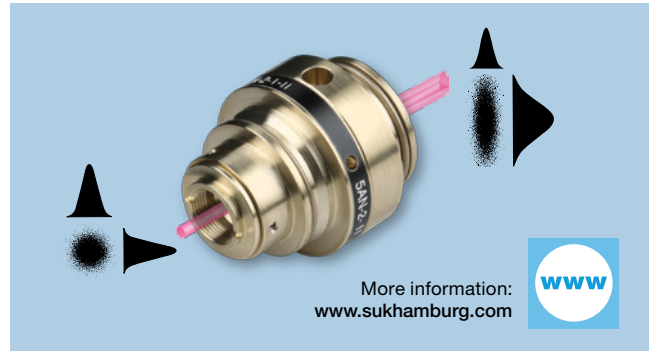
Anamorphic optics act one-dimensionally on the elliptical profile of the collimated beam.

They can be used to

- Adjust the larger beam diameter to the dimension of the smaller one, producing a radially symmetric beam
- Adjust the smaller beam diameter to the dimension of the larger one, producing a radially symmetric beam
- Transform a circular beam into an elliptical one

Enlarge one elliptical axis to produce a beam with a higher axis ratio The Anamorphic Beam-shaping Optics type 5AN are cylinder lens systems and, therefore, can be additionally used to correct the astigmatic difference ΔA_s of the laser diode or tapered amplifier through a refocusing of the optical system. Coupling efficiencies to single-mode fibers of 80% or more are possible when using anamorphic beam-shaping optics (depending on the beam characteristics of the laser diode or tapered amplifier).

- Radially symmetric output beam achieved by down scaling of the longer elliptical axis (beam-shaping factor 0.33 – 0.63)
- Integrated astigmatism correction
- No lateral beam shift or beam deviation as with anamorphic prism pairs
- Various optics UV-IR
- Clear aperture: 6.5 mm



Form Factor

The anamorphic effect is described by the form factor F , which indicates the relative diameter change of the parallel beam.

The target value is calculated from the ratio of the beam diameters \varnothing_{\perp} and \varnothing_{\parallel} of the collimated beam.

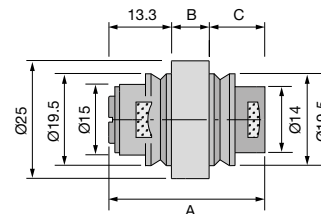
- Diffraction-limited optics pair
- $\varnothing 19.5$ mm system mount: Full integration with multicube™ system / 30 mm cage system, collimators and adapters

Technical Data

Dimensions			Form factor F	Wavelength range [nm] λ	Order Code
A	B	C			
26.8	8	5.5	0.63	600 - 1020	5 AN - 1.6 - 05
31.8	10	8.5	0.5	390 - 620	5 AN - 2 - 35
31.8	10	8.5	0.5	600 - 1020	5 AN - 2 - 05
31.8	10	8.5	0.5	980 - 1550	5 AN - 2 - 08
31.3	8	10	0.4	600 - 1020	5 AN - 2.5 - 05
31.3	8	10	0.4	980 - 1550	5 AN - 2.5 - 08
36.8	15	8.5	0.33	390 - 540	5 AN - 3 - 35
36.8	15	8.5	0.33	600 - 1020	5 AN - 3 - 05
36.8	15	8.5	0.33	980 - 1550	5 AN - 3 - 08
36.8	15	8.5	0.33	1500 - 2100	5 AN - 3 - 19

Dimensions

B Anamorphic beam-shaping optics type 5AN



Assembly and adjustment tools

- 1 Orientation and attachment of anamorphic beam-shaping optics to e.g. an adapter

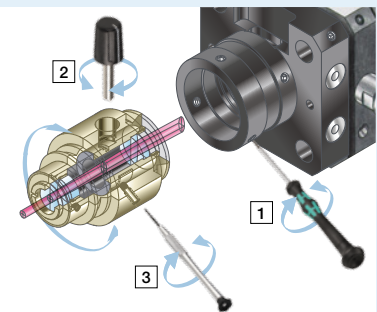
Tool: Hex screwdriver WS 1.5 mm **Order-Code** 50HD-15

- 2 Astigmatism correction by adjusting the optics pair

Tool: Eccentric key **Order-Code** 60EX-5

- 3 Locking of optics adjustment setting

Tool: Screwdriver WS 1.2 mm **Order-Code** 9D-12



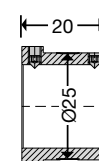
Order Options for Adapter 19.5AM25-L

Order Code 19.5AM25-L

The adapter 19.5AM25-L enables the 60SMF laser beam coupler to be positively and reproducibly locked into the beam-shaping optics.

Dimensions

D Adapter 19.5AM25-L



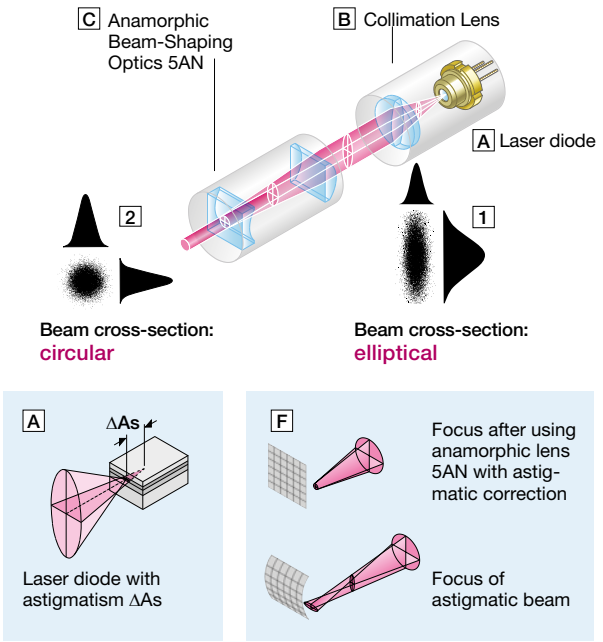
Laser diodes [A] have large aperture angles vertically (s) and smaller aperture angles in parallel (p) with the light-emitting layer. Additionally, some laser diodes have two virtual emission sources from the s - and p -directions, i.e. astigmatism, characterized by the axial displacement, ΔA_s .

The collimating lens [B] produces a collimated elliptical beam with a Gaussian intensity profile [1]. If there additionally is an astigmatic difference, ΔA_s , the beam is collimated in only one of the directions and is diverging in the other.

The anamorphic beam-shaping optics [C] contains a positive and a negative cylinder lens, scaling down the longer elliptical axis to that of the shorter axis. To compensate for divergence induced in the s -direction, the distance between the elements of the cylinder lens is increased (astigmatism correction).

The output beam profile [2] of the anamorphic beam-shaping optics is circular and the beam is collimated (if the anamorphic form factor is chosen correctly). After astigmatism correction, the wave fronts are planar.

When this beam is refocused, the spot is not only circular but also has plane wave fronts [F]. Without astigmatism correction (e.g. when beam shaping is performed using anamorphic prism optics), the focus shows astigmatism and the wave fronts are curved.



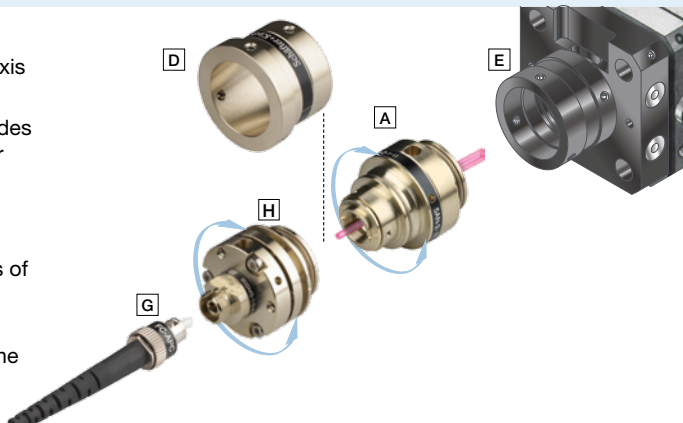
Beam-Shaping and Coupling into Single-Mode Fibers

The optically active axis of the anamorphic beam-shaping optics [A] is orientated in parallel with the longer elliptical axis of the collimated laser beam.

The circular V-groove at the anamorphic optics input provides a positive, rotatable and lockable connection with the laser diode collimator [E].

When coupling into polarization-maintaining fibers [G], the (slow) polarization axis of the fiber together the laser beam coupler [H] beam must be aligned with the polarization axis of the laser beam.

The alignment of the polarization axis is facilitated by the rotatable and lockable adapter flange 19.5AM25-L [D] on the output side of the anamorphic optics.

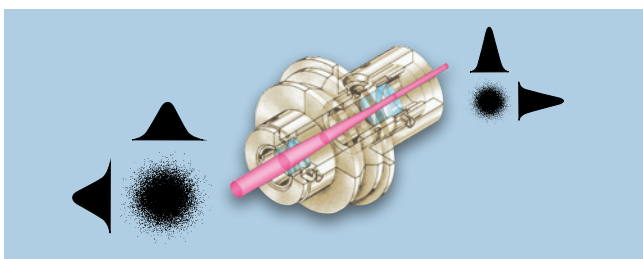


Expansion Optics Type 48EO

Expands the beam diameter of the collimated beam

The best fiber coupling efficiency for beam diameters < 0.4 mm is achieved when the laser beam is expanded in advance.

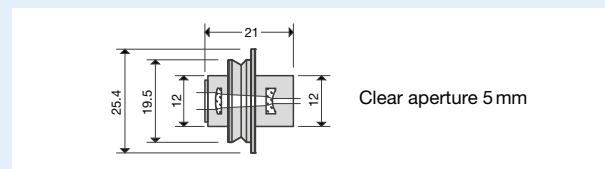
This is done using the Schäfter+Kirchhoff beam expander type 48EO allowing lenses of longer focal length to be used, which improves polarization extinction, makes adjustment easier and increases coupling efficiencies.



Order Options for Expansion Optics 48EO

Order Code	48EO - 3 - 26	
	3	Expansion factor
	26	Spectral range
		26 = 420 – 700 nm
		02 = 600 – 1050 nm

Dimensions



Fiber Cables

**Fiber Cables
single-mode,
polarization-maintaining,
and multimode**



PM



SM



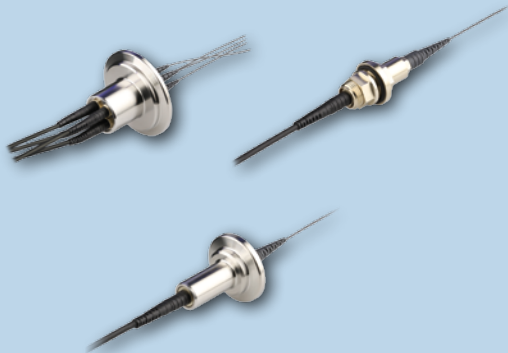
Multimode



Optional:
Fiber with
End Caps



Optional:
RGB



PCF



PCF-SM



Fiber Cables

Fibers Fundamentals	50
Fiber Connectors Fundamentals	52
Product Configurator	53
Polarization-Maintaining Fiber Cables PMC	54
Single-Mode Fiber Cables SMC	55
Multimode Fiber Cables MMC	56
Vacuum Feed-Throughs	58
Casing Feed-Throughs	59
PCF Broadband Fiber Cables	60
Bulkhead Adapters	61
Accessories	63

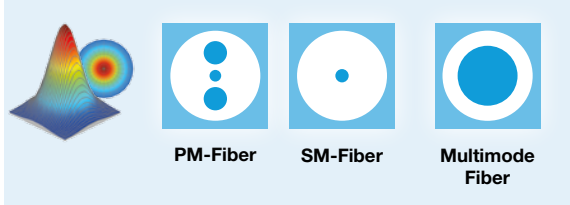


Technotes and Fundamentals

For more information, please refer to the extensive technotes section on: www.sukhamburg.com/support/technotes.html

1 Different Fiber Types:

Polarization-maintaining single-mode fiber (Standard: type PANDA); standard single-mode fiber; multimode fiber.



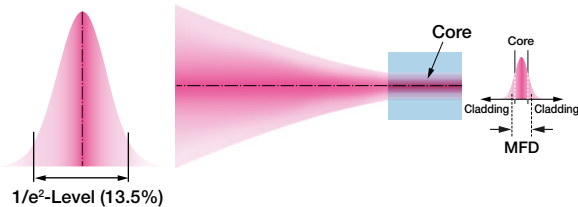
2 Effective Numerical Aperture NAe^2

For fiber-coupling purposes an effective fiber NAe^2 defined at the $1/e^2$ -level is more convenient than the nominal fiber NA defined by the refractive indices as Gaussian beams generally are defined by their $1/e^2$ diameter, also.

Schäfter+Kirchhoff defines an effective fiber NA which corresponds to the divergence of the power distribution emitted by the fiber taken at the $1/e^2$ -level of the Gaussian angle distribution.

This NA value is the designated effective numerical aperture NAe^2 . For a typical single-mode fiber the value is $NAe^2 = 0.075$.

For single-mode fibers and for polarization-maintaining fibers, the effective NAe^2 typically decreases slightly with increasing wavelength λ .



When purchasing a fiber from Schäfter+Kirchhoff, the fiber is delivered with more accurate measurements of the effective numerical aperture NAe^2 . Schäfter+Kirchhoff determines the NAe^2 of the fiber for each fiber batch by measuring the divergence of the emitted radiation in the far field. Due to the wavelength dependence of the NAe^2 , this is done for several typical wavelengths in the working range of the fiber.

3 Nominal Numerical Aperture

Schäfter+Kirchhoff obtain fibers from different manufacturers. The fiber manufacturers use the nominal numerical aperture NA of the fibers defined as

$$NA = \sqrt{n_{co}^2 - n_{cl}^2}$$

with n_{co} and n_{cl} as the refractive indices of fiber core and cladding, respectively.

For a typical single-mode or a polarization-maintaining fiber, the nominal value is $NA = 0.12$. This NA specification corresponds to the Gaussian angle distribution at a 1 - 5 %-level.

4 Cut-Off Wavelength

The cut-off wavelength λ_{co} is defined as the shortest wavelength for which the fiber is single-mode. The mode field can only have a Gaussian intensity distribution and rotational symmetry at wavelengths above λ_{co} .

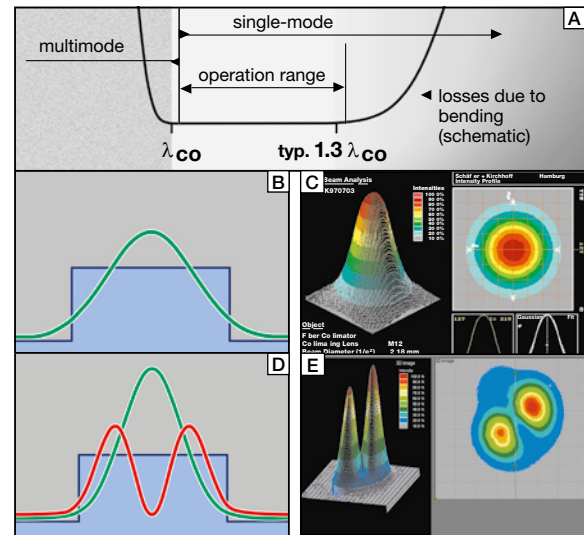
If the wavelength of the guided radiation is shorter than the cut-off wavelength, two or more modes are guided. The beam and intensity profile then differ significantly from a Gaussian distribution. The mode field distribution depends on bending or temperature variations (butterfly effect).

The wavelength range [A] in which the fiber can operate (operation range) depends on the fiber parameters and can reach 1.3 times λ_{co} . The operating wavelength range of fibers with a pure silica core is smaller.

If the wavelength is longer than 1.3 times λ_{co} , the guidance of the radiation becomes increasingly weaker. Even a slight bending of the fiber (as well as micro-bends) result in attenuation of the guided radiation (increased bending loss).

When more than one fiber can be used for a particular wavelength, the fiber with a cut-off wavelength closer to the operation wavelength should be chosen.

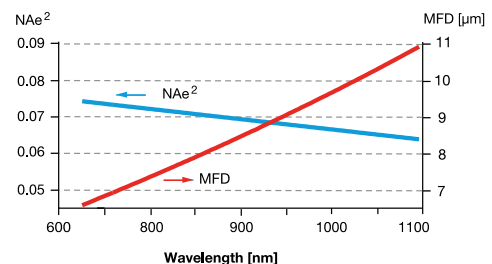
The measured cut-off wavelength λ_{co} of a fiber may be 10% less than the nominal value because of manufacturing tolerances. Carefully selected fibers with characterized values are available on request.



Operating range of a single-mode fiber [A] Gaussian Mode field of a single-mode fiber [B] and resulting Gaussian intensity distribution [C] at the fiber exit.

Fiber used below the cut-off wavelength (here 780 nm): At 633 nm the mode field shows multiple modes (butterfly effect) [D], which results in a non-Gaussian intensity distribution [E].

5 Wavelength Dependency of NAe^2 and MFD



Typical wavelength dependency: Effective numerical aperture NAe^2 (left scale) and mode field diameter MFD (right scale) as a function of the wavelength for a PMC-780 fiber.

6 Mode Field Diameter

The mode field diameter MFD is the diameter of the beam profile on exiting the single-mode fiber. The MFD depends on the wavelength and the effective numerical aperture NA_{eff} of the fiber according to:

$$MFD = \frac{2 \cdot \lambda}{\pi \cdot NA_{eff}}$$

Both the MFD, and the effective NA_{eff} are given at the 13.5% ($1/e^2$)-level of the Gaussian profile. For both, single-mode and polarization-maintaining fibers, the MFD is of the same magnitude as the core diameter.

When coupling high power levels, fibers with a larger MFD might be preferred. For fibers with a large MFD (small NA_{eff}), the power density within the fiber is reduced and the Brillouin threshold P_{cr} is increased.

Additionally, in order to prevent the damage of the fiber end faces, fiber connectors with end caps may be needed. For details see Box 13 (page 50).

7 Mismatch / NA Mismatch

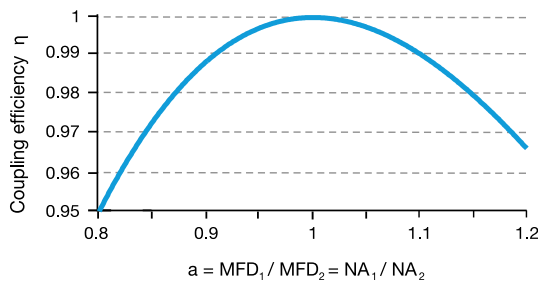
For both single-mode and polarization-maintaining fibers, the numerical aperture NA_{eff} and mode field diameter MFD may vary by up to 10% from the specified values, simply arising from manufacturing tolerances. Selected fibers with characterized values are available on request.

The theoretical coupling efficiency η (overlap integral between two Gaussian intensity distributions) is still close to $\eta = 1$ even when mode field diameter of an actual fiber differs from the theoretical value.

The linear relationship between mode field diameter MFD and numerical aperture NA_{eff} means that this is also valid for a mismatch in the values for NA_{eff} .

Example: $NA_{eff1} = 0.07$
 $NA_{eff2} = 0.08$

Overlap: $\eta = 0.982$



Overlap depending on MFD or NA

When coupling two fiber cables with

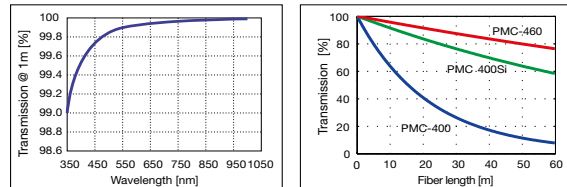
$$NA_{eff1} / NA_{eff2} = MFD_1 / MFD_2 < 0.6$$

then the Schäfter+Kirchhoff 60FF-T Fiber-Fiber coupler is recommended, see page 21.

8 Fiber Attenuation

The attenuation in fibers used for wavelengths below 1550 nm is dominated by Rayleigh scattering. For wavelengths below 600 nm, UV absorption becomes more relevant. The attenuation is approximately 1 dB/km for $\lambda = 1000$ nm. With decreasing wavelength, the attenuation increases to approximately 20 dB/km for $\lambda = 460$ nm and to approximately 40 dB/km for $\lambda = 400$ nm.

When using standard fibers at wavelengths below 460 nm, additional solarization effects worsen the attenuation further. Schäfter+Kirchhoff offer pure silica core fiber cables in order to increase fiber performance at lower wavelengths. (Details in Box 9)



Attenuation of single-mode and polarization-maintaining fibers depending on wavelength (left) and for different fiber types depending on fiber length (right)

9 Pure Silica Core Fibers (Si)

Single-mode and polarization-maintaining fibers have a core doped with germanium as standard. Short-wavelength radiation interacts with the germanium to produce color centers that cause a non-reversible attenuation of the fiber (solarization effect) that increases with time.

For wavelengths < 460 nm, Schäfter+Kirchhoff provides single-mode fibers and polarization-maintaining fibers with a pure silica core. These fibers do not demonstrate radiation-induced attenuation and so have a lower attenuation that is stable over time.

Pure silica core fibers are also more resistant to hard radiation than Ge-doped fibers.

10 Stimulated Brillouin Scattering/Brillouin Threshold

Stimulated Brillouin Scattering (SBS) is an effect that limits the maximum power that can be transmitted by the fiber. Unlike photo-contamination and direct scorching of the fiber end-face, which limit the power that can be transmitted at the fiber end-face (Details in Box 13), stimulated Brillouin scattering is a bulk medium effect.

The electro-magnetic wave propagating within the optical fiber is scattered by acoustical phonons that are caused by electrostriction. The acoustical phonons induce periodic changes in refractive index (elasto-optical effect) that serve as a Bragg grating, reflecting the incoming radiation. The wavelength of the reflected radiation (Stokes photon) is shifted towards higher wavelengths.

If the input power exceeds the Brillouin threshold P_{cr} , almost the entire radiation is reflected. The threshold is defined as:

$$P_{cr} = \frac{21 \cdot A_{eff}}{g_B \cdot L_{eff}}$$

$A_{eff} \sim (MFD)^2$ = effective core diameter

L_{eff} = effective cable length, dependent on fiber losses

g_B = gain coefficient of the Brillouin spectrum

The critical power is wavelength-dependent and influenced by other fiber parameters. The amount of power that can be transmitted by a particular fiber needs to be determined for each fiber individually.

11 Polarization-Maintaining Fibers

In polarization-maintaining single-mode fibers (PM fibers), the fiber symmetry is broken by integrating stress elements in the fiber cladding. The light is then guided in two perpendicular principle states of polarization with different propagation constants – the fast and the slow axis. The linear polarization of light coupled into one of these axes is maintained. If light is guided partly in the other axis then the resulting polarization is elliptical (if the coherence length of the source is larger than the phase difference). Strain and temperature variations, however, change this arbitrary elliptical state. Thus it is important to exactly align the polarization axis of the laser source with the polarization axis of the fiber. The linearly polarized laser radiation is conventionally coupled into the slow axis because of its lower sensitivity to fiber bending.

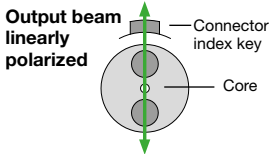
Different types of polarization-maintaining fibers are designed depending on the geometry of the stress elements: "PANDA" fibers, "Bow-Tie" fibers or "Oval-Inner Clad" fibers.

The polarization-maintaining fiber cables made by Schäfter+Kirchhoff typically use fibers of type PANDA. The slow axis is aligned with the index key of the FC type fiber connector with high precision ($<1.5^\circ$), see Box 12. The fiber cables made by Schäfter+Kirchhoff typically have a polarization extinction $>200:1$ (23 dB) or $>400:1$ (26 dB) for $\lambda > 780$ nm.

12 Alignment

A Good Alignment:

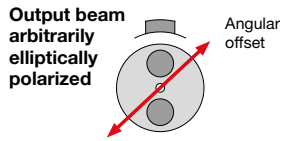
Connector key axis = slow axis = laser polarization axis



Axis orientation of a polarization-maintaining fiber with the connector key

B Bad Alignment:

Connector key axis and slow axis \neq laser polarization axis

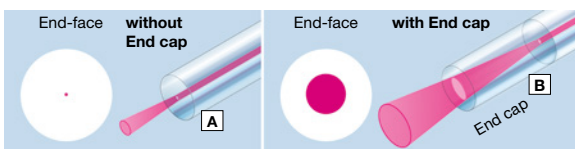


13 Fiber Connectors with End Caps

The maximum power that can be guided within a fiber is mainly restricted by the power density at the fiber end-faces, when not considering bulk, nonlinear optical effects within the fiber, such as Brillouin scattering (see Box 10). Extreme power densities can cause scorching of the end-face or photo-contamination by the generation of a dipole trap. These detrimental effects can be obviated using a fiber end cap, in which a short length of fiber ($<300 \mu\text{m}$) without a core is spliced onto the polarization-maintaining fiber [B].

Without a fiber core to confine the beam, the mode field diameter of the beam already starts to diverge within the fiber end cap and the resulting beam area at the end-face is significantly larger. The numerical aperture of a fiber is not affected by an end cap.

For 100 mW laser coupled into typical fibers, the power density at the end-face without an end cap [A] reaches multiple kW/mm², where as it is only hundreds of W/mm² with an end cap.



Using end caps is advisable for $\lambda \leq 532$ nm.

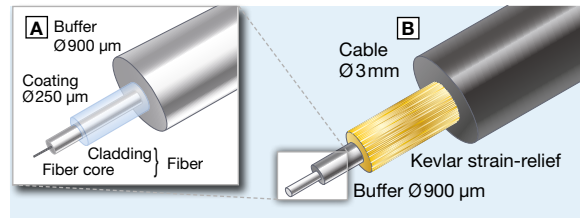
Working with End Cap Fibers

The end cap fibers are terminated with standard FC-connectors and profit from all benefits known for these standard connectors. Also, this means, that the fibers can then be used with 60SMF laser beam couplers or with 60FC fiber collimators for example, all of which have an easily and precisely adjustable focus position. This is of great importance when swapping a fiber without end cap for one with end caps, since in this case the focus position of the lens within the collimator or coupler has to be adjusted typically $<200 \mu\text{m}$ to correct for the divergence within the end cap.

14 Fiber Cable Types

Single-mode fiber cables made by Schäfter+Kirchhoff are either supplied with a $\varnothing 900 \mu\text{m}$ buffer and $\varnothing 3$ mm cable with Kevlar strain-relief [B] or with a $\varnothing 900 \mu\text{m}$ buffer [A] only. Both the cable and the buffering are black.

Fibers without buffer (with only the $\varnothing 250 \mu\text{m}$ coating) can be supplied on request.

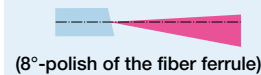


900 μm buffer cable [A] or 3 mm cable [B]

15 Fiber Cable with Connectors of Type FC

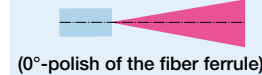
Schäfter+ Kirchhoff supplies fiber cables with two different FC-standards: FC-APC and FC-PC.

FC-APC connector



(8°-polish of the fiber ferrule)

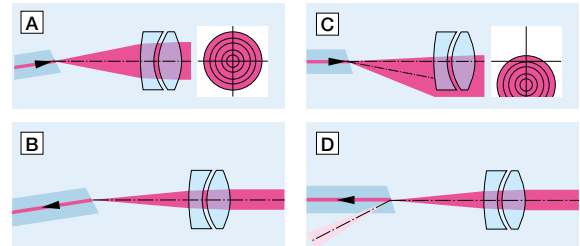
FC-PC connector



(0°-polish of the fiber ferrule)

Beam path for fibers with FC-APC and FC-PC connectors

In order to avoid back-reflection directly into the laser source, the fiber in the ferrule of the type FC-APC connector has an 8°-polished end-face. For fiber cables with this type of connector, Schäfter+Kirchhoff provides fiber collimators [A] and laser beam couplers [B] with an inclined coupling axis. If a fiber collimator with coaxial coupling axis is used with FC-APC type connectors then the beam is obstructed and its profile is distorted [C]. Equally, if a laser beam coupler [D] with coaxial coupling axis is used with FC-APC connectors then the coupling is reduced by about 50%.



Matching Components

Collimation [A] and fiber-coupling using couplers with inclined coupling axis. Mismatching collimator [C] and coupler [D].

Component Mismatch

An inclined connector/coupler is preferred in most cases.






16 Connector Options

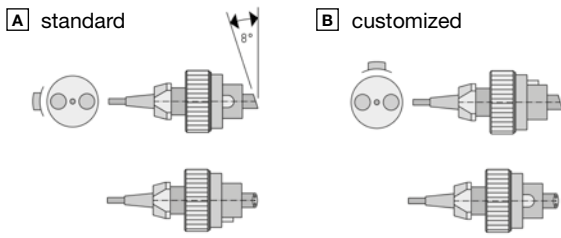
Single-mode fiber cables made by Schäfter+Kirchhoff are equipped with fiber connectors of type FC-APC or FC-PC. Optionally, they can be provided with fiber connectors of type ST, AVIM (comp. with LSA), F-SMA, E2000 or with different types of fiber connector at each end. An overview is provided in Table 1.

All of the fiber connectors of type FC assembled by Schäfter+Kirchhoff have an alignment index (key) of 2.14 mm standard width (or optionally of 2 mm, type "R").

For fiber connectors of type FC-APC, the connector key is orientated with the 8°-angled polish as shown in [A]. (Other orientations can be specified, such as that shown in [B]).

Table 1 Connector Types offered by Schäfter+Kirchhoff

Type	SM-fiber	PM-fiber	MM-fiber	PC/APC	option amag. (titanium)	option end cap	lock	Remarks
 FC	x	x	x	x/x	x	x	Screw	standard
 ST	x		x	x/-			Bayonet	
 AVIM	x	x	x	x/x			Screw	comp. with LSA
 F-SMA	x		x	x/-			Screw	
 E2000	x	x	x	x/x			Snap	



Orientation of the 8°- polish and index key for fiber connectors of type FC-APC:

[A] standard, [B] optional customized orientation (FCP8).

17 Amagnetic fiber connectors

Schäfter+Kirchhoff also offers amagnetic FC-APC and FC-PC fiber connectors completely made of titanium and with a ceramic ferrule. This ensures that the relative permeability μ_r of the connector is near 1 ($\chi = 5 \cdot 10^{-5}$, $\mu_r = 1.00005$), making it transparent to magnetic fields. Such highly defined magnetic fields are used for example in Electron Spin Resonance (ESR) or Nuclear Magnetic Resonance (NMR) experiments.

Another application of amagnetic fiber connectors is the highly precise measurement of a magnetic field (magnetometer) where perturbation of the magnetic field by magnetic materials close to the setup is undesirable. Other amagnetic components are also available, e.g. laser beam coupler (p.18) or collimators type 60FC (p. 25).

18 Core Alignment

Because of manufacturing tolerances, fiber connectors may have a misalignment of mechanical and optical axes. Schäfter+Kirchhoff single-mode fiber cables SMC (non-polarization-maintaining) can be provided with core alignment (offset $\leq 0.5 \mu\text{m}$).

The connector 60C-FC/FC ensures the direct connection of two fiber connectors using core alignment and a low coupling loss (see page 60).

Core alignment is not possible with polarization-maintaining fiber cables. When coupling two polarization-maintaining fiber cables then the Schäfter+ Kirchhoff 60FF-T Fiber-Fiber coupler is recommended (see p. 24).

19 RGB Fibers

RGB fibers have a pure silica core fiber with a cut off below a wavelength of 400 nm and are suitable for wavelengths up to 680 nm. However, at long wavelength this fiber is quite sensitive to disturbances, such as bending or stress.

The fiber cables of type PMC-400RGB are actually based on the same fiber type as the fiber cables of type PMC-400Si. (Same for SMC-400RGB and SMC-400Si).

During the manufacturing process of fiber cables of type RGB additional measures are taken to guarantee a high performance even at high wavelengths. Additional tests are performed to document that the fiber performance is high over the whole wavelength range.


Product Configurator – Selection Criteria for Fiber Cables



Fast and easy Selection using the Product Configurator

<https://www.sukhamburg.com/products/fiberoptics/fibers.html>

1. Decide the fiber type (single-mode, polarization-maintaining single-mode)
2. Determine the operation wavelength or wavelength range and chose adequate fibers accordingly. When more than one fiber can be used for a particular wavelength, choose the fiber with a cut-off wavelength closer to the operation wavelength/lower limit of the wavelength range
3. Special features: When an extra low attenuation is necessary, choose a pure Sililca fiber.
4. Special features: Select a fiber with small NA (larger MFD) for applications using higher powers
5. Select a cable type (900 μm Buffer cable or 3mm cable) and length
6. Select a fiber connector. An inclined connector should be preferred in most cases.
7. Using connectors with end caps is advisable for $\lambda \leq 532\text{nm}$.

Detailed data sheets, up-to-date technical information, technical drawings including step files, accessories, extensive technotes section and FAQs:
 www.sukhamburg.com

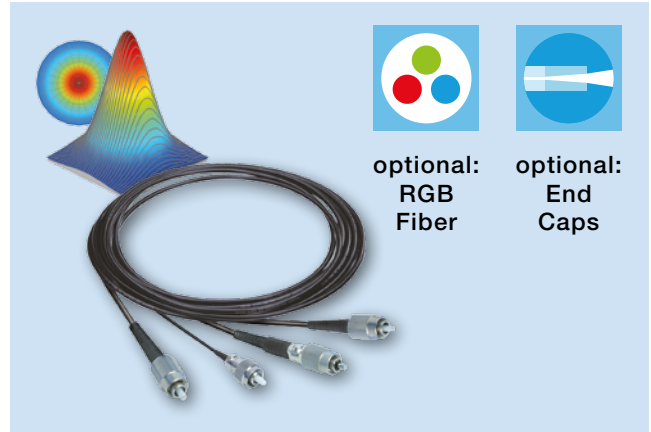
Polarization-Maintaining Single-Mode Fiber Cables PMC

Polarization-maintaining, single-mode fiber cable with Gaussian intensity distribution and low-stress fiber connectors



PM-Fiber

- Cut-off wavelengths from 360 nm to 1550 nm
- Wavelengths covering altogether 360 nm to 1800 nm – each fiber with an operational wavelength range of about 100-300 nm.
- Special broadband fiber RGB with an operational wavelength range 400-680 nm
- Pure Silica core fibers (Si) with low attenuation for wavelengths < 460 nm
- Measured values for fiber NA: NAe^2
- Special fibers with small NA for smaller power density in the fiber core
- Fiber patch cable with \varnothing 900 μ m buffer or as \varnothing 3 mm Cable with Kevlar strain-relief
- Customer-specified connectors type FC-APC (standard) FC PC, AVIM (comp. to LSA) or E2000 with 0°-polish or 8°-polish
- Polarization axis is indicated by connector index key (slow axis), only for Type FC connectors
- Amagnetic titanium connectors for connectors of type FC PC or FC APC, p. 53
- End caps for a smaller power density at the fiber end-faces, p.52



optional:
RGB
Fiber


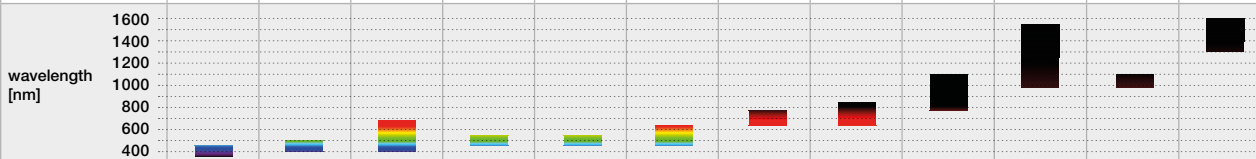
optional:
End
Caps

Quick and efficient product selection
with the Product Configurator:
www.sukhamburg.com



The three defining parameters of a polarization-maintaining single-mode fiber are effective numerical aperture NAe^2 , mode field diameter MFD and cut-off wavelength λ_{co} . Because of manufacturing tolerances, the mean specified values for NAe^2 and MFD may differ by up to 10%.

Using fibers with end caps reduces the risk of damaging the fiber end face, by reducing the power density but without changing the numerical aperture NA of the fiber.


row		1	2		4	5	6	7	8	9	10	11	12
1	Fiber Type PMC-	360 Si	400 Si	400 RGB	460 Si	460 Si-L	460	630 Si	630	780	980	980-L	1300
2	Nom. wavelength λ_{nom}	360	400	400	460	460	460	630	630	780	980	980	1300
3	NA nominal	NA 0.12	NA 0.11	NA 0.11	NA 0.12	NA 0.09	NA 0.12	NA 0.12	NA 0.12	NA 0.12	NA 0.12	NA 0.085	NA 0.11
4	Cut-off wavelength λ_{co}	< 360	< 400	< 400	< 460	< 460	< 460	< 620	< 620	< 770	< 970	< 980	< 1300
5	Op. wavelength range	360-460	400-500	400-680	460-550	460-550	450-630	620-780	620-850	770-1100	970-1550	980-1100	1300-1625
6	MFD nom.	2.3	3.5	3.5	3.5	4.0	3.3	4.2	4.5	5.3	8.0	10.5	9.3
7	Eff. Numerical Aperture NAe^2 (typ.)*	0.079-0.071	0.071-0.063	0.071-0.046	0.087-0.079	0.062-0.060	0.081-0.057	0.092-0.086	0.079-0.065	0.078-0.067	0.081-0.068	0.058-0.056	
8	MFD [μ m]**	2.9-4.1	3.6-5.1	3.6-9.2	3.4-4.4	4.7-5.8	3.6-7.0	4.3-5.8	5.0-8.3	6.3-10.5	7.7-14.5	10.8-12.5	
9	Large MFD					X						X	
10	Pure Silica core	X	X	X	X	X		X					
11	End caps***	X	X	X	X	X	X	optional		optional		optional	optional
12	wavelength [nm]												

All fibers are specified with the measured values for the effective NAe^2 . The NA of the fiber is given by the manufacturer. Plots $NAe^2(\lambda)$ see www.sukhamburg.com.

* Effective fiber NAe^2 definition see p. 50
No/one value only; resp. NAe^2 value has not been measured yet.

** Calculated from the NAe^2 and the wavelength λ .

*** Using end caps is advisable for $\lambda \leq 532$ nm.

 RGB fiber suitable for the entire visible wavelength range of 400 - 680 nm. Additional measures are taken to guarantee a high performance even at high wavelengths. Apochromatically corrected couplers see p. 17/23

Order Options for PM Single-Mode Fiber Cables

Order Code **PMC - 780 - 3 - 18/20E-150**

PMC = polarization-maintaining, single-mode fiber cable

Fiber Type (row 1) including:

- Si Pure Silica core
- RGB broad band fibers 400- 680 nm
- L low NA fibers (large MFD)
- H high NA fibers, all if stated

Cable type:

- 3 = \varnothing 3 mm cable with Kevlar strain-relief, **standard** (no connectors with special feature V)
- 1 = fiber cable with \varnothing 0.9 mm buffer

Length in cm (standard = 150)

18/20E 1st fiber end / 2nd fiber end: Connector Codes

1st connector Type (mandatory):

- 1 FC wide key (type 'N' 2.14 mm), **standard**
- 2 FC narrow key (type 'R' 2 mm)
- 6 E2000, no special features E, T, V
- 7 AVIM (comp. to LSA), no special features E, T, V

1st fiber end polish (mandatory):

- 0 PC (0°-polish)
- 8 APC (8°-polish), **standard**

1st special features (optional):

- E connector with end cap
- T amagnetic connector made from titanium
- V vacuum-compatible connector

Insert "/" and repeat for 2nd fiber end

Note: Only one Connector Code means identical connector choices for both fiber ends!

Example: 18/20E: 1st fiber connector of type FC-APC (8°-polish), „wide key“; 2nd fiber connector of type FC-PC (0°-polish), „narrow key“ and end cap.

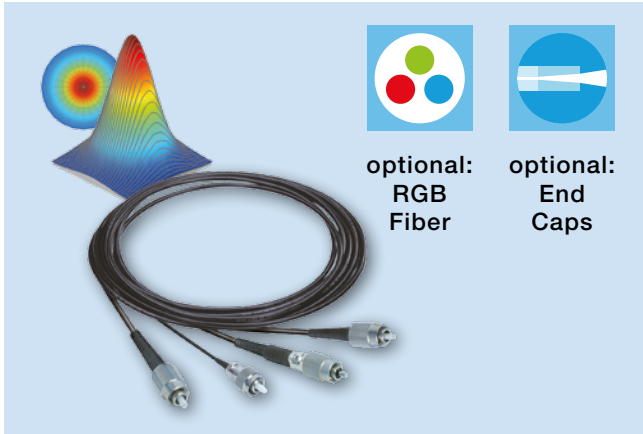
Single-Mode Fiber Cables SMC

Single-mode fiber cable with Gaussian intensity distribution and low-stress fiber connectors.



SM-Fiber

- Cut-off wavelengths from 360 nm to 1300 nm
- Wavelengths covering altogether 360nm to 1650 nm - each fiber with an operational wavelength range of about 100-300 nm.
- Special broadband fiber RGB with an operational wavelength range 400-680 nm
- Pure Silica core fibers with low attenuation for wavelengths < 460 nm
- Measured values for fiber NA: NAe^2
- Special fibers with small NA for smaller power density in the fiber core
- Fiber patch cable available with \varnothing 900 μ m buffer or as \varnothing 3 mm Cable with Kevlar strain-relief
- Customer-specified connectors type FC, DIN or AVIM (comp. to LSA), E2000, ST (only 0°-polish), or F-SMA (only 0°-polish) with 0°-polish or 8°-polish
- Amagnetic titanium connectors for connectors of type FC PC or FC APC, p. 53
- End caps for a smaller power density at the fiber end-faces, p.52
- Option: core-centered



optional: RGB Fiber



optional: End Caps

Quick and efficient product selection with the Product Configurator: www.sukhamburg.com



The three defining parameters of a single-mode fiber are effective numerical aperture NAe^2 , mode field diameter MFD and cut-off wavelength λ_{co} . Because of manufacturing tolerances, the mean specified values for NAe^2 and MFD may differ by up to 10%. Carefully selected fibers with documented values are available on request. Fiber cables with end caps are available.

Please note that unlike the PMC-fiber cables on page 52 single-mode fibers in general do not maintain the state of polarization.

Table 2 Single-Mode Fiber Cables Type SMC (Partial selection only. More on www.sukhamburg.com)

row		1	2		4	5	6	7	8	9	10	11
1	Fiber Type SMC-	360 Si	400 Si	400 Si	460	460 Si	530	630	630 Si	780	980	1300
2	Nom. wavelength λ_{nom}	360	400	400	460	460	530	630	630	780	980	1300
3	NA nominal	NA 0.13	NA 0.12	NA 0.12	NA 0.13	NA 0.12	NA 0.11	NA 0.13	NA 0.12	NA 0.13	NA 0.14	NA 0.14
4	Cut-off wavelength λ_{co}	< 360	< 400	< 400	< 460	< 460	< 530	< 630	< 620	< 780	< 980	< 1300
5	Op. wavelength range	360-430	400-550	400-680	400-600	450-600	530-700	600-770	620-860	760-970	970-1550	1260-1700
6	MFD nom.	2.3	3.3	3.3	3.5	3.4	3.5	4.0	4.2	5.0	5.9	10.4
7	Eff. Numerical Aperture NAe^2 (typ.)*	0.095-0.086	0.072-0.059	0.072-0.047	0.089-0.070	0.081-0.072	0.095-0.08	0.085-0.074	0.082	0.092-0.082	0.093-0.074	0.082-0.079
8	MFD [μ m]**	2.4-3.2	3.5-5.9	3.5-9.2	2.9-5.5	3.5-5.4	3.5-6.3	4.5-6.6	4.8	5.3-7.5	6.6-13.3	9.8-13.7
9												
10	Pure Silica core	X	X	X		X			X			
11	End caps***	X	X	X	X	X			optional	optional	optional	optional
12	wavelength [nm]											

All fibers are specified with the measured values for the effective NAe^2 . The NA of the fiber is given by the manufacturer. Plots $NAe^2(\lambda)$ see www.sukhamburg.com.

- * Effective fiber NAe^2 definition see p. 50
- No/one value only: resp. NAe^2 value has not been measured yet.
- ** Calculated from the NAe^2 and the wavelength λ .
- *** Using end caps is advisable for $\lambda \leq 532$ nm



RGB fiber suitable for the entire visible wavelength range of 400 - 680 nm. Additional measures are taken to guarantee a high performance even at high wavelengths. Apochromatically corrected couplers see p. 17/23

Order Options for Single-Mode Fiber Cables

Order Code SMC - 780 - 3 - 18EV/18TE-150

SMC = single-mode fiber cable

Length in cm (standard = 150)

28EV/10TE 1st fiber end / 2nd fiber end: Connector Codes

1st connector Type (mandatory):

- 1 FC wide key (type 'N' 2.14 mm), **standard**
- 2 FC narrow key (type 'R' 2 mm)
- 6 E2000, no special features E, T, V
- 7 AVIM (comp. to LSA), no special features E, T, V, C

1st fiber end polish (mandatory):

- 0 PC (0°-polish)
- 8 APC (8°-polish), **standard**

1st special features (optional):

- E connector with end cap (no spec. feat. C)
- T amagnetic connect. made from titanium (no spec. feat. C)
- V vacuum-compatible connector (no spec. feat. C)
- C core-centered (no spec. feat. E, T, V)

Insert "/" and repeat for 2nd fiber end

Note: Only one Connector Code means identical connector choices for both fiber ends!

Fiber Type (row 1) including:

- Si Pure Silica core
- RGB broad band fibers 400- 680 nm
- L low NA fibers (large MFD)
- H high NA fibers

Cable type:

- 3 = \varnothing 3 mm cable with Kevlar strain-relief, **standard** (no connectors with special feature V)
- 1 = fiber cable with \varnothing 0.9 mm buffer

Example: 18EV/18TE: 1st fiber connector of type FC-APC (8°-polish), 'wide key', vacuum-compatible and with end cap; 2nd fiber connector of type FC-APC (8°-polish), 'wide key', amagnetic with end cap.

Multimode Fiber Cables Type MMC



Multimode Fiber

- Multimode
- High OH⁻ for UV and VIS transmission and Low OH⁻ for VIS and NIR radiation
- FC-APC or FC-PC fiber connector (other connector types available on request)
- Amagnetic titanium connectors available for FC-APC or FC-PC connectors (for details see page 53)
- Use for vacuum feed-throughs
- Black cable/black buffer available



Table 3 Multimode Fiber Cables Type MMC G = Gradient-index fiber / S = Step-index fiber

row	curr. no	1	2	3	4	5	6	7	8	9
1	Fiber Type	G	S	S	S	S	S	S	S	S
2	Core diameter [µm]	62.5	50	50	105	105	200	200	300	300
3	Num. aperture NA	0.27	0.22	0.22	0.22	0.22	0.22	0.22	0.22	0.22
4	UV/VIS (High OH ⁻)		x		x		x		x	
5	VIS/NIR (Low OH ⁻)	x		x		x		x		x
6	Suitable for vacuum feed-throughs V-...	x	x	x	x	x	x	x		

The MM fibers listed in Table 4 are a small selection of available fibers. Please contact Schäfter+Kirchhoff if the required specifications are not listed. By careful selection, it is possible for Schäfter+Kirchhoff to offer fibers with defined properties that can differ from those specified by the manufacturer.

Please note that the beam profile emitted by a multimode fiber is not Gaussian. Fiber-fiber coupling from a multimode to a single-mode fiber is non-functioning.

Order Options for Multimode Fiber Cables MMC

Order Code **MMC - S - VIS/NIR - 50 - NA022 - 3 - 28 - 150**

MMC = Multimode fiber cable Length in cm (standard = 150)

MMC fiber type:
 S = Step index
 G = Gradient index

Wavelength range:
 UV/VIS = High OH⁻, for UV or VIS radiation
 VIS/NIR = Low OH⁻, for VIS or NIR radiation

Core Diameter
 Numerical aperture NA

Cable type:
 3 = Ø 3 mm cable with Kevlar strain-relief, **standard** (no connectors with special feature V)
 1 = fiber cable with Ø 0.9 mm buffer

Connector Code

1st connector Type (mandatory):
 1 FC wide key (type 'N' 2.14 mm), **standard**
 2 FC narrow key (type 'R' 2 mm)
 3 F-SMA (PC, 0°-polish only)
 6 E2000, (no special features T, V)
 7 AVIM (comp. to LSA), (no special features T, V)

1st fiber end polish (mandatory):
 0 PC (0°-polish)
 8 APC (8°-polish), **standard**

1st special features (optional):
 T amagnetic connector made from titanium (only for fibers No. 1-5)
 V vacuum-compatible connector

Insert "/" and repeat for 2nd fiber end

Note: Only one Connector Code means identical connector choices for both fiber ends!

How to find the adequate Fiber Collimator

Finding Fiber Collimators for Multimode Fiber Cables – the Product Configurator



Fast and easy selection of fiber couplers and collimators on www.sukhamburg.com

The new product configurator for fiber couplers and collimators, helps select products based on a number of technical specifications and narrows down the search to a few relevant products that meet the customer's need.

Simply select „Use with multimode fibers“ and the Product Configurator will only show suitable options.

Other features include:

- Sliders/check boxes for different parameters like e.g wavelength (range), focal length or input/collimated beam diameter etc.
- Integrated calculator of dependent parameters like focal length, collimated beam diameter, Rayleigh range and beam divergence
- Special features like UHV compatibility, material and housing options

Technical details can be compared 1:1 by using the product comparison function.

The detailed specific product pages include:

- Detailed description, up-to-date technical data, technical drawings including step files (step files for registered users only), adequate accessories including tools, adapters etc., extensive technotes section, FAQs

The data on the website is updated frequently. If you want the latest information on our fiber couplers and collimators, please refer to www.sukhamburg.com/fiberoptics.html

Related Product: Fiber Couplers 60FC-A19.5

for coupling into multimode fiber cables

Fiber coupler (fiber port) with system mount Ø 19.5 mm for multimode fiber coupling. For details see page 44.

- For multimode fiber cables or applications that do not require TILT adjustment
- System mount Ø 19.5 mm, fits directly into the multicube™ system
- Integrated focusing adjustment
- Focal lengths up to 18 mm
- Choice of aspheres, monochromats, achromats and apochromats
- Various AR coatings for UV - IR
- Choice of fiber receptacles: FC PC or FC APC (standard), many others available



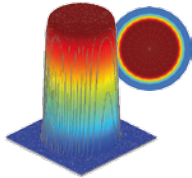
Quick and efficient product selection with the Product Configurator:
www.sukhamburg.com



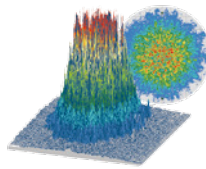
Intensity Profile of Multimode Fibers

The intensity profile of a multimode fiber strongly depends on the type of radiation input.

For coherent light sources, the intensity profile exhibits speckle that arise due to interference between the multiple modes.



Low coherent light source



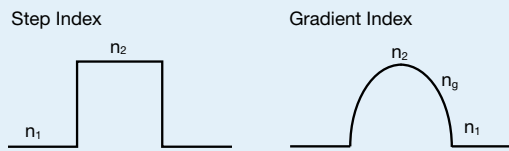
Coherent light source

Gradient index vs. step index in Multimode Fibers

While common single-mode fibers have a step-index profile for the refractive index, there are two types of multimode fibers: step-index and gradient-index.

Step-index fibers have a step profile with one refractive index n_2 for the core and one for cladding (refractive index n_1) throughout the fiber. The core diameter of a multimode fiber is rather large ($>50\mu\text{m}$), allowing multiple modes of light guidance.

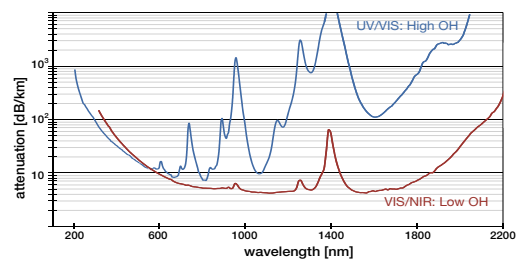
A gradient-index fiber exhibits a gradual profile (almost parabolic in shape) for the refractive index, which results in a smaller modal dispersion because of the approximately sinusoidal beam propagation along the fiber.



Typical Spectra for UV/VIS or VIS/NIR Multimode Fiber Cables

OH⁻ groups cause attenuation at IR wavelengths however a beneficial for UV transmission.

Most of the multimode fibers from Schäfer+Kirchhoff are offered in a UV/VIS and in a VIS/NIR version.



Collimating the beam

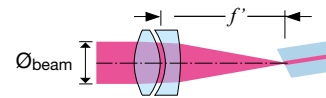
The beam diameter $\varnothing_{\text{Beam}}$ is given by the focal length of the collimating lens f' and by the numerical aperture NA of the multimode fiber.

$$\varnothing_{\text{Beam}} = 2f' \cdot NA$$

The beam always shows divergence due to the finite core diameter d . The divergence angle ϑ is defined as:

$$\vartheta \approx d/2f'$$

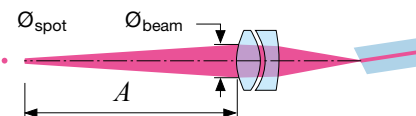
It is important that the numerical aperture of the chosen lens is higher than the numerical aperture of the multimode fiber. Table 5 shows some appropriate collimating lenses.



Focused laser beam

The collimating lens can be adjusted to generate a focused beam. At distance A , relative to the fiber collimator, a beam waist with diameter $\varnothing_{\text{spot}}$ is formed.

$$\varnothing_{\text{spot}} = \varnothing \left(\frac{A}{f'} + 1 \right)$$



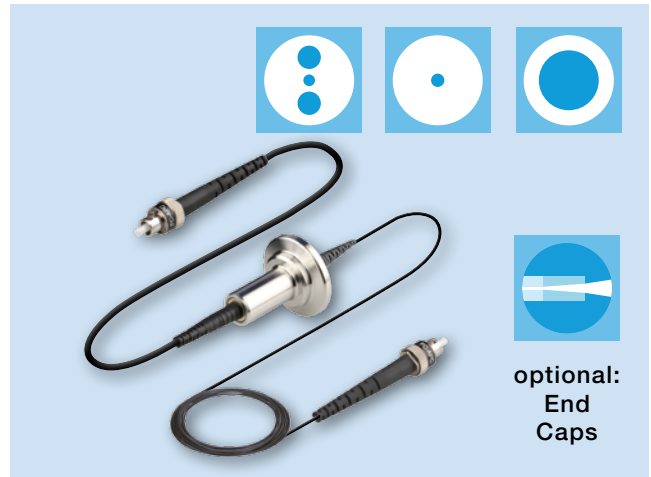
$\varnothing_{\text{spot}}$: Beam diameter in focus
 A : Working distance
 f' : Focal length of collimating lens

Vacuum Feed-Throughs

with single-mode, polarization-maintaining or multimode fiber cables

All vacuum feed-throughs by Schäfter+Kirchhoff are supplied with a non-exchangable, continuous, end-to-end fiber cable. That means there is no additional fiber connection (mating) at the vacuum flange. The benefit is no additional coupling losses due to mating (especially important for transmitting short wavelengths) and for PM fibers no reduction in Polarization Extinction Ratio (PER)

- Single feed-throughs V-SF with screw-type flange M12 x 0.75 mm (copper alloy), V-KF16 with small flange KF16 (stainless steel) or small flange KF50 (stainless steel)
- Multiple feed-throughs with flange type KF40 (1, 2, 3 or 4 fiber cables) or KF50 with (1, 2, 3 or 4 fiber cables), combination of arbitrary fiber cable types possible
- Suitable for vacuums down to 10^{-7} mbar
- Integrated single-mode, polarization-maintaining or multimode fiber cable (cut-off wavelengths 360 nm - 1800 nm, see p. 52ff)
- Vacuum side: fiber cable with \varnothing 900 μ m buffer (TPE-E)
- Outside the vacuum: \varnothing 3 mm fiber cable with Kevlar strain-relief with bend protection both at the fiber connector and the flange.
- Different connector types including optional end caps (see p. 52) and amagnetic connectors (see p. 53)



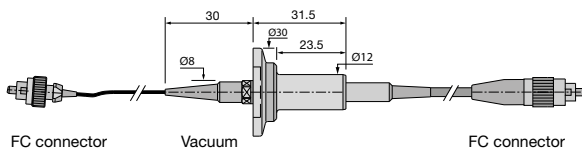
optional:
End Caps

Detailed data sheets, up-to-date technical information, technical drawings including step files, accessories, extensive technotes section and FAQs:
www.sukhamburg.com

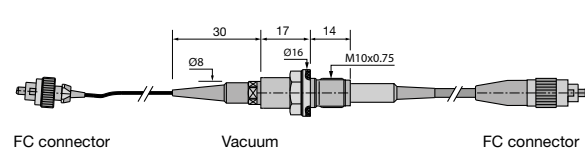


Dimensions: Single Feed-Through

Small flange KF16 (DIN 28403)

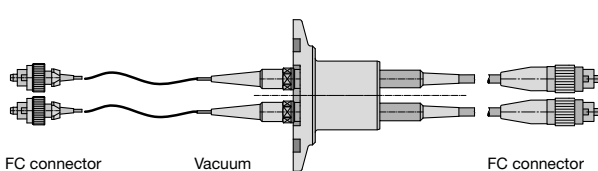


Screw-type flange (M12 x 1 mm)

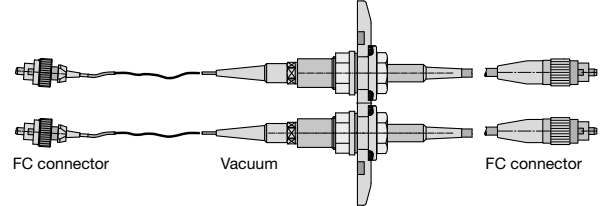


Dimensions: Multiple Cable Feed-Throughs

Flange type KF40 available with 1, 2, 3, or 4 fiber cables of arbitrary type



Flange type KF50 available with 1, 2, 3, or 4 fiber cables of arbitrary type



Order Options for Vacuum Feed-throughs (For fiber specifications, please see p. 52ff.)

Order Code V-SF - PMC - 780 - 28ET/20E - 30/120

Flange type:
 V-KF16 = Vacuum feed-through with small flange KF16 (optional: KF40, KF50)
 V-SF = Vacuum feed-through with screw flange M12x1mm

Fiber:
 SMC = single-mode fiber cable
 PMC = polarization-maintaining fiber cable
 MMC = multimode fiber cable

Fiber Type (row 1) including:
 Single-mode/PM: Nominal cut off wavelength, and Si (Pure Silica core), RGB (broad band fibers 400 - 680 nm), L (low NA fibers, large MFD) or H (high NA fibers), when stated

Multimode: Core type:
 S (Step index) or G (Gradient index), add "-"
 Wavelength range: UV/VIS or VIS/NIR, add "-"
 Core diameter, add "-"
 Numerical aperture NA

Cable length in cm (in = vacuum side / out)
 Note: Only one cable length means identical lengths for in and out!
 18ET / 20E Fiber connectors (in / out) Connector Codes

1st connector Type (mandatory):
 1 FC wide key (type 'N' 2.14 mm), **standard**
 2 FC narrow key (type 'R' 2 mm)
 3 F-SMA (PC, 0°-polish only), multimode only
 6 E2000, out only, no special features E, T
 7 AVIM (comp. to LSA), out only, no special features E, T

1st fiber end polish (mandatory):
 0 PC (0°-polish)
 8 APC (8°-polish), **standard**

1st special features (optional):
 E with end cap (single-mode/PM only, no spec. feat. C)
 T amagnetic (titanium), (no spec. feat. C)
 C core-centered (single-mode only, out only, no spec. feat. E, T)

Insert "/" and repeat for 2nd fiber end
 Note: Only one Connector Code means identical connector choices for both fiber ends!

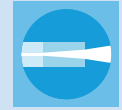
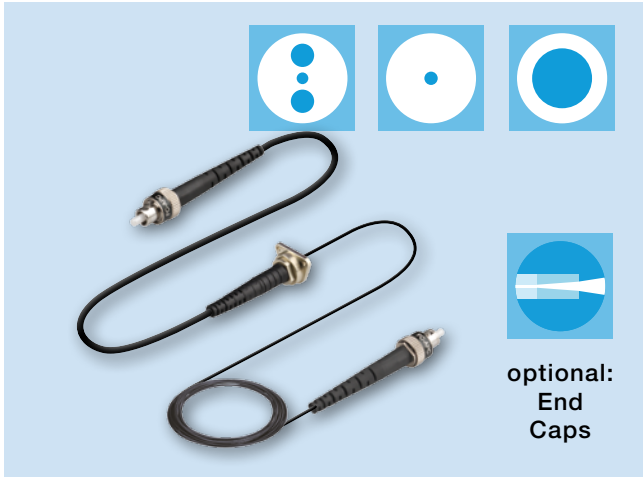
Example: 18ET/20E: 1st fiber connector (in) of type FC-APC (8°-polish), 'wide key', amagnetic with end cap; 2nd fiber connector (out) of type FC-PC (0°-polish), 'wide key', with end cap.

Casing Feed-Throughs

with single-mode, polarization-maintaining or multimode fiber cables

All casing feed-throughs type CFT by Schäfter+Kirchhoff are supplied with a non-exchangable, continuous, end-to-end fiber cable. That means there is no additional fiber connection (mating) at the flange. The benefit is no additional coupling losses due to mating (especially important for transmitting short wavelengths) and for PM fibers no reduction in Polarization Extinction Ratio (PER). The casing feed-throughs are installed by threading the outer part of the fiber cable from the inside of the casing through the through hole.

- For through hole Ø 10.7 mm
- Integrated single-mode, polarization-maintaining or multimode fiber cable (cut-off wavelengths 360 nm - 1800 nm, see p. 52ff)
- Inside the casing: fiber cable with Ø 900 µm buffer (TPE-E)
- Outside the casing: Ø 3 mm fiber cable with Kevlar strain-relief with bend protection both at the fiber connector and the flange.
- Different connector types including optional end caps (see p. 52) and amagnetic connectors (see p. 53)

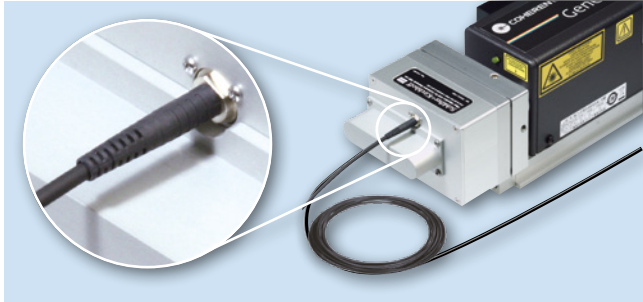


optional:
End
Caps

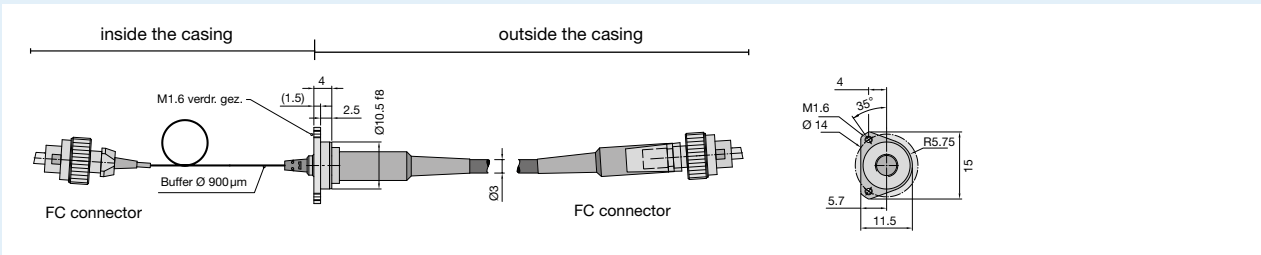
Detailed data sheets, up-to-date technical information, technical drawings including step files, accessories, extensive technotes section and FAQs:
www.sukhamburg.com



Examples:



Dimensions



Order Options for Casing Feed-throughs (For fiber specifications, please see p. 52ff.)

Order Code CFT - PMC - 780 - 28ET/20E -30/120

Flange type:

CFT = Casing feed-through

Fiber:

SMC = single-mode fiber cable

PMC = polarization-maintaining fiber cable

MMC = multimode fiber cable

Fiber Type (row 1) including:

Single-mode/PM: Nominal cut off wavelength, and

Si (Pure Silica core),

RGB (broad band fibers 400- 680 nm),

L (low NA fibers, large MFD) or

H (high NA fibers), when stated

Multimode: Core type:

S (Step index) or G (Gradient index), add "-"

Wavelength range: UV/VIS or VIS/NIR, add "-"

Core diameter, add "-"

Numerical aperture NA

Cable length in cm (in = vacuum side / out)

Note: Only one cable length means identical lengths for in and out!

28ET / 20E Fiber connectors (in / out) Connector Codes

1st connector Type (mandatory):

1 FC wide key (type 'N' 2.14 mm), **standard**

2 FC narrow key (type 'R' 2 mm)

3 F-SMA (PC, 0°-polish only), multimode only

6 E2000, no special features E, T

7 AVIM (comp. to LSA), no special features E, T

1st fiber end polish (mandatory):

0 PC (0°-polish)

8 APC (8°-polish), **standard**

1st special features (optional):

E with end cap (single-mode/PM only, no spec. feat. C)

T amagnetic (titanium), (no spec. feat. C)

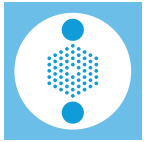
C core-centered (single-mode only, no spec. feat. E, T)

Insert "/" and repeat for 2nd fiber end,

Note: Only one Connector Code means identical connector choices for both fiber ends!

PCF Broadband Fiber Cables

Endlessly single-mode, photonic crystal fibers series with Gaussian intensity profile



PCF-Fiber

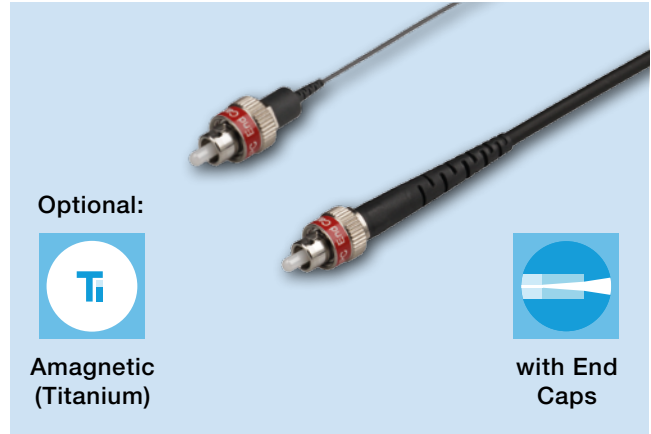
Endlessly single-mode, photonic crystal fiber cables series PCF-P with approx. Gaussian intensity profile and low-stress fiber connectors with end caps.

- Single-mode or single-mode polarization-maintaining
- Broadband fiber with wavelength range 350 nm - 1200 nm
- PCF fiber with 5 μm or 10 μm core, pure silica
- Measured values for fiber NA: NAe^2
- Large Mode-field diameter almost independent of wavelength
- Fiber patch cable with \varnothing 900 μm buffer or as \varnothing 3 mm cable with Kevlar strain-relief
- Connectors type FC with 0°-polish or 8°-polish



PCF-SM-Fiber

- PM only: Polarization axis is indicated by connector index key (slow axis)
- Amagnetic titanium connectors for connectors of type FC PC or FC APC
- End caps for a smaller power density at the fiber end-faces



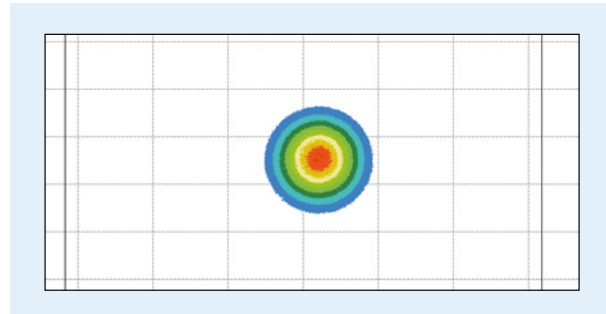
Detailed data sheets, up-to-date technical information, technical drawings including step files, accessories, extensive technotes section and FAQs: www.sukhamburg.com



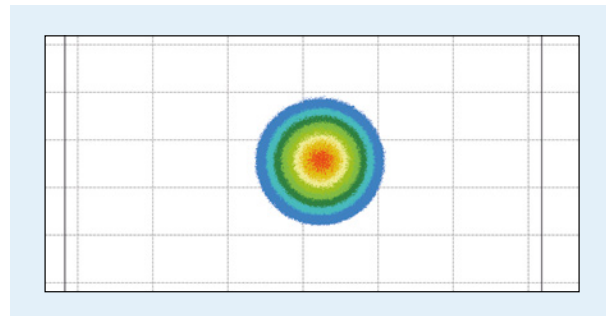
Note: PCF fiber cables are subject to ongoing R&D processes at Schäfter+Kirchhoff. Please contact us for details and availability.

Measured Beam Profiles

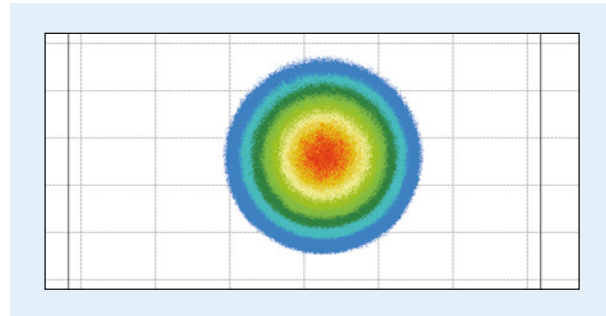
@ 405 nm



@ 520 nm



@ 940 nm



Bulkhead Fiber Adapters – Overview

Fiber Adapters without Optics

Bulkhead fiber adapters are used either for beam outputs, where no collimation or focusing of the radiation exiting the fiber is necessary, or for beam coupling into connectorized fibers, when a separate coupling optics such as a microscope optics is used.

- FC, F-SMA and LSA (comp. with DIN, AVIO or AVIM) connector
- Inclined coupling axis for APC (angled polish)
- Axial stop of the fiber ferrule for a constant focus position (FC and LSA only)
- Grub screw for an additional locking of the fiber ferrule (FC and LSA only)
- Different mechanical designs
- TILT alignment as an option
- Mechanics made of Titanium as an option



Detailed data sheets, up-to-date technical information, technical drawings including step files, accessories, extensive technotes section and FAQs:
www.sukhamburg.com



Order Options		Bulkhead Fiber Adapters (More information on www.sukhamburg.com)							
row	Connector Type / Polish angle	Ø 12 mm	Ø 25 mm	System Mount Ø 19.5 mm	Flange Mount w/o Flange	Flange Mount w. Flange Ø 20 mm	Flange Mount w. Flange Ø 25 mm	TILT	Titanium
1	FC-PC, 0°	12AF-0-FC	25AF-0-FC	on request	10AF-0-FC	10AF-0-FC+PP1020	10AF-0-FC+PP1025	-	-
2	FC-PC, 0°	12AF-0-FC-Ti	on request	on request	10AC-0-FC-Ti	10AF-0-FC+PP1020-TI	on request	-	Yes
3	FC-PC, 0°	-	25AM-0-FC	19.5AC-0-FC	-	-	-	Yes	-
4	FC-PC, 0°	-	on request	19.5AC-0-FC-TI	-	-	-	Yes	Yes
5	FC-APC, 8°	12AF-4-FC	25AF-4-FC	on request	10AF-4-FC	10AF-4-FC+PP1020	10AF-4-FC+PP1025	-	-
6	FC-APC, 8°	12AF-4-FC-Ti	on request	on request	10AF-4-FC-Ti	10AF-4-FC+PP1020-TI	-	-	Yes
7	FC-APC, 8°	-	25AM-4-FC	19.5AC-4-FC	-	-	-	Yes	-
8	FC-APC, 8°	-	on request	19.5AC-4-FC-TI	-	-	-	Yes	Yes
9	F-SMA, 0°	12AF-0-SMA	25AF-0-SMA	on request	10AF-0-SMA	20AF-0-SMA	10AF-0-SMA+PP1025	-	-
10	F-SMA, 0°	-	25AM-0-SMA	19.5AC-0-SMA	-	-	-	Yes	-
11	F-SMA, 5° ¹⁾	-	25AM-23-SMA	19.5AC-23-SMA	-	-	-	Yes	-
12	F-SMA, 8° ²⁾	-	25AM-4-SMA	19.5AC-4-SMA	-	-	-	Yes	-
13	LSA-PC, 0° ³⁾	12AF-0-LSA	25AF-0-LSA	on request	10AF-0-LSA	10AF-0-LSA+PP1020	10AF-0-LSA+PP1025	-	-
14	LSA-PC, 0° ³⁾	-	25AM-0-LSA	19.5AC-0-LSA	-	-	-	Yes	-
15	LSA-APC, 8° ⁴⁾	12AF-4-LSA	25AF-0-LSA	on request	10AF-4-LSA	10AF-4-LSA+PP1020	10AF-4-LSA+PP1025	-	-
16	LSA-APC, 8° ⁴⁾	-	25AM-4-LSA	19.5AC-4-LSA	-	-	-	Yes	-

¹⁾ Compatible to fiber connectors of type SMA-905 High Power with a 5° polish
²⁾ Compatible to fiber connectors of type SMA-905 High Power with a 8° polish
³⁾ Compatible with connectors of type DIN-PC, AVIO-PC and AVIM-PC
⁴⁾ Compatible with connectors of type DIN-APC, AVIO-APC and AVIM-APC

Order Examples

Adapter FC-APC, 8° to Ø 12 mm:

Order Code

12AF-4-FC

Adapter LSA-APC, 8° to System Mount Ø 19.5 mm:

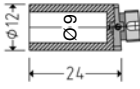
Order Code

19.5AC-4-LSA

Bulkhead Adapters: Fiber Adapters without Optics

Dimensions – Bulkhead Adapters

12AF compact design with $\varnothing 12$ mm outer diameter. Interior varnished in matt black.



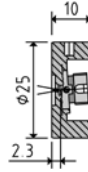
Order Code

FC-APC adapter
12AF-4-FC

Order Code

FC-PC adapter
12AF-0-FC

25AF FC adapter with $\varnothing 25$ mm fit for microbench system.



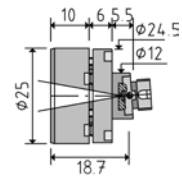
Order Code

FC-APC adapter
25AF-4-FC

Order Code

FC-PC adapter
25AF-0-FC

25AM FC adapter with $\varnothing 25$ mm fit for microbench system with integrated tilt adjustment for aligning the axis of the emitted radiation.



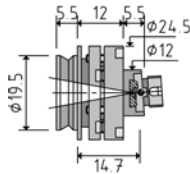
Order Code

FC-APC adapter
25AM-4-FC

Order Code

FC-PC adapter
25AM-0-FC

19.5AC FC adapter with tilt adjustment for aligning the axis of the emitted radiation. With system mount $\varnothing 19.5$ mm.



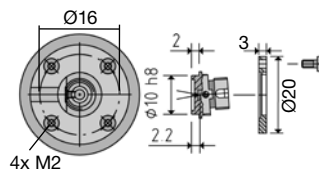
Order Code

FC-APC adapter
19.5AC-4-FC

Order Code

FC-PC adapter
19.5AC-0-FC

10AF FC adapter as OEM version with bearing flange.



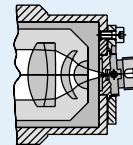
Order Code

FC-APC adapter
10AF-4-FC+PP1020

Order Code

FC-PC adapter
10AF-0-FC+PP1020

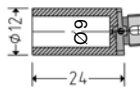
Application: FC-APC adapter with bearing flange for fiber coupling by means of a microscope lens



Bulkhead Adapters: Amagnetic Adapters made of Titanium

Dimensions – FC Fiber Adapters without Optics

12AF-...-Ti compact design with $\varnothing 12$ mm diameter. Interior varnished in matt black.



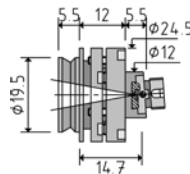
Order Code

FC-APC adapter
12AF-4-FC-Ti

Order Code

FC-PC adapter
12AF-0-FC-Ti

19.5AC-...-Ti FC adapter with tilt adjustment for aligning the axis of the emitted radiation. With standard adapter flange $\varnothing 19.5$ mm.



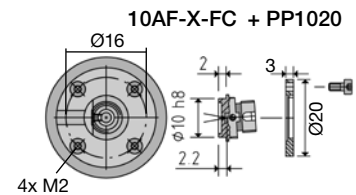
Order Code

FC-APC adapter
19.5AC-4-FC-Ti

Order Code

FC-PC adapter
19.5AC-0-FC-Ti

10AF-...-Ti FC adapter as OEM version with bearing flange.



Order Code

FC-APC adapter
10AF-4-FC+PP1020-Ti

Order Code

FC-PC adapter
10AF-0-FC+PP1020-Ti



Partial selection only.
More on <https://www.sukhamburg.com>

Accessory: Fiber Connector Cleaning Tool FCCT01

Cleaning tool for fibers with connectors of type FC-PC and FC-APC

The Fiber Connector Cleaning tool FCCT01 from Schäfter+ Kirchhoff is a cloth cleaning tool (more than 500 cleanings per unit) specially designed for cleaning fiber connectors of type FC-PC and FC-APC.

It is highly effective at removing contaminants from the fiber end-face, restoring the optical performance.



Accessories: FC Mating Sleeves

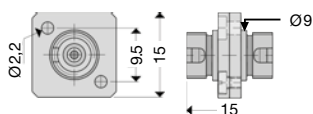
for direct fiber-to-fiber coupling of core-centered single-mode fibers.

Mating sleeves provide an uninterrupted physical contact between two single-mode fiber cables SMC with core-centering. Two connectors of type FC-PC (0°-polish) or of type FC-APC (8°-polish) can be connected.

For fiber-to-fiber coupling of Single-mode fibers without core centering or PM fibers, see fiber-fiber couplers 60FF page 22.

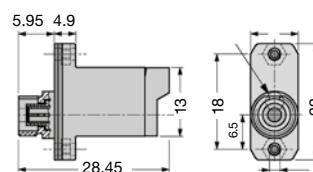
Dimensions – FC Mating Sleeves

Mating sleeves for two FC connectors
(panel mount, wide key):



Order Code 60C-FC/FC

Hybrid adapter for joining connector type E-2000 to
connector type FC (panel mount):



Order Code 60C-FC/E2000

Accessories: FC Protection Caps

Protection caps for FC Fiber connectors and FC Receptacles

Protection caps
for FC fiber connectors, stainless steel

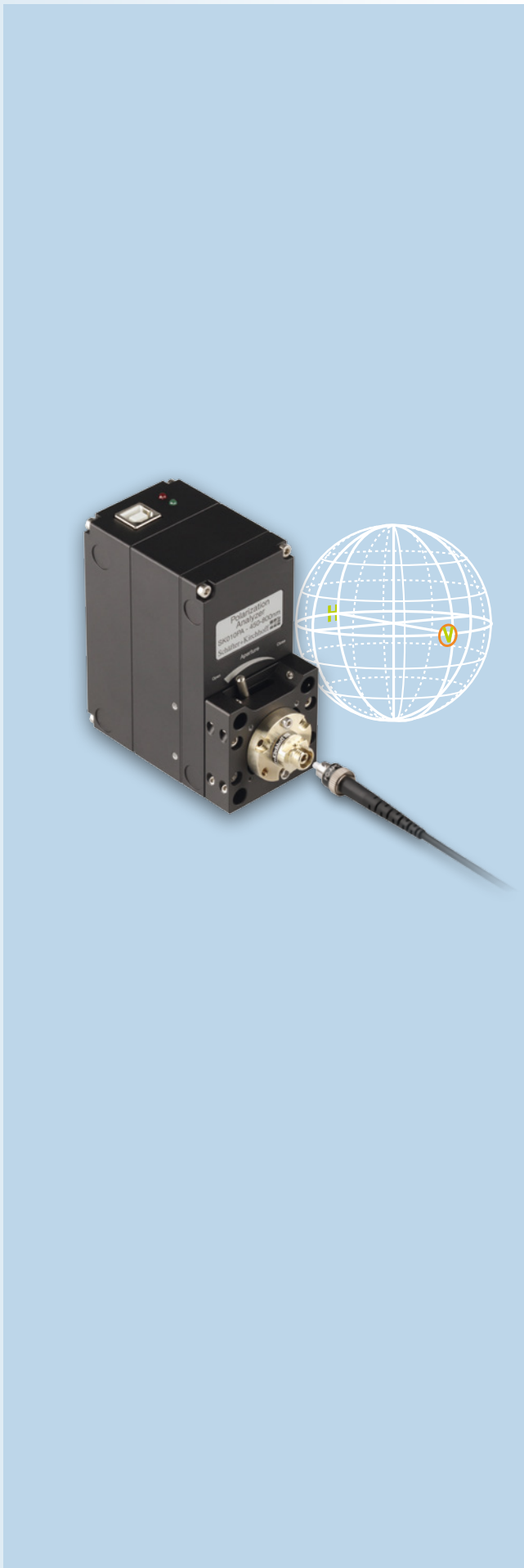
Protection cap **Order Code** 60FC-CAP-FC-S1

Protection caps, 10 pieces **Order Code** 60FC-CAP-FC-S



Measurement Tools

**Measurement Tools for
Polarization-Maintaining
Fibers: Polarization
Analyzer**



■ Measurement Tools

Polarization Analyzer ————— 66

Different Fields of Use ————— 68

Configurations and Accessories ————— 70

Polarization Analyzers Series SK010PA

Universal measurement and test system with multiple wavelength ranges for free-beam applications and polarization-maintaining fiber cables

The polarization analyzers SK010PA are universal measurement and test systems for coupling laser beam sources into polarization-maintaining fiber cables. They were developed from practical experience with a focus on high usability.

The polarization analyzer is a plug&play device and connects directly to the USB port of a Windows device. The device is compact and can be easily integrated within existing systems. Alignments and measurements are performed rapidly. A real-time measurement of the Stokes parameters is performed and shown in an interactive display that depicts the state of polarization on a Poincaré sphere.

Main features include:

- Determination of the state of polarization (SOP), with all four Stokes parameters, PER (Polarization extinction ratio), degree of polarization (DOP), ellipticity, etc.
- USB 2.0-powered device (control, data transfer and power supply)
- Display of the SOP on Poincaré sphere or as polarization ellipse
- Special routines for PM-fiber evaluation and polarization alignment
- Compatible with microbench system, rail or cage system for free beam applications, FC APC adapter included for fiber applications



Detailed data sheets, up-to-date technical information, technical drawings including step files, accessories, extensive technotes section and FAQs:
www.sukhamburg.com



Order Options for Polarization Analyzer Series SK010PA

Order Code	SK010PA - VIS	Wavelength range:
		UV+ 350 – 450 nm
		UV 370 – 450 nm
		UVIS 400 – 700 nm
		VIS 450 – 800 nm
		NIR 700 – 1100 nm
		IR 1100 – 1660 nm

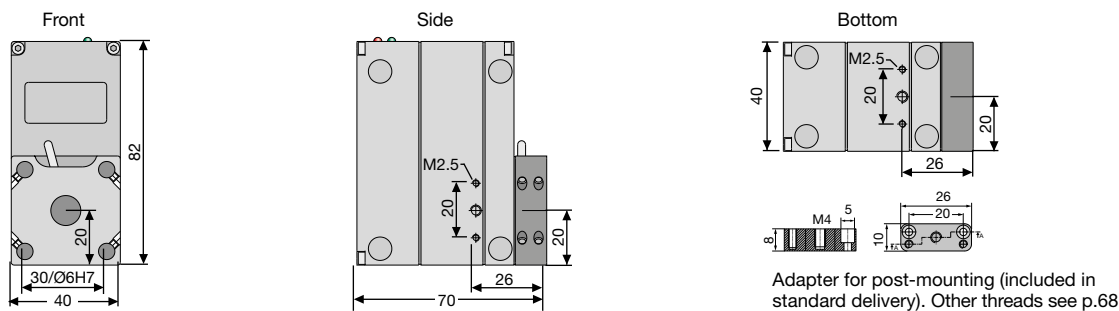
Standard delivery includes:

- USB cable
- Adapter for wide key fiber connectors of type FC-APC: PA-FC-4-0
- Adapter for post-mounting: PA-AP-M4
- Operating software: SKPolarizationAnalyzer for WINDOWS 7, WINDOWS 10 Vista/XP (32/64 Bit)
- DLLs included

Technical Specifications

Interface	USB 2.0	Sampling rate	15 Hz
Power Supply	via USB	SOP accuracy	$\pm 0.4^\circ$ on Poincaré sphere
Fiber adapter	FC-APC (standard), optional: FC-PC, DIN AVIO, E2000 and SC	PER accuracy	PER dependent, 0.5dB @ 25dB
Free beam diameter	max. 4 mm	DOP accuracy	5%
Power range:	0.01 – 50 mW	Warm-up time	5 min
		Housing:	40x70x82 mm (WxLxH)
		Temp. range:	10 - 36 °C

Dimensions



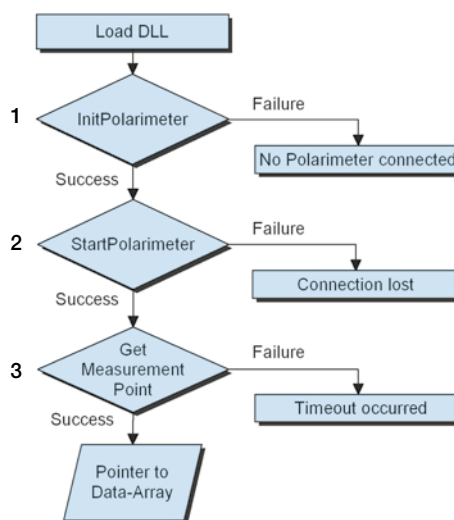
Analysis Software SKPolarizationAnalyzer

- Polarization extinction ratio (PER) measurement
- Adjustment support for PM-fiber-coupling of high and low coherent sources
- Measurement results can be logged and saved
- Log file of measurements over a designated time
- Calibration of polarization zero phase and resetting to the original factory settings
- Integration of the polarimeter in customizable software with DLL

External programming

There is no restriction in the inclusion of any of the SKPolarizationAnalyzer software features in a software project produced by or for a customer. This applies to all dialog boxes for the input of different parameters, all graphical displays and the measurement of the extinction ratio of the polarization-maintaining single-mode fibers.

For integrating it into a customized software application, only three functions are needed to obtain a single measurement point: Initialize, start the polarization analyzer, and make a measurement.



Measurement Method:

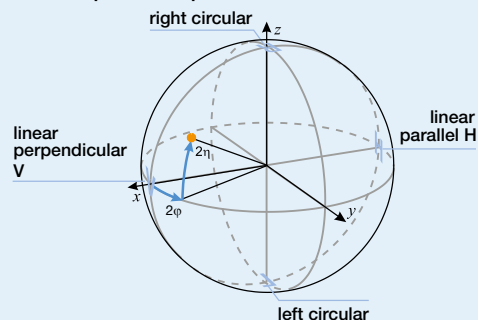
The radiation coupled to the polarization analyzer is passed through a rotating quarter-wave plate and fixed polarizer before being recorded by a photodetector.

The software SKPolarizationAnalyzer evaluates the Stokes parameters retrieved from a detailed analysis of the photodiode signal and the time/position information of the quarter-wave plate.

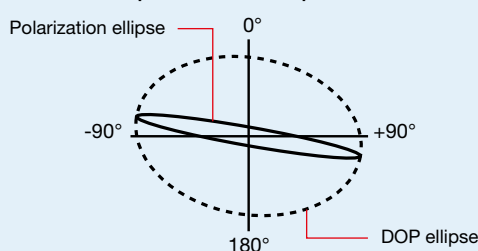
The state of polarization is then depicted on the Poincaré sphere, where any change in the state of polarization including the direction of rotation (depicted on the northern or southern hemisphere) is easily visible.

A polarization ellipse, a common representation of the state of polarization, is also shown. For sources with low coherence, a DOP ellipse complements the polarization visualization.

Poincaré Sphere- Representation of Polarization States



Polarization Ellipse and DOP ellipse



Different fields of use for the Polarization Analyzer

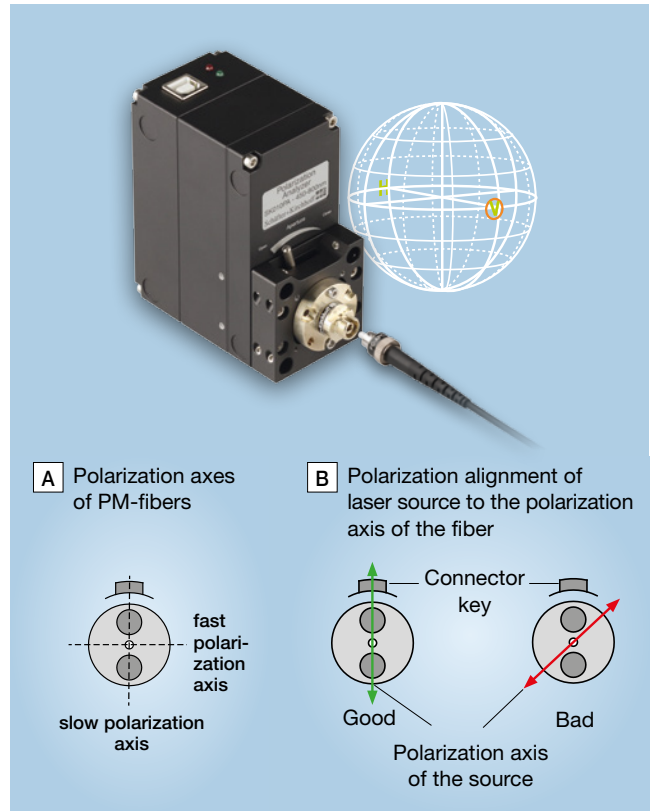
Polarization Alignment for Coupling into Polarization-Maintaining Fibers

The SK010PA Polarization Analyzer provides procedures for the alignment of the incoming polarization direction of the source with the polarization axes of the fibers and for the measurement of the resulting Polarization Extinction Ratio (PER).

Polarization-maintaining single-mode fibers guide coupled radiation in two perpendicular principle states, the fiber polarization axes (also called the slow and fast axis, see [A]). The polarization extinction ratio PER of fiber-coupled radiation is the ratio between the optical power levels coupled to the two polarization axes of the fiber. The polarization analyzer is used to optimize the polarization alignment of the polarization axis of the light source to the polarization axis of the fiber [B] by rotating the input polarization axis of the source.

For the two polarization axes the speeds of propagation are different. When a linearly polarized radiation is not coupled exactly into one of these states, the radiation is split up in two perpendicular components coupled to the polarization axes of the fiber, respectively. At the fiber exit the difference of propagation speed causes a phase shift which also depends on the length of the fiber. If this phase shift is smaller than the coherence length of the laser source, the radiation recombines to an elliptical polarization state.

If the coherence length of the laser source is smaller than the phase shift the emerging radiation is partly depolarized. The polarization analyzer supports adjustment for both cases.

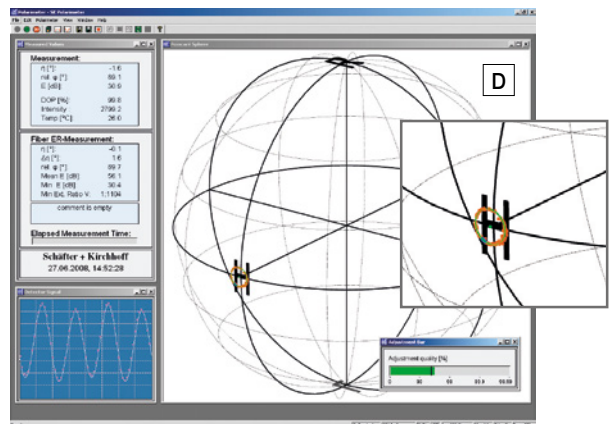
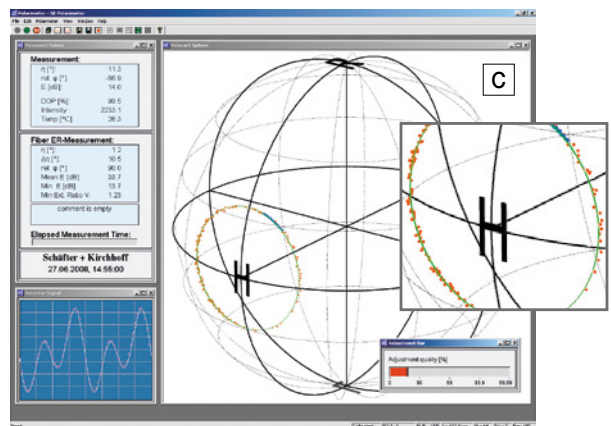


1 Adjustment using the Poincaré sphere

If the phase shift causes the radiation to recombine to an elliptical state, the evaluation using the Poincaré sphere is used. The difference in speed and the resulting phase shift of the two fiber axes depend on temperature and stress. As a consequence, the polarization at the fiber axis is not stable when there is an alignment mismatch. The polarization changes when the fiber is touched and fluctuates with temperature. But the exit polarization is still not random. When they are mapped on the Poincaré sphere, it becomes apparent that all possible exit states lie on a common circle. The radius of this circle indicates the quality of the alignment, since it shows the angle deviation between the fiber polarization axis and the polarization axis of the incoming radiation. For an optimally aligned ideal fiber, the data circle converges to a single point, the center of the circle. Generally, this center represents the mean polarization state of the particular alignment. For an ideal PM-fiber, it is located on the equator of the Poincaré sphere.

The correspondence between circle radius and polarization alignment is used during the Polarization Analyzer's fiber alignment procedure. The procedure starts with the recording of exit polarization states while the temperature is changed, or the fiber is carefully bended, to cause the exit polarization to fluctuate. A circle is then automatically fitted to the data points, and the mean and minimal PER are displayed [C]. In the example shown, the circle on the Poincaré sphere has a large radius. During continuous measurement of the exit polarization state, the fiber axis is then rotated with respect to the polarization axis of the laser source. The optimum alignment is reached when the exit polarization state approaches the circle center on the Poincaré sphere as far as possible. A color-coded logarithmic bar plot helps to find the minimum distance.

A second measurement [D] then reveals the parameters of the optimized polarization alignment of the fiber.



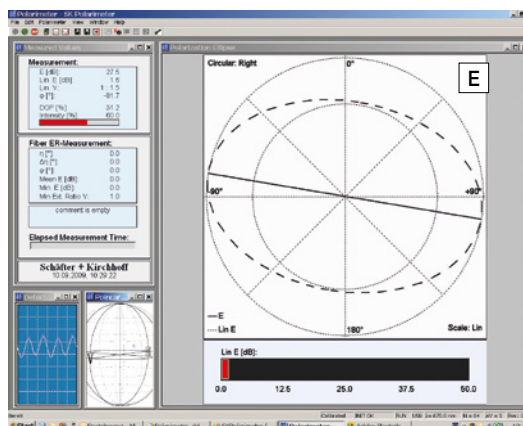
2 Adjustment with DOP Ellipse

As mentioned above, recombination to an elliptical polarization state is only possible, if the coherence length of the laser source is larger than the phase shift caused by the difference in propagation speed. If the coherence length of the laser source is smaller than the phase shift caused by the difference in propagation speed then the light is partly depolarized and this is not possible.

The described circle on the Poincaré sphere cannot be observed- all exit polarization states lie on a single spot. Instead, the misalignment solely results in a reduced degree of polarization (DOP).

In this case the DOP-ellipse representation is used for fiber alignment [E], where a polarization measurement with a rotating linear polarizer is simulated. The DOP-ellipse (dotted line) becomes a circle for fully depolarized light.

The narrower the DOP-ellipse becomes, the better the incoming polarization axis is aligned to one of the polarization axes of the fiber. For an ideal alignment the ellipse would degrade to a line.



Typical Configuration: Free Beam Measurements

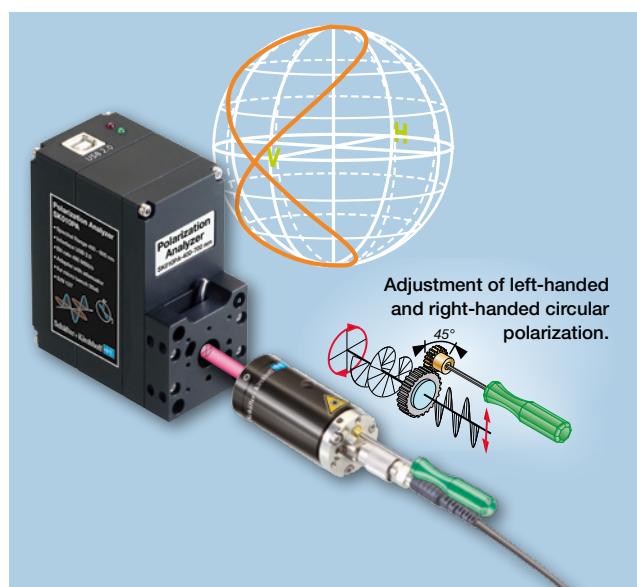
The polarization analyzer can also be used for setting a well-defined state of polarization for free-beam applications. For these type of measurements, a correct alignment of the laser beam axis with the polarization analyzer is essential. This can be done using the micro-bench, or 30 mm cage system and using the connection with 4 rods (for details see page 70) or the rail system.



Application: Adjustment and Evaluation of Quarter-Wave Plates

The SK0101Polarization Analyzer can be used to align and quantify retardation optics, e.g. fiber collimators with integrated quarter-wave plates produced by Schäfter+Kirchhoff (for details see page 37).

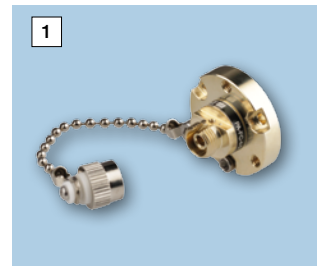
For these collimators, the outcome polarization is adjusted by rotating the quarter-wave plate with a special tool. A full rotation corresponds to a figure-of-eight on the Poincaré sphere. Circularly polarized light is set when the poles are reached, with right-handed circular polarization located at the north pole, and left-handed polarization located at the south pole. If the actual retardation of the optics deviates from the desired value then the extreme values do not reach the poles. The polarization analyzer thus provides a measure of the actual retardation of the optics.



Adapters with and without Optics

Adapters for fiber cables with and without optics with different receptacles for attachment to the series SK010PA Polarization Analyzers.

- Without optics: Receptacles type FC (0° and 8°-polish, wide and narrow key), F-SMA (0°-polish), SC (0° and 8°-polish), E2000 (0° and 8°-polish), and LSA (0° and 8°-polish, compatible with connectors of type DIN, AVIO and AVIM)
- With optics:
 - Receptacles type FC (0° and 8°-polish, wide key)
 - Focal lengths 6.2 mm or 11 mm
 - Various AR coatings UV-IR



Order Options Polarization Analyzer Adapters (More information on www.sukhamburg.com)

row	Connector Type, Polish angle	without optics	with optics		Titanium
		Order Code	Focal length 6.2 mm	Focal length 11 mm	
1			PA-FC-0-A6.2S-01 (370 nm - 600 nm)	PA-FC-0-A11-01 (370 nm - 600 nm)	
2	FC-PC, 0° wide key	PA-FC-0-0	PA-FC-0-A6.2S-02 (600 nm - 1050 nm)	PA-FC-0-A11-02 (600 nm - 1050 nm)	-
3			PA-FC-0-A6.2S-03 (1050 nm - 1550 nm)	PA-FC-0-A11-02 (1050 nm - 1550 nm)	-
4	FC-PC, 0° narrow key	PA-FC-0-0-R	-	-	-
5			PA-FC-4-A6.2S-01 (370 nm - 600 nm)	PA-FC-4-A11-01 (370 nm - 600 nm)	-
6	FC-APC, 8° wide key	PA-FC-4-0	PA-FC-4-A6.2S-02 (600 nm - 1050 nm)	PA-FC-4-A11-02 (600 nm - 1050 nm)	-
7			PA-FC-4-A6.2S-03 (1050 nm - 1550 nm)	PA-FC-4-A11-03 (1050 nm - 1550 nm)	-
8			PA-FC-4-0-N-Ti	-	-
9	FC-APC, 8° narrow key	PA-FC-4-0-R	-	-	-
10	F-SMA, 0°	PA-SMA-0-0	-	-	-
11	SC, 0°	PA-SC-0-0	-	-	-
12	SC, 8°	PA-SC-4-0	-	-	-
13	E2000, 8°	PA-E2000-4-0	-	-	-
14	E2000, 0°	PA-E2000-0-0	-	-	-
15	LSA-PC, 0°	PA-LSA-0-0	-	-	-
16	LSA-APC, 8°	PA-LSA-4-0	-	-	-

Adapters for Mounted Optics

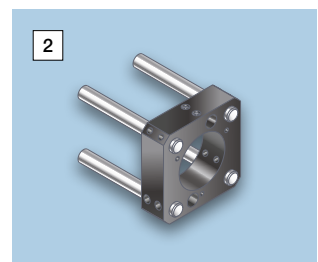
Adapter for Ø12, Ø25 and Ø32 mm optics incl. 4 Rods

Order Options for Micro Bench Adapters

Order Code PA-48MC-12 for Ø12 mm

Order Code PA-48MC-25 for Ø25 mm

Order Code PA-48MC-32 for Ø32 mm



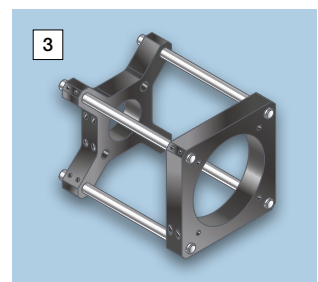
Adapters for Mounted Optics

Adapters for Ø45 and Ø55 mm fiber collimators (Type 60FC-T or 60FC-L, page 27ff) incl. 8 Rods

Order Options for Micro Bench Adapters

Order Code PA-48MC-45 for Ø45 mm

Order Code PA-48MC-55 for Ø55 mm

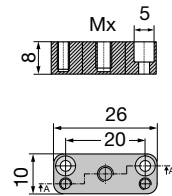


Adapters for Post-Mounting

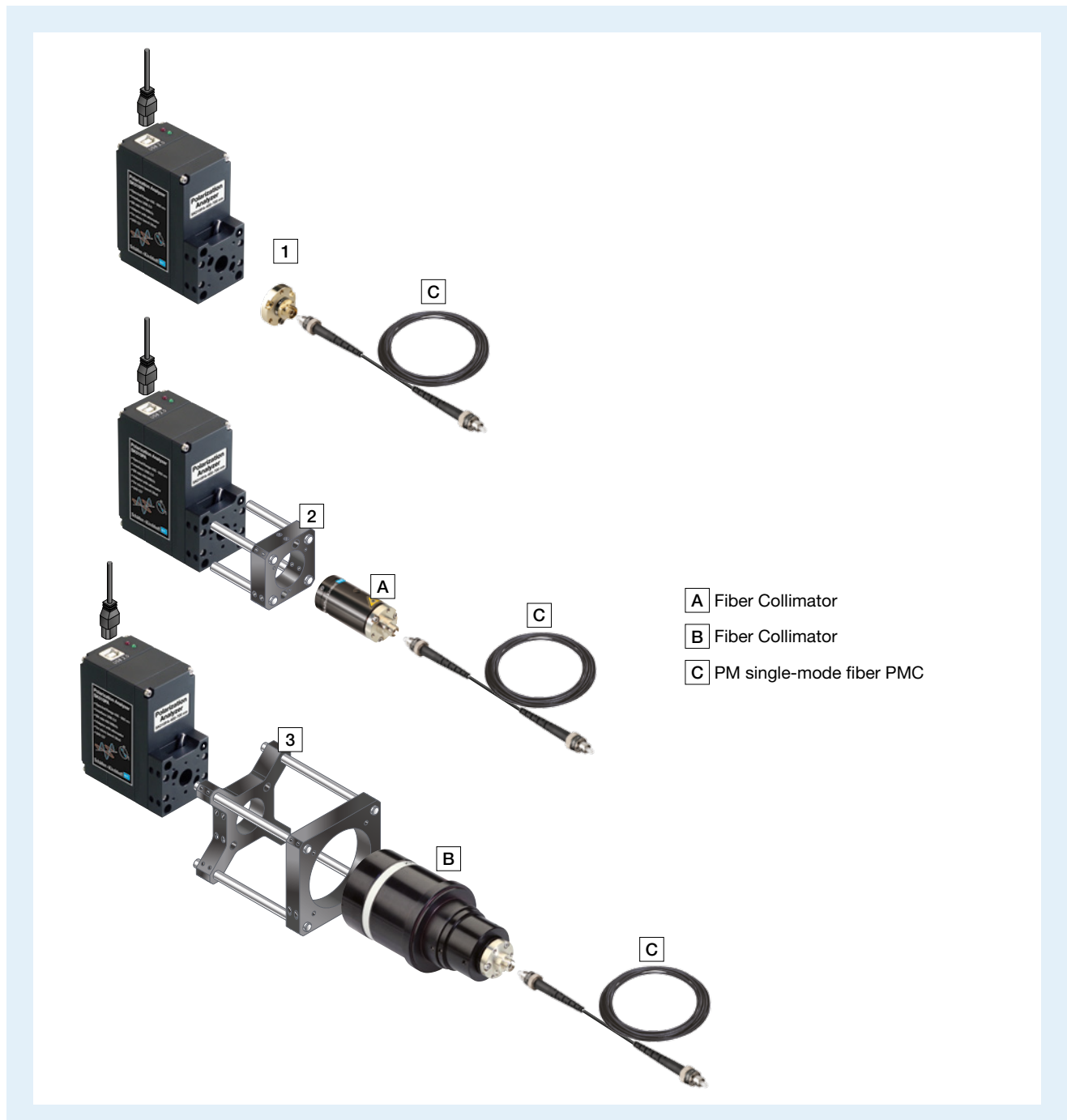
Order Options for Adapter

Order Code PA - AP - M4
 Thread M4
 M5
 M6

Dimensions



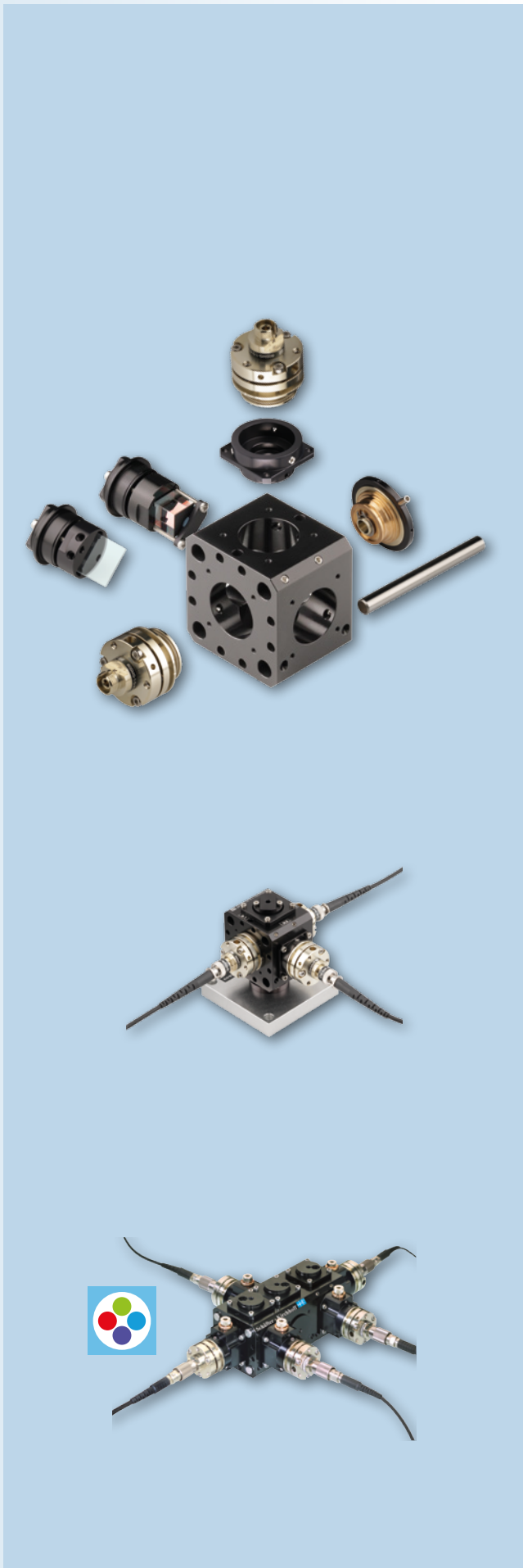
Typical Configurations



- A** Fiber Collimator
- B** Fiber Collimator
- C** PM single-mode fiber PMC

Multicube

**multicube™ –
Components and Systems
for the rugged and compact
implementation of a wide
range of different setups.**



■ multicube™ – Components and Systems

Construction Kit multicube™	74
Combination Cubes and Plates	75
Optics for the multicube™ System	76
Accessories: Flanges, Adapters, Rods, Screws and Tools	79
Multicube™ Systems	81
Fiber-coupled Faraday Isolator	81
Laser Attenuators 48AT	82
Electro-Magnetic Shutter	83
Beam Splitters	84
Beam Combiners	85
RGB and RGBV Laser Beam Combiners	86

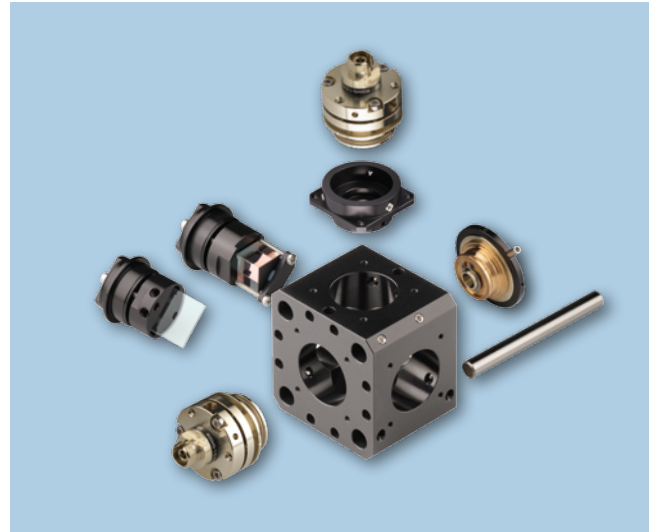
Construction Kit multicube™ Series 48MC

compatible with established cage and microbench systems

The major design features of the Schäfter+Kirchhoff multicube™ components ensure highly rugged and warp-resistant setups, especially for single-mode fiber coupling. The multicubes™ are combined and fixed using four Ø 6 mm rods in parallel and are compatible with established microbench systems.

The multicube™ construction system is the perfect integration platform for laser beam couplers, beam combiners, beam splitters, polarizers or retardation optics. Self-supporting modules and laser beam assemblies can be created that are extremely resistant to torsion and contain complementary components.

The multicube™ system is compatible with the established cage system and the microbench system



Implementation of an essentially limitless range of setups: Examples

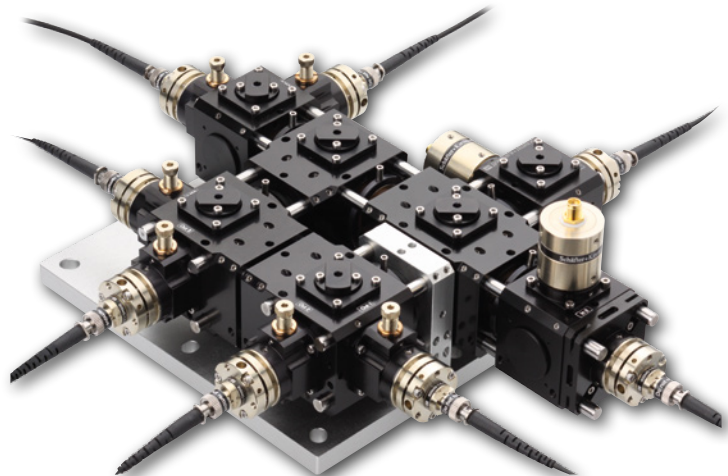
Fiber Port Cluster: 2 → 6

This unit splits the radiation from two polarization-maintaining (PM) fibers into 6 output polarization-maintaining fiber cables with high efficiency and variable splitting ratio.

The beam delivery system uses the compact, modular opto-mechanic units of the multicube™ system.

The modularity ensures that almost any desired system can be assembled that is compact and sealed.

For more details see page 90.

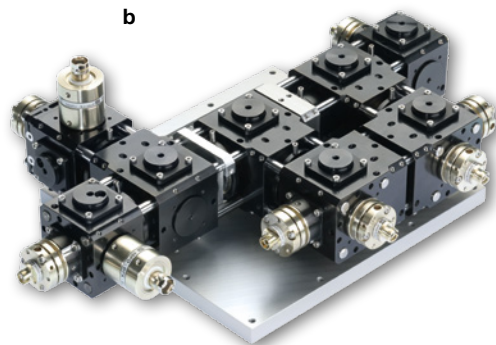
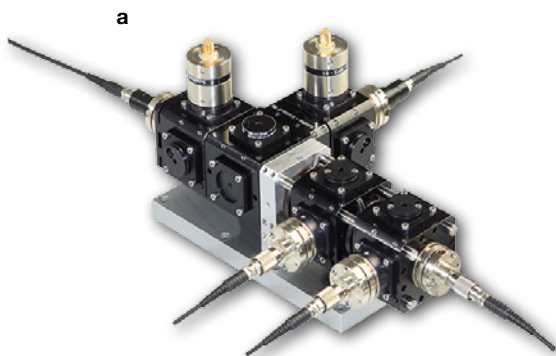


Dichroic Fiber Port Clusters:

It is also possible to combine beams of different wavelengths at the input port of a Fiber Port Cluster for the subsequent splitting of both components equally.

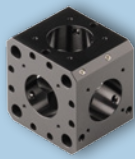
- Small wavelength difference, Type 48FC-x-x_dc-xxx: polarization beam splitter in combination with a dichroic wave plate (a),
- Large wavelength difference, Type 48FC-x-x_lp-xxx: superposition using a dichroic mirror (b)

For more details see page 92

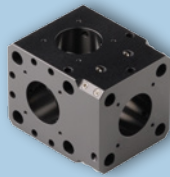


Combination Cubes and Plates 48MC

compatible with established cage and microbench systems



Single-Cube
with through-holes for
linear arrangements,
short design



Single-T-Cube
for T-arrangements



Mounting Plate
for mounting
Ø 19.5, 25 or 32 mm
system components

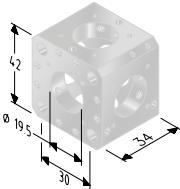


**Extended Mounting
Plate** for mounting
Ø 19.5 or 25 mm
system components

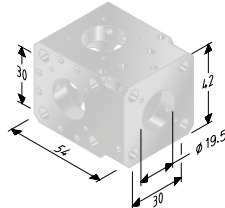


Mechanical Shutter
aperture Ø 3 mm
system mount
Ø 19.5 mm

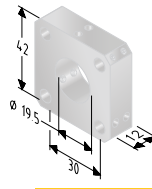
Dimensions



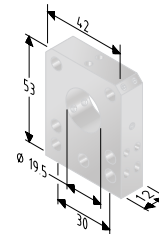
Order Code
48MC-SM-19.5



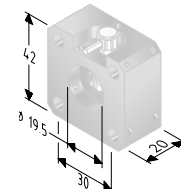
Order Code
48MC-LTS-19.5



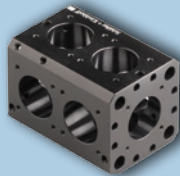
Order Code
48MC-MP-19.5
48MC-MP-25
48MC-MP-32



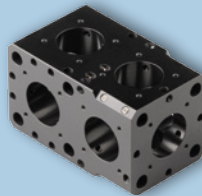
Order Code
48MC-SP-19.5
48MC-SP-25



Order Code
48AT-S



Double-Cube
with through-holes for
linear arrangements



Double-T-Cube
for T-arrangements

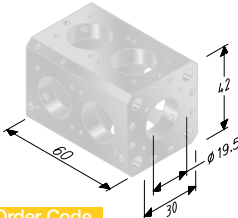


Mechanical Attenuator
with fine thread, aperture Ø 3 mm,
system mount Ø 19.5 mm

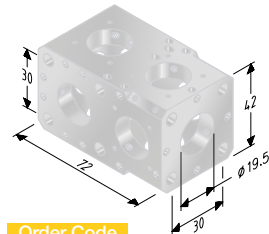


x/y Adjustment plate
for lateral adjustment,
translation 1 mm

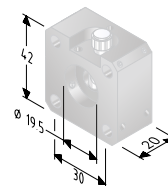
Dimensions



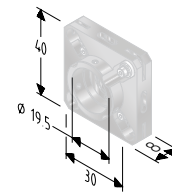
Order Code
48MC-LI-19.5



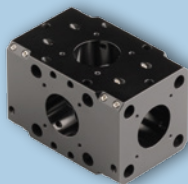
Order Code
48MC-LT-19.5



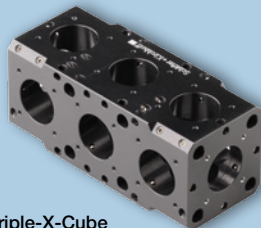
Order Code
48AT-A



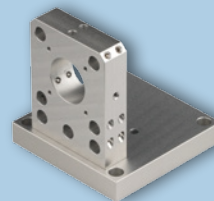
Order Code
48MB-19.5-SXY-1



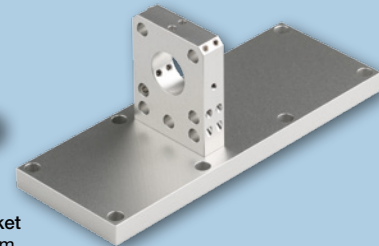
Single-X-Cube
for X-arrangements



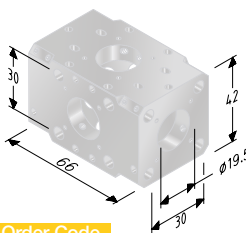
Triple-X-Cube
for X-arrangements



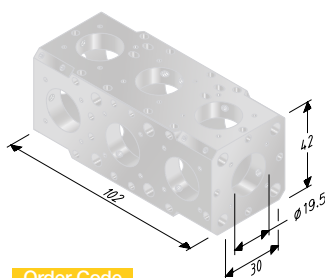
Extended Mounting Bracket
150 x 60 mm or 60 x 60 mm,
system mount Ø 19.5 mm



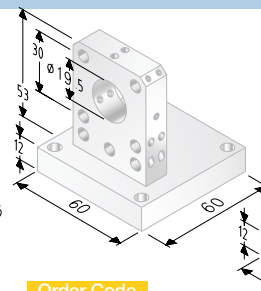
Dimensions



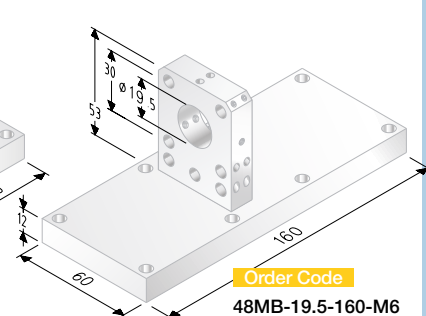
Order Code
48MC-LTD-19.5



Order Code
48MC-CL-19.5



Order Code
48MB-19.5-160-M6



Order Code
48MB-19.5-160-M6

Optics for the multicube™ System

Beam Splitter and Beam Combiner, Polarizer, Retardation Optics

Polarization Beam Splitters 48PM-CC

Beam-splitting cube with internal dielectric and polarizing multilayer coating. Adjustable mount, for mounting with clamp collar (included).

50:50 split ratio for linearly polarized input radiation with polarization direction $\alpha = 45^\circ$. Maximum transmission at $\alpha = 0^\circ$ (p-pol.) with maximum reflection at $\alpha = 90^\circ$ (s-pol.).

- Extinction ratio 10 000 : 1
- Clear aperture 6 mm
- Reflection angle 90°
- Broadband AR coating $R < 0.5\%$ per surface

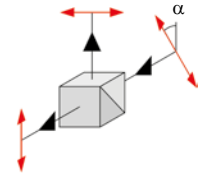


Order Options for Polarization Beam Splitters

Order Code 48PM-CC-A

Spectral range [nm]
 A = 450 - 700 nm
 B = 750 - 1100 nm
 C = 1100 - 1700 nm
 W = 450 - 1000 nm

Application:
 Beam splitter with adjustable splitting ratio, in combination with retardation optics 48WP-CA



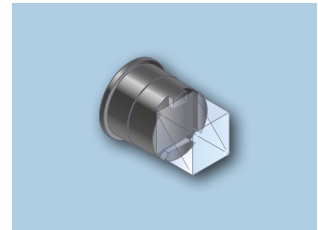
Beam Splitter Cubes 50/50 48BM-CC

With adjustable mount, for mounting with clamp collar (included).

Order Options for Beam Splitter Cubes 50/50 48BM-CC

Order Code 48BM-CC-A

Spectral range [nm]
 A = 450 - 700 nm
 B = 750 - 1100 nm
 C = 1100 - 1700 nm



Beam Splitters 98/2 48BS-CC-A

With adjustable mount, for mounting with clamp collar (included).

- 1 mm fused silica plate, uncoated
- 0.3° wedge angle for interference suppression
- Transmission 98 % (p-polarization)
- Reflection 1 % per surface (p-polarization)
- Clear aperture 10 mm



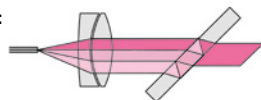
Order Options for Beam Splitters 98/2 48BS-CC-A

Order Code 48BS-CC-A

Spectral range [nm]
 A = 450 - 700 nm

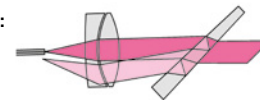
Beam splitter and beam combiner with wedge-shaped substrate:

Substrate without wedge:



Beams are reflected twice at the media/air interfaces. The reflected beam is finally parallel with the unreflected beam. Both beams interfere, which causes intensity instabilities (Etalon effect). If they are coupled into a fiber, they are both focused onto the same spot and are both coupled. The intensity is not stable due to the interference of the beams.

Substrate with wedge:



The original beam and the twice reflected beam are not parallel but inclined after passing the substrate with wedge. After focusing that results in two distinct laser spots. Only the unreflected beam overlaps with the mode field of the fiber and the reflected radiation is lost. The removal of interference prevents intensity instabilities.

Beam Combiners 48BC-CC-LP

Two laser beams of different wavelengths are coaxially combined into a single laser beam with equal polarization. In adjustable mount, for mounting with clamp collar (included).

- 1 mm fused silica plate with wavelength dependent dielectric coating and some with 0.3° wedge angle for interference suppression
- Long pass (LP) and short pass (SP) version
- Optimized for angle of incidence 45°, p-polarization
- Fused silica plate
- AR Coated reverse surface
- Clear aperture 10 mm
- Reflection up to 99%, transmission up to 95%

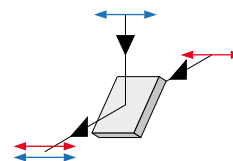
For a complete, fiber-coupled RGBV-Beam Combiner, see page 92.



	Reflection long pass	Transmission	Pol.
LP436	370 - 412	460 - 700	s
LP510	405 - 488	532 - 660	s
LP570	532 - 544	594 - 660	s
LP580	500 - 560	600 - 700	p
LP725	500 - 560	780 - 2100	p
LP800	630 - 780	820 - 880	s
	Reflection short pass		
SP1500	1650 - 1700	1200 - 1380	p

Application:

For the coincident coupling of laser diode beam sources of different wavelengths and identical polarization into one single-mode fiber



Order Options for Beam Combiner 48BC-CC-LP

Order Code 48BC-CC-LP xxx
 Edge wavelength [nm]

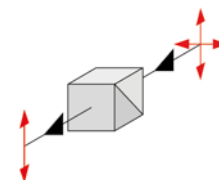
Polarizers 48PM-S

- Adjustable within adapter flange
- Polarization: linear
- Extinction ratio 10 000 : 1
- Clear aperture 3.5 mm
- Broadband AR coating: R < 0.5% per surface
- Variety of designs



Application:

For increasing the extinction ratio after collimating the radiation of a polarization-maintaining fiber



Order Options for Polarizer 48PM

Order Code 48PM-S-A
 Option S (standard) [A] Spectral range
 S-D (decentered) [B] A = 450 - 700 nm
 SXY1 (xy adjustment) B = 750 - 1100 nm
 AT-19.5AC (with attenuator) [C] C = 1100 - 1700 nm
 W = 450 - 1000 nm

Polarizer in adapter flange as 48MB-19.5AC

Order Code
 48MB-19.5AC

Polarizer as 48PM-S decentered 0.3mm for combining with beam splitter plate 48BS

Order Code
 48PM-S-D

Polarizer with attenuator in adapter flange 48AT-19.5AC-S1

Order Code
 48PM-AT-19.5AC

Retardation Optics $\lambda/2$ 48WP-2-CA

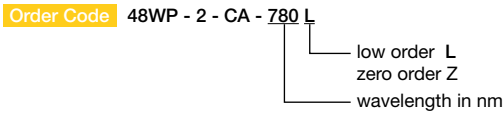
The half-wave plate rotates the polarization direction of a linearly polarized input beam.

- Clear aperture 5 mm
- In adjustable mount with self-locking tubular axis (0 - 360°)
- Rotation around axis that is inclined 2° with respect to the optical axis. This avoids interference and back-reflection
- Quartz plate
 - type L: low order for low angle sensitivity
 - type Z: zero order for low wavelength dependency

Further information:
www.sukhamburg.com

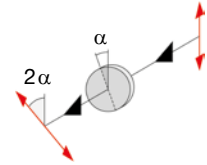


Order Options for Retardation Optics $\lambda/2$



Application:

In combination with polarization beam splitter 48PM-CC, beam splitter with adjustable splitting ratio

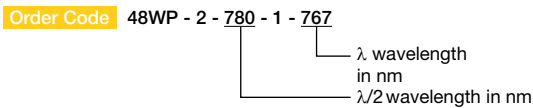


Dichroic Retardation Optics 48WP-2- λ -1- λ

The dichroic retardation plate is a $\lambda/2$ -plate for one wavelength and does not affect the polarization of another wavelength. The correctly positioned plate rotates two orthogonally polarized input beams of different wavelengths into linear polarization states in parallel.

- Clear aperture 5 mm
- In adjustable mount with self-locking tubular axis (0-360°)
- To avoid interference and back-reflection, the mount is inclined at 2° with respect to the tubular axis
- Quartz plate of low order

Order Options for Dichroic Retardation Optics



Application:

In combination with polarization beam splitter 48PM-CC, beam combiner for two wavelengths too close for dichroic beam combiners ($\Delta\lambda < 30$ nm)

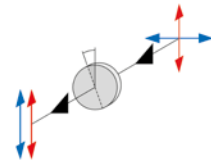


Photo Detectors / Si-Detector 48PD-BPX61

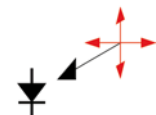
- Photodiode BPX 61
- Spectral range 400–1100 nm
- > 50 nA/lx, > 320 mV/lx, 72 pF, 20 ns
- Active area 7 mm²
- 3°-angled mount in housing for system mount Ø 19.5 mm
- Diode and SMA connector galvanically isolated

Order Options for Photo Detectors




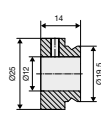

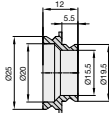

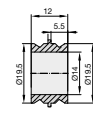

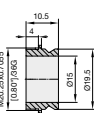

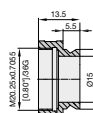

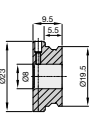
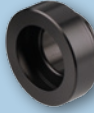
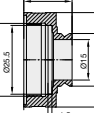

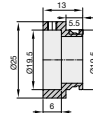

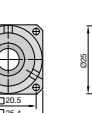
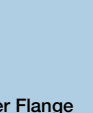
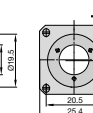

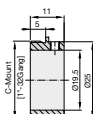

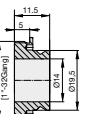
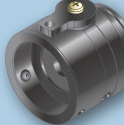
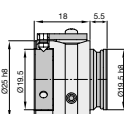
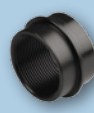
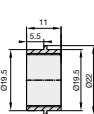

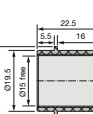

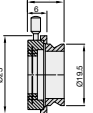

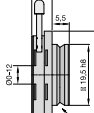

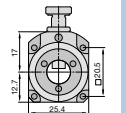

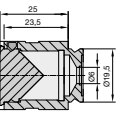

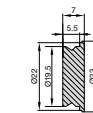
Application:

Power monitoring in combination with beam splitter 98/2 48BS-CC-PA



Accessories: Flanges and Adapters for System Mount Ø 19.5 mm

Schäfter+Kirchhoff offers numerous adapters and flanges suitable for incorporation into the multicube™ system. All standard adapters and flanges have Ø19.5 mm system mount with a 19.5 mm tightly fitting cylinder. Some can be mounted using flange mounting.

 <p>Adapter for adapting Ø 12 mm components for Ø 19.5 mm mounting</p>  <p>Order Code 12AM19.5</p>	 <p>Adapter for adapting Ø 25 mm components for Ø 19.5 mm mounting</p>  <p>Order Code 19.5AC-25</p>	 <p>Adapter Both ends with Ø 19.5 mm mount and v-groove</p>  <p>Order Code 19.5AC19.5</p>	 <p>Adapter for Microscope Lenses Adapter for Ø 19.5 mm to W0.8"x1/36" male</p>  <p>Order Code W0.8-19.5</p>	 <p>Adapter for Microscope Lenses Ø 19.5 mm to W0.8"x1/36" female</p>  <p>Order Code W0.8-I-19.5</p>
 <p>Adapter for attaching Optics with Ø 8 mm to Ø 19.5 mm for attaching e.g. 5M or 5PF</p>  <p>Order Code 8AM-19.5</p>	 <p>Adapter for Ø 25 mm or Ø 25.4 mm mounted optics</p>  <p>Order Code 19.5AF25.4-S</p>	 <p>Adapter Both ends with Ø 19.5 mm, male/female</p>  <p>Order Code AC19.5/19.5-S</p>	 <p>Adapter Flange for components with Ø 8 mm for fitting to Ø 19.5 mm system mount</p>  <p>Order Code 48MB-19.5 A</p>	 <p>Adapter Flange for components with Ø 8 mm to Ø 19.5 mm, decentered 0.3 mm</p>  <p>Order Code 48MB-19.5AC-D</p>
 <p>Adapter C-mount Adapter for Ø 25 mm to C-mount</p>  <p>Order Code C-mount-25</p>	 <p>Adapter C-mount Adapter for Ø 19.5 mm to C-mount</p>  <p>Order Code C-mount-19.5AC</p>	 <p>Shutter Clear Aperture 5 mm, both ends with Ø 19.5 mm male/female,</p>  <p>Order Code 13S-5-1</p>	 <p>Spacer with Ø 19.5 mm both ends</p>  <p>Order Code 48S-19.5</p>	 <p>Tube with Ø 19.5 mm both ends</p>  <p>Order Code 48T-19.5</p>
 <p>Iris Aperture Ø 1-13 mm</p>  <p>Order Code 13BL1-13</p>	 <p>Iris Aperture Ø 0-12 mm</p>  <p>Order Code 13BL0-12</p>	 <p>Adapter Flange with Attenuator Clear aperture: Ø 3 mm; Ø 19.5 mm system mount</p>  <p>Order Code 48AT-19.5-S1</p>	 <p>Light Trap for absorbing unused beams</p>  <p>Order Code 48LT-19.5</p>	 <p>Cap For Ø 19.5 mm system mounting</p>  <p>Order Code 48C-19.5</p>

Representative selection. For more please contact Schäfter+Kirchhoff.

Accessories and Tools for Assembly and Adjustment

Accessories



Rod for combining multicubes™

Order Code
48MC-6-L

L = 30
L = 75
L = 150
xxx = length of choice



Hex grub screw
DIN 914 M3x3-conical for mounting Ø 19.5 mm components with v-groove - set of 20/50 pcs.

Order Code
48-M3-3-914-20
48-M3-3-914-50

Hex Screwdriver
Order Code
50HD-15



Hex grub screw
DIN 913 M3x3-flat for fixing rods to multicubes™ - set of 20/50 pcs.

Order Code
48-M3-3-913-20
48-M3-3-913-50

Hex Screwdriver
Order Code
50HD-15



Hex screw DIN 912
M2 x 8 for mounting Ø 19.5 mm components using a clamp collar - set of 20/50 pcs.

Order Code
48-M2-8-912-20
48-M2-8-912-50

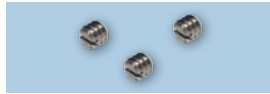
Hex Screwdriver
Order Code
50HD-15



Grub screw DIN 553
M1.6 x 1.5-conical for mounting Ø 8 mm components with v-groove - set of 20/50 pcs.

Order Code
48-M1.6-1.5-553-20
48-M1.6-1.5-553-50

Screwdriver
Order Code
9D-12

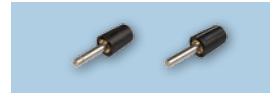


Grub screw DIN 551
M1.6 x 1.5 for fixing fiber ferrules to 60FC-... and 60SMF - set of 20/50 pcs.

Order Code
48-M1.6-1.5-551-20
48-M1.6-1.5-551-50

Screwdriver
Order Code
9D-12

Tools for Assembly and Adjustment



Eccentric tool
for laser beam couplers 60SMF and fiber collimators 60FC

Order Code
60EX-4
60EX-5
for focal length $f' \geq 20$ mm



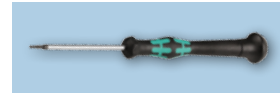
Eccentric tool
for fiber collimators 60FC-T and 60FC-Q...

Order Code
55EX-5



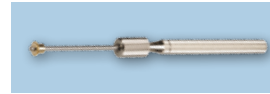
Screwdriver
WS 1.2 mm for grub screw in fiber ferrules and accessories 5M

Order Code
9D-12



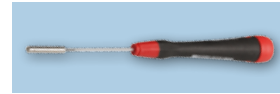
Hex screwdriver
WS 1.5 mm for screws DIN 912, 913, and 914 5M

Order Code
50HD-15



Adjustment tool
for rotating quarter-waveplates in fiber collimators 60FC-Q...

Order Code
60Z-2803



Eccentric tool with longer handle for laser beam couplers 60SMF-... and fiber collimators 60FC-... as an alternative to 60EX-4, 60EX-5, 55EX-5 above

Order Code
60EX-4-L
60EX-5-L
55EX-5-L

Detailed data sheets, up-to-date technical information, technical drawings including step files, accessories, extensive technotes section and FAQs:
www.sukhamburg.com



Multicube Systems

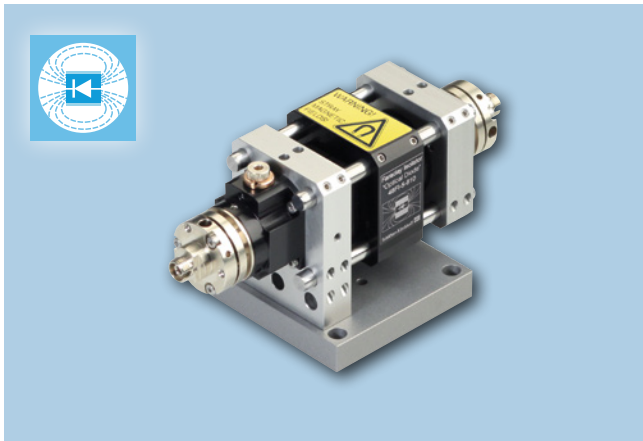
Fiber-coupled Faraday isolator, Fiber-to-Fiber Couplers, Attenuators, Beam Splitters and Combiners

Fiber-coupled Faraday Isolators

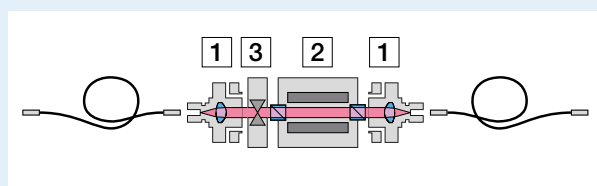
The fiber-to-fiber couplers with Faraday isolator from Schäfter+Kirchhoff suppress back-reflection and also offer – as an option – attenuator and shutter functionalities.

A fiber-to-fiber coupler with Faraday isolator is used to protect laser beam sources where the attached fiber connectors cannot be removed (e.g. a fiber pigtail) or when back-coupling to the fiber is a desirable and discriminating characteristic (e.g. in interferometry). They are used in combination with polarization-maintaining fiber cables.

- High isolation >30 dB
- Low insertion loss <0.5 dB
- Compatibility with multicube™ and microbench / cage systems
- Standard wavelengths in a range of 400 to 1080 nm
- Bandwidth: center wavelength ±20 nm

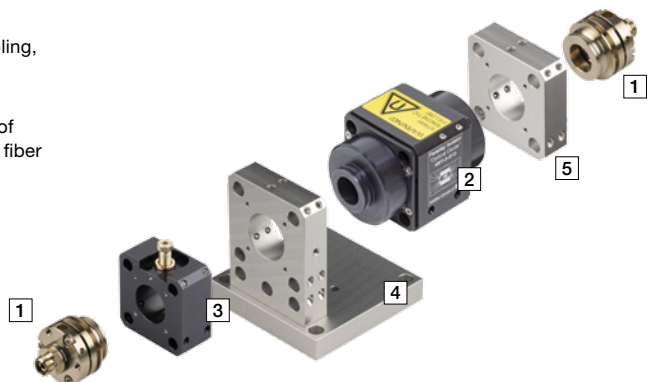


Optical Scheme



Set-up / Order Codes

- | | |
|---|---|
| <p>1 Laser beam coupler
Order Code 60SMF-1-4-</p> <p>2 Faraday isolator
Order Code 48FI-</p> <p>3 Attenuator/Shutter
Order Code 48AT-A/ 48AT-S</p> <p>4 Console
Order Code 48MB-19.5-60</p> <p>5 Mounting Plate
Order Code 48MC-MP-19.5</p> | <p>for out and for in-coupling, adjustable</p> <p>avoids back-coupling of laser radiation into the fiber</p> <p>Option: Attenuator or shutter mechanism</p> |
|---|---|



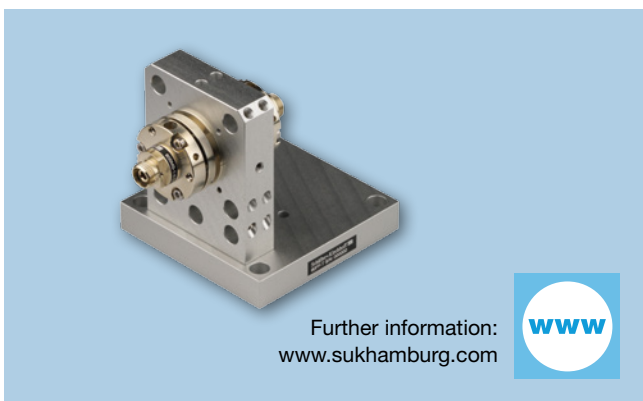
Fiber-Fiber Couplers 60FF, 60FF-T, 60FF-P

for interconnecting two single-mode fibers or polarization-maintaining fibers

The 60FF fiber-fiber couplers are used for interconnecting two fiber cables. They can be aligned and focused so that fiber cables with non-core centered connectors can be coupled with a low coupling loss and, additionally, the polarization axes can be aligned.

The 60FF fiber-fiber couplers are based on two 60SMF laser beam coupler. They can be used with two differing coupling focal length and/or connection types in order to interconnect different types of fibers and/or cables with differing connector types.

For more details see p. 22.



Further information:
www.sukhamburg.com



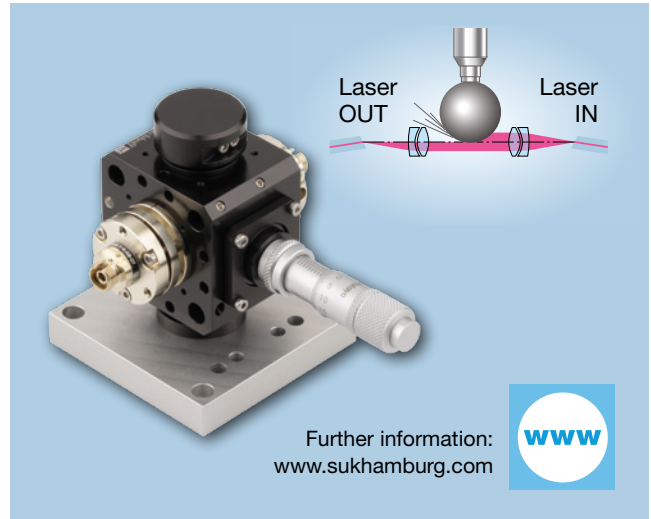
Laser Attenuators 48AT

Fiber-coupled attenuator for reduction of output power

Laser Attenuators 48AT are used for reproducible and precise reduction of the power output by the laser. The collimated laser beam is constricted by a precision ball transported by a scaled micrometer screw. The subsequent single-mode fiber coupling is used as a mode filter.

This mechanically stable attenuation method allows the precise and reproducible setting of the laser power output over a wide range (typically 1.5 to > 60 dB). Unlike a power regulation by modulation of the laser current, the wavelength and polarization status of the laser beam are preserved.

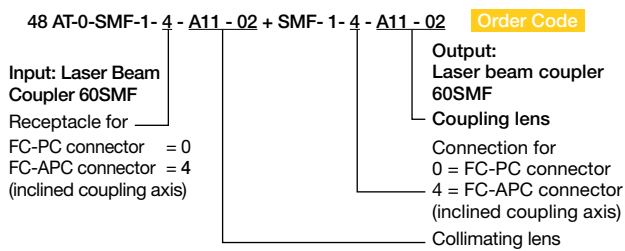
- Reproducible power attenuation are only assured for single-mode fibers that have a Gaussian intensity profile
- For single-moder or PM fiber cables
- Insertion loss typically 1.5 dB, extinction > 60 dB
- Adjustable and compact, rugged, transportable and sealed opto-mechanical units
- Very high long-term stability, efficiency and reproducibility
- Can be used as interface between different types of single-mode fibers or connectors



Further information:
www.sukhamburg.com

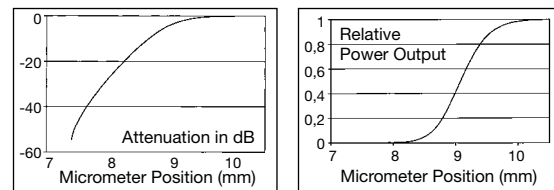


Order options for Laser attenuator 48AT



For choice of Laser Beam Couplers 60SMF, see page 18.

Typical calibration curves



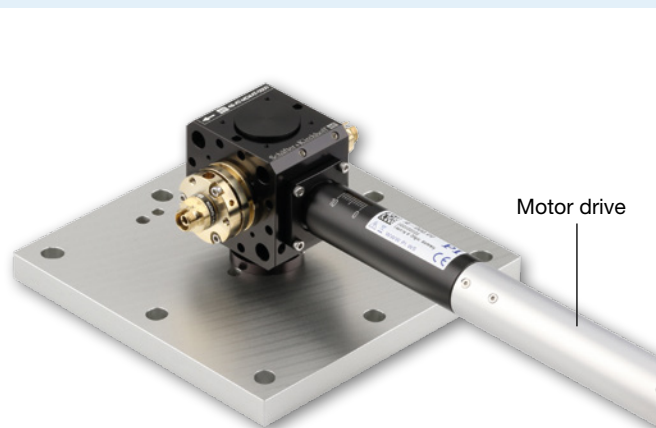
Configurations

48AT-MD with motorized drive

The 48AT-MD motorized laser attenuators are identical with the manual 48AT-0 laser attenuators in all respects, except for the replacement of the manual micrometer screw by a motorized version.

The additional parameters for the motorization are:

- Closed-loop DC motors
- Min. incremental motion down to 0.05 μm
- Max. velocity 2 mm/s
- Limit switch control
- Controllable via USB and RS232 interface
- Macro-programmable stand-alone functionality
- Additional I/O ports
- DLLs and LabVIEW driver
- User software



Order Code 48 AT-MD

For order code details see 48AT-0

Electro-magnetic Laser Shutters 48EMS

fiber-coupled or free beam, compatible with multicube™ system

Fiber-coupled electro-magnetic laser shutter 48EMS-0

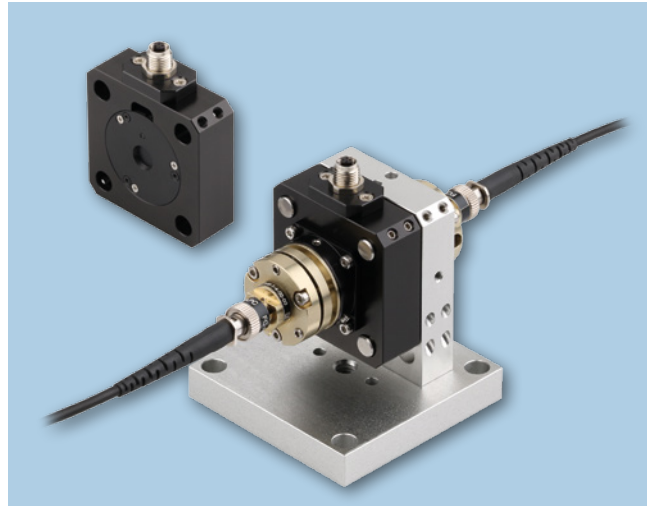
- With single-mode, PM or multimode fiber cables
- Compatible to the multicube™ System
- Bistable, operating frequency max. 15 Hz
- Controlled by TTL signal (flank control)
- Electrical connection type M8, 4 pin female
- Suitable shutter controller SK97121 (not included)
- Compact, rugged, transportable and sealed opto-mechanical units
- Very high long-term stability, efficiency and reproducibility
- Can be used as an interface between different types of fibers or connectors

Electro-magnetic laser shutter 48EMS-6

- Clear aperture 6 mm
- Compatible to the multicube™ System
- Bistable, operating frequency max. 15 Hz
- Controlled by TTL signal (flank control)
- Electrical connection type M8, 4 pin female
- Suitable shutter controller SK97121 (not included)

Please note:

This is not a laser safety shutter according to EN 60825. Additional laser safety measures may be necessary.



Detailed data sheets, up-to-date technical information, technical drawings including step files, accessories, extensive technotes section and FAQs: www.sukhamburg.com



Order Options

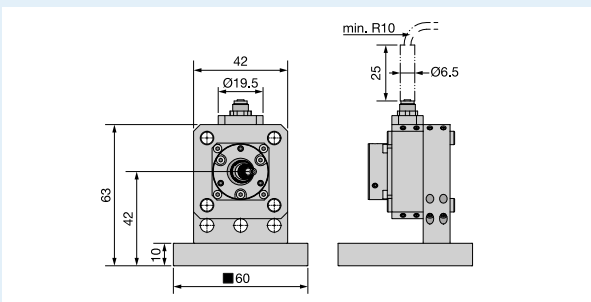
Fiber-coupled electro-magnetic shutter:

Order Code 48EMS-0

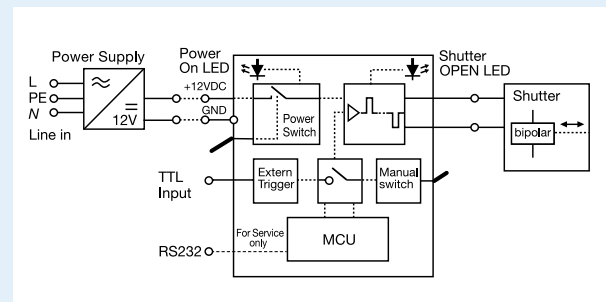
Free beam electro-magnetic shutter:

Order Code 48EMS-6

Dimensions



Electrical scheme



Accessories SK97121C

Shutter control unit SK97121C for electro-magnetic shutters type 48EMS

- Suitable for bi-stable shutter devices
- Operating modes: Manual switch and TTL (BNC)
- Power supply and output cable included



Order Options

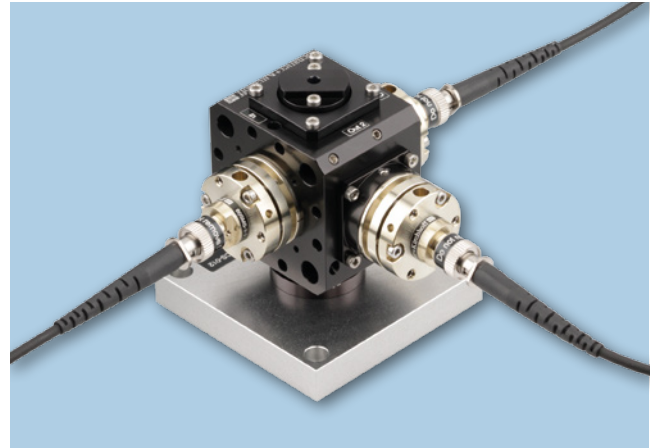
Shutter control

Order Code SK97121C

Beam Splitters

Compact, rugged and highly efficient opto-mechanical unit for splitting fiber coupled radiation

- Based on the multicube™ system
- Configuration 1 → 2 and 2 → 2
- Highly efficient coupling into single-mode or polarization-maintaining fiber cables
- Compact, rugged, transportable and sealed opto-mechanical units
- Fully fiber-coupled
- Very high long-term stability, efficiency and reproducibility



Order Code (Example, more see Table 1)

1 → 2 polarizing splitter Order Code 48-MCS-015

Please additionally specify the wavelength (range).

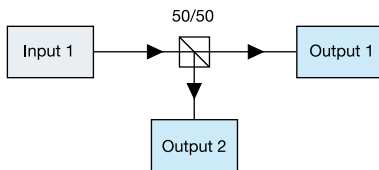
Detailed data sheets, up-to-date technical information, technical drawings including step files, accessories, extensive technotes section and FAQs:
www.sukhamburg.com



Example Configurations

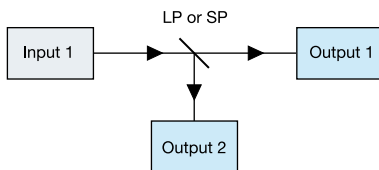
50:50 Beam splitter

A PM-fiber coupled source is split into 2 output fiber cables with a fixed splitting ratio. The radiation is split using a beam splitter cube.



Dichroic Beam splitter

Two fiber-coupled broadband sources or two super-imposed narrow-band sources in one input fiber cable are split into 2 wavelength ranges and then coupled to two output fiber cables by using a dichroic beam splitter (long pass or short pass).



Polarizing Beam Splitter

The radiation guided in the two linear principle states of a polarization-maintaining fiber is split into 2 output PM fiber cables by using a polarizing beam splitter cube that separates s- and p- polarization.

For a better polarization extinction ratio a polarizer is placed in the deflected beam.

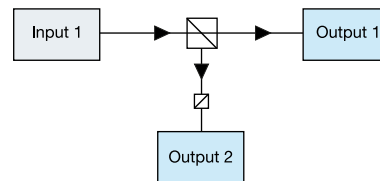


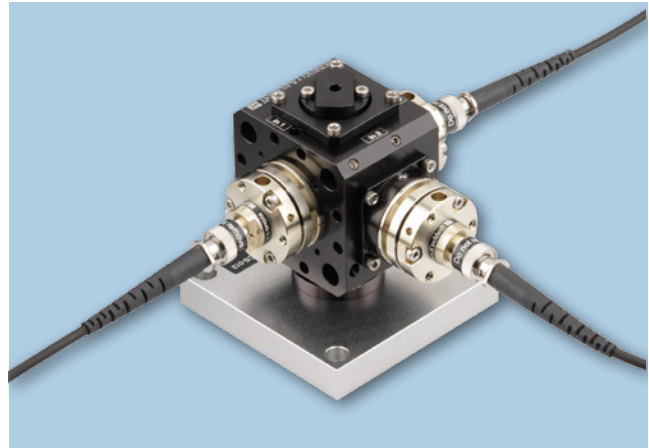
Table 1 Order Options Beam Splitters (Partial selection only. More information on www.sukhamburg.com)

row	Order Code	Configuration	Splitting Ratio	Wavelengths (others on request)	Transmission	Polarization Extinction
1	48-MCS-002	1 → 2	50:50	400 - 1700 nm, monochromatic or bandwidth up to 500 nm	≥ 75 % @ 780 nm	≥ 23 dB @ 780 nm
2	48-MCS-011	1 → 2	dichroic	400 - 1700 nm	≥ 70 % @ 780 nm	≥ 23 dB @ 780 nm
3	48-MCS-015	1 → 2	polarizing	400 - 1700 nm, monochromatic or bandwidth up to 500 nm	≥ 70 % @ 780 nm	≥ 23 dB @ 780 nm
4	48-MCS-027	2 → 2	50:50	400 - 1700 nm, monochromatic or bandwidth up to 500 nm	≥ 75 % @ 780 nm	≥ 23 dB @ 780 nm
5	48-MCS-026	2 → 2	polarizing	400 - 1700 nm, monochromatic or bandwidth up to 500 nm	≥ 70 % @ 780 nm	≥ 23 dB @ 780 nm

Beam Combiners

Compact, rugged and highly efficient opto-mechanical unit for combining fiber coupled radiation

- Based on the multicube™ system
- Configuration 2 → 1 and 2 → 2
- Highly efficient coupling into polarization-maintaining fiber cables
- Compact, rugged, transportable and sealed opto-mechanical units
- Fully fiber-coupled
- Very high long-term stability, efficiency and reproducibility



Order Code (Example, more see Table 2)

2 → 2 polarizing combiner **Order Code** 48-MCS-026

Please additionally specify the wavelength (range).

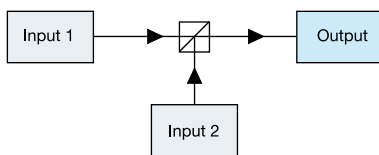
Detailed data sheets, up-to-date technical information, technical drawings including step files, accessories, extensive technotes section and FAQs: www.sukhamburg.com



Example Configurations

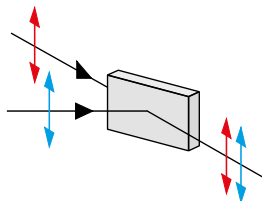
Polarization dependent Beam Combiner

Two PM-fiber coupled sources are combined into one output fiber cable. The radiation is superimposed by using a polarizing beam splitter. I.e. the two sources are superimposed with normal states of polarization..



Dichroic Beam Combiner

Two PM-fiber coupled sources with different wavelength or wavelength ranges are combined into one output fiber cable by using a dichroic beam combiner. This configuration can be used when the wavelength spacing is > 10 nm.



Polarizing Beam Combiner / Splitter 2 → 2

The radiation guided in two PM or single-mode fiber cables is combined in two output fiber cables (PM or single-mode).

The radiation is split using a polarizing beam splitter cube that separates s- from p-polarization and combines s- with p-polarization.

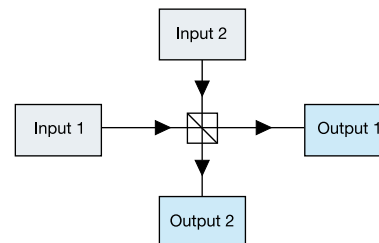


Table 2 **Order Options Beam Combiners** (Partial selection only. More information on www.sukhamburg.com)

row	Order Code	Configuration	Combiner	Wavelengths (others on request)	Transmission	Polarization Extinction
5	48-MCS-008	2 → 1		400 - 1700 nm, monochromatic or bandwidth up to 500 nm	≥ 75 % @ 780 nm	≥ 23 dB @ 780 nm
6	48-MCS-016	2 → 1	dichroic	400 - 1700 nm	≥ 75 % @ 780 nm	≥ 23 dB @ 780 nm
7	48-MCS-026	2 → 2	polarizing	400 - 1700 nm, monochromatic or bandwidth up to 500 nm	≥ 75 % @ 780 nm	≥ 23 dB @ 780 nm

Laser Beam Combiners 48RGB / 48RGBV

Systems for combination of (405), 460, 532 and 660 nm laser radiation into a single fiber-coupled beam

The laser beam combiner type 48RGB/48RGBV takes three or four different fiber-coupled beams (each in a polarization-maintaining single-mode fiber), and combines them into a single output that is then coupled into a single polarization-maintaining fiber. The modular system combines up to four wavelengths in the 400–660 nm range. The individual laser power sources for each wavelength can be attenuated separately so that any desired power relationship can be obtained.

The beams are superimposed by using appropriate dichroics each with a 0.3°-wedge profile to avoid interference from back-reflected light (Etalon effect). The propagation through parallel plates causes a beam offset, which is corrected by a compensatory axial displacement of the laser beam couplers.

An attenuator allows adjustment of the combined laser output.

The tilt adjustment and focusing mechanism of the laser beam couplers, as well as the tilt adjustment of the

dichroics, provide all of the degrees of freedom needed for alignment.

The combiner shows all the benefits of a system based on the multicube™/ fiber port cluster system including compact, robust design as well as very high stability, efficiency and reproducibility. It is delivered fully assembled and pre-aligned with polarization-maintaining fiber cables for both input and output ports.

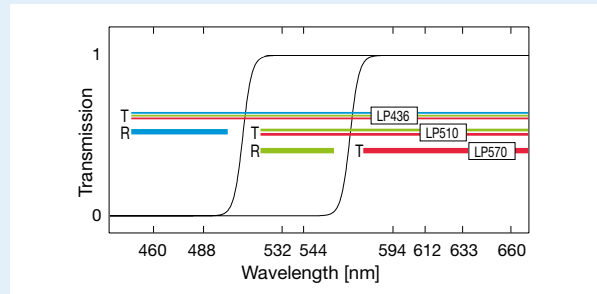
- Systems for combination of 405, 460, 532 and 660 nm laser radiation into a single fiber-coupled beam
- Apochromatically corrected RGBV Laser Beam Coupler
- Long-pass (LP) broad transmission band for cascaded use of various long-pass filters (with transmission reaching 95 % and reflection up to 99 %)
- Fused silica substrates with 0.3°-wedge angle for suppressing interference
- Inclined coupling axes to avoid back-reflection

3→1 Laser Beam Combiners 48RGB

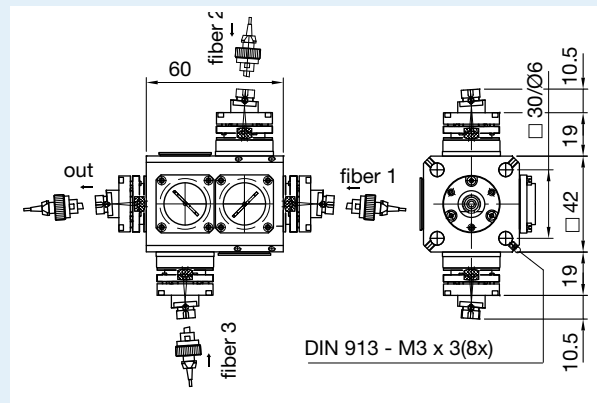


- Combination of three different wavelengths in the spectral range of 400–660 nm
- Two dichroics for superposition

Transmission Spectra of Beam Combiners RGB, (Example)



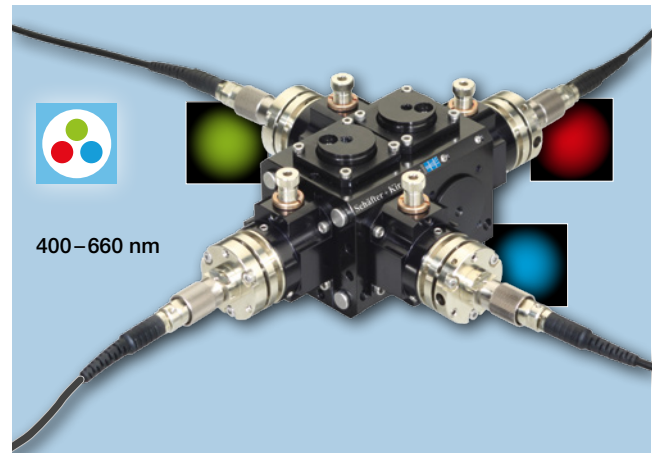
Dimensions



Order Code

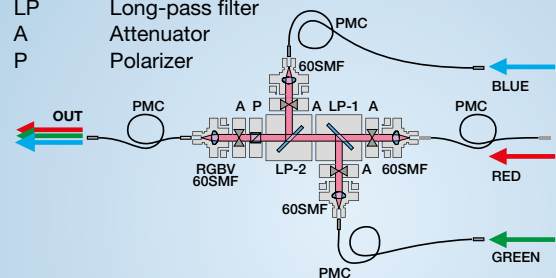
3 → 1 RGB Laser Beam Combiner

Order Code 48RGB



Optical Scheme

- RGBV 60SMF Laser beam coupler with apochromatic optics
- 60SMF Laser beam coupler
- PMC PM-fiber cable
- LP Long-pass filter
- A Attenuator
- P Polarizer

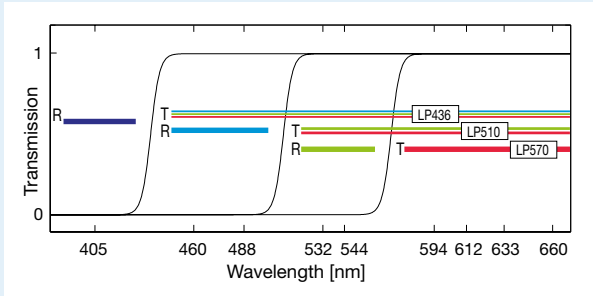


4 → 1 Laser Beam Combiners 48RGBV

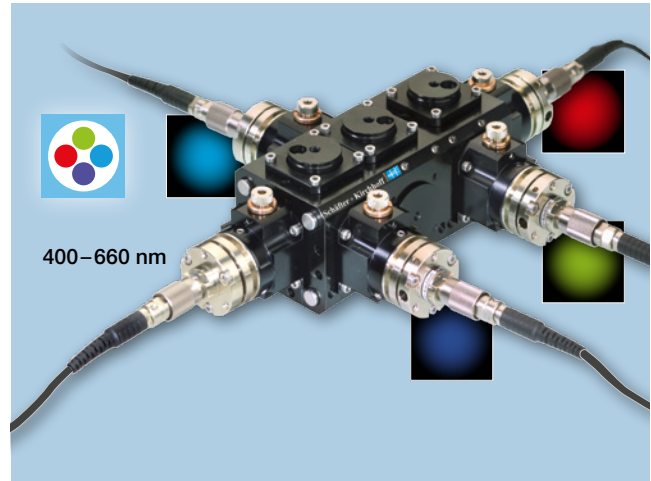
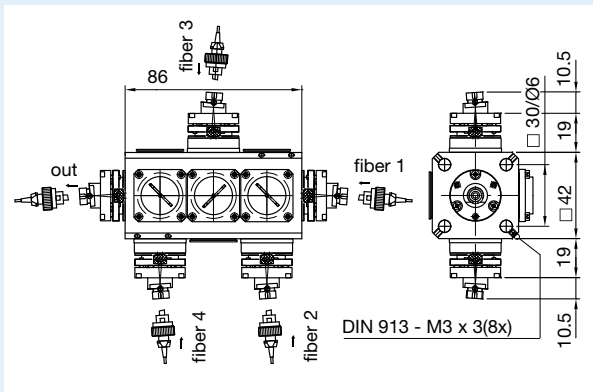


- Combination of four different wavelengths in the spectral range of 400–660 nm
- Three dichroics for superposition

Transmission Spectra of Beam Combiners RGBV (Example)



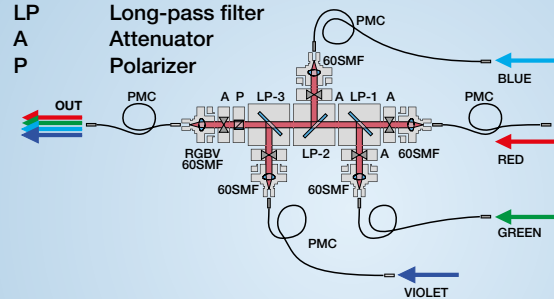
Dimensions



Optical Scheme

RGBV Laser beam coupler with apochromatic optics 60SMF

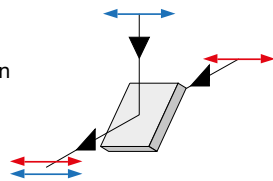
- 60SMF Laser beam coupler
- PMC PM fiber cable
- LP Long-pass filter
- A Attenuator
- P Polarizer



Optical scheme for 48BC-CC-LP beam combiner

Application:

with s-polarization optimization:
for all linear states of polarization
perpendicular to the plane of
incidence



Beam Combiner / Long Pass

Spectral range	Reflection	Transmission
	99 %	95%
436 nm	370 - 412	460 - 700
510 nm	405 - 488	532 - 660
570 nm	532 - 544	594 - 660

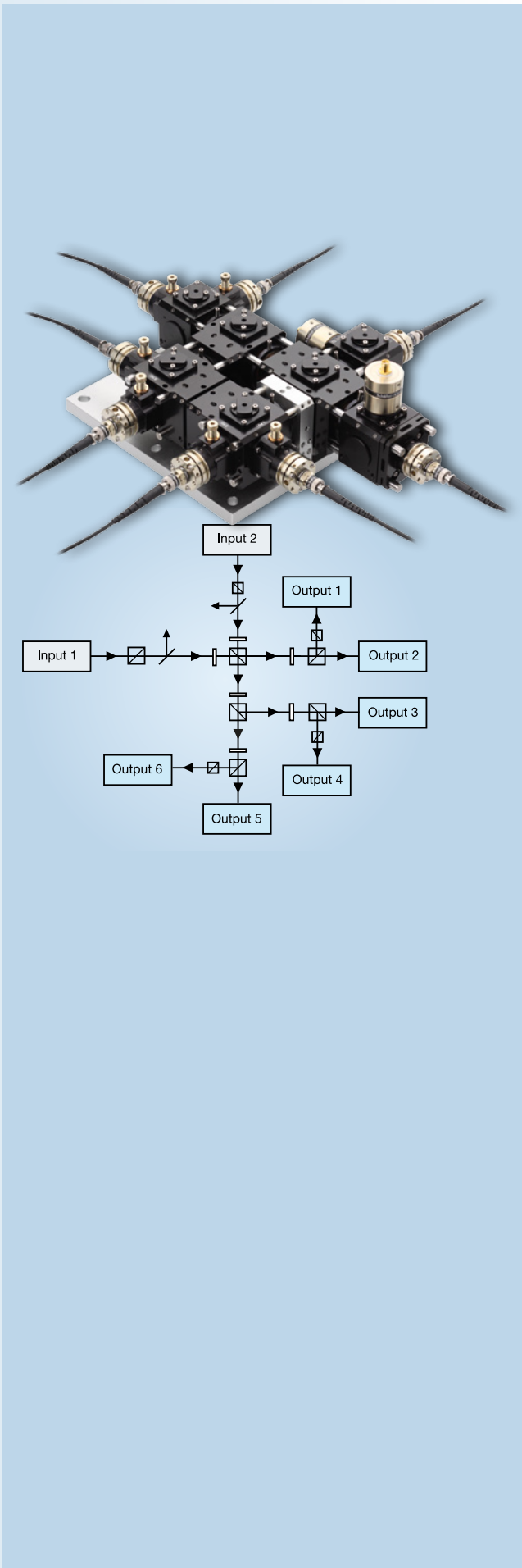
Others on request.

Order Code

4 → 1 RGBV Laser Beam Combiner **Order Code** 48RGBV

Fiber Port Cluster

Fiber Port Clusters:
Compact, rugged and highly
efficient opto-mechanical
units for splitting/combining
multiple ports



■ Fiber Port Clusters

Fiber Port Clusters 90

Example:

Fiber Port Clusters 2→6 91

Example:

Dichroic Fiber Port Clusters 92

Order Options 93

Fiber Port Cluster

Compact, rugged and highly efficient opto-mechanical units for splitting/combining multiple ports

Fiber port clusters are compact opto-mechanical units that split or combine the radiation from one or more polarization-maintaining (PM) fiber cables into one or multiple output polarization-maintaining fiber cables with high efficiency and variable splitting ratio.

They are often used for quantum optics experiments. They are compact and sealed and replace large breadboard setups. Because of the polarization dependent properties of the optical components within the fiber port cluster, PM fibers are used to transport the light to the cluster with defined linear polarization.

Main features:

- Compact, rugged, transportable and sealed opto-mechanical units fully fiber-coupled
- Very high stability, efficiency and reproducibility
- For beam splitting and beam combination – separated from the laser source by using fiber optics
- Large variety of multicube™ components to produce a wide range of possible systems
- Multiple configurations: e.g. 1→2, 2→2, 1→3 ... up to 2→6 or 2→8
- Highly efficient coupling into polarization-maintaining fiber cables
- Variable splitting / combination ratio
- Dichroic configurations for different wavelengths possible

Optical Setup

The input ports are fiber coupled to PM fiber cables. Polarizers define the input polarization which is necessary for a long term stable splitting ratio.

Photo diodes right after each input port allow for a continuous monitoring of the radiation. The input sources are superimposed by means of a polarization beam splitter.

Subsequently, the radiation splitting is achieved by using a cascade of rotary half-wave plates in combination with polarization beam splitters. By use of the rotary half-wave plates, almost any desired splitting ratio can be achieved.

At the output ports further polarizers are placed in order to define the radiation at output of the system.

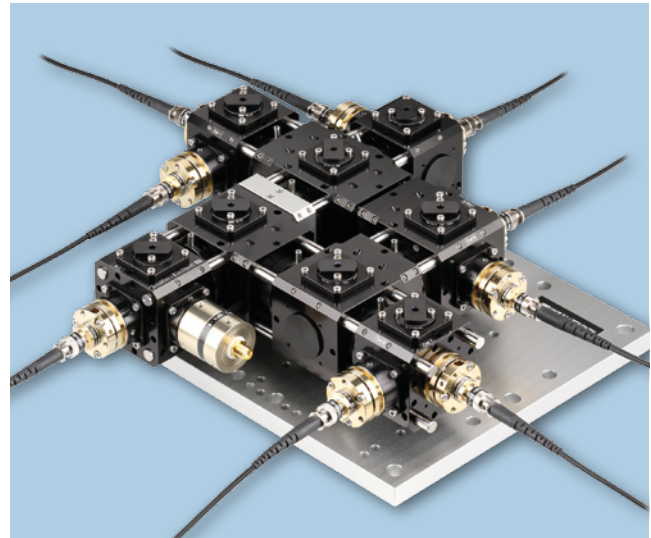
If using several inputs with multiple wavelengths, the wavelength difference between the input ports determines how the combination can best be achieved – for details see p. 92.

Fiber Couplers

A fundamental component of a Fiber Port Cluster is the Laser Beam Coupler, which is the input into the opto-mechanical unit collimating the input radiation and, finally, couples the radiation back into the polarization-maintaining fiber cables. The stability of the total Fiber Port Cluster is determined by the stability of the stability of the laser beam coupler. (For details see p. 15, 17ff.)

Why use fiber optics?

Many experiments require an extremely stable setup. Fiber optics can serve as a defined interface between a laser source and the more sensitive environment of the experiment. A physical separation between these parts of the setup enables a mechanical and thermal decoupling, avoiding any negative mutual impacts.



Detailed data sheets, up-to-date technical information, technical drawings including step files, accessories, extensive technotes section and FAQs: www.sukhamburg.com



Delivery

The fiber port cluster is delivered fully assembled and pre-aligned, together with highly detailed manuals, should further adjustment be desired.

Example:

Fiber Port Clusters in Micro-Gravity Experiments



The compactness and ruggedness of Schäfter+Kirchhoff fiber port clusters has been rigorously demonstrated in the micro-gravity environment of parabolic flights.

- 1 vacuum chamber 3 fiber port cluster
2 fiber collimator

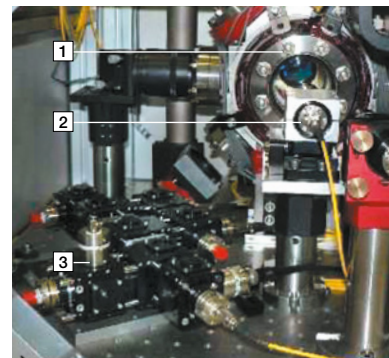


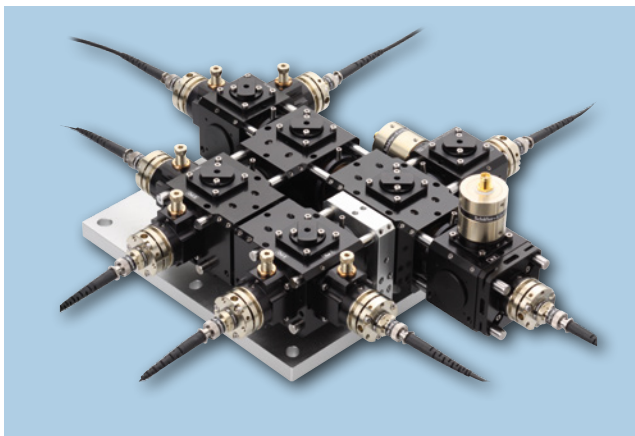
Figure obtained from arXiv: 0705.2922v2 [physics.atom-ph]

Example: Fiber Port Clusters 2→6 48-FPC-2-6-xxx

Fiber-coupled 2→6 beam delivery system with 2 input ports and 6 output ports

This Fiber Port Clusters 2 → 6 is a compact opto-mechanical unit that combines two fiber-coupled sources with same wavelengths and then splits the combined radiation into 6 output fiber cables with high efficiency and variable splitting ratio.

- Configuration 2 → 6
- Highly efficient coupling into polarization-maintaining fiber cables
- Adjustable splitting ratio
- Compact, rugged, transportable and sealed opto-mechanical units
- Fully fiber-coupled
- Very high long-term stability, efficiency and reproducibility



Detailed data sheets, up-to-date technical information, technical drawings including step files, accessories, extensive technotes section and FAQs:
www.sukhamburg.com



Examples for Fiber Port Clusters for MOTs for typical isotopes include:

Designed for Isotope	Sr	Yb	Na	Li	Sr	Na	K	Rb	Kr	Cs	He
Wavelength	461	556	589	671	689	760	767	780	811	852	1083

Optical Setup

This Fiber Port Clusters 2 → 6 is a compact opto-mechanical unit that combines two fiber-coupled sources with same wavelengths and then splits the combined radiation into 6 output fiber cables with high efficiency and variable splitting ratio.

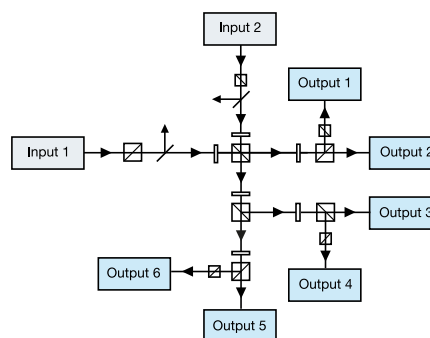
The two input ports are fiber-coupled to PM fiber cables. Polarizers define the input polarization which is necessary for a long term stable splitting ratio.

Two photo diodes right after each input port allow for a continuous monitoring of the radiation. The two input sources are superimposed by means of a polarization beam splitter.

Subsequently, the radiation splitting is achieved by using a cascade of rotary half-wave plates in combination with polarization beam splitters. By use of the rotary half-wave plates, almost any desired splitting ratio can be achieved.

At the output ports further polarizers are placed in order to define the radiation at output of the system.

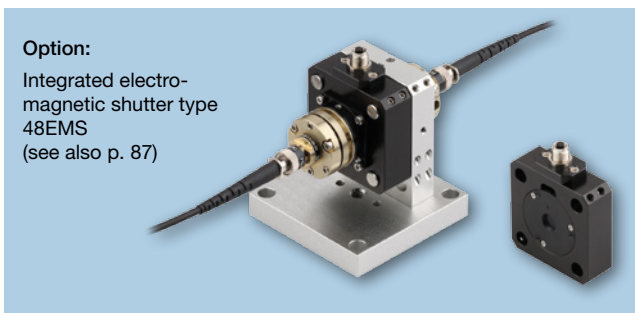
An additional attenuator at each output port allows for a fine-balancing. The fiber cables have a polarization-maintainance of more than 26 dB (at 780 nm) and have fiber connectors of type FC-APC for suppressing back-reflections.



Order Options for Fiber Port Clusters type 48-FPC

- Order Code** 48-FPC-2-6-xxx
- Wavelength(s)
 - Number of output ports
 - If dichroic: Add lp (long pass)
 dc (dichroic wave plate)
 - Number of input ports

Option:
 Integrated electro-magnetic shutter type 48EMS (see also p. 87)

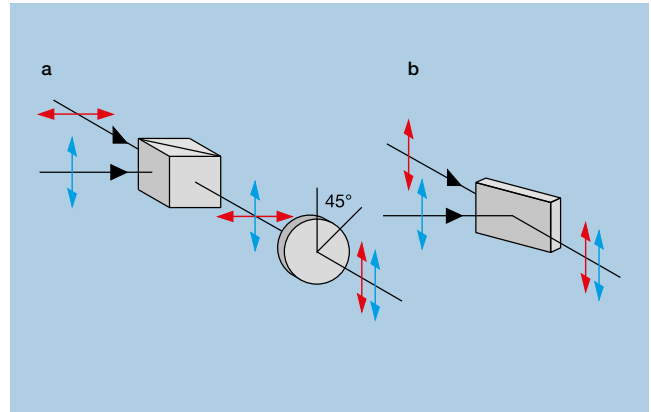


Examples: Dichroic Fiber Port Clusters

It is also possible to combine beams of different wavelengths at the input port of a Fiber Port Cluster for the subsequent splitting of both components equally. In these dual-wavelength systems, laser beam couplers with achromatically or even apochromatically corrected optics are used to obtain coupling efficiencies as high as those of a monochromatic system.

- Small wavelength difference, **Type 48FC-x-x_dc-xxx**: polarization beam splitter in combination with a dichroic wave plate (a),
- Large wavelength difference, **Type 48FC-x-x_lp-xxx**: superposition using a dichroic mirror (b)
- Highly efficient coupling into polarization-maintaining fiber cables
- Adjustable splitting ratio
- Compact, rugged, transportable and sealed opto-mechanical units
- Fully fiber-coupled
- Very high long-term stability, efficiency and reproducibility

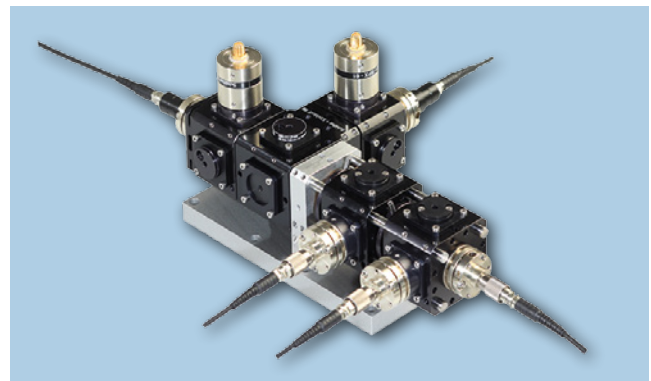
If the wavelength difference of the two lasers is too large for guiding in a common single-mode fiber, there are specially developed fiber collimators with an integrated dichroic beam combiner that have two separate input connections for the two sources (see p. 45).



Example: Fiber Port Clusters 2 → 3 – 48-FPC-2-3_lp-xxx

Fiber Port Cluster for two input sources with differing wavelength and with three output ports.

- Configuration 2 → 3 long pass
- Superposition by means of a dichroic mirror
- Highly efficient coupling into polarization-maintaining fiber cables
- Adjustable splitting ratio
- Compact, rugged, transportable and sealed opto-mechanical units
- Fully fiber-coupled
- Very high long-term stability, efficiency and reproducibility



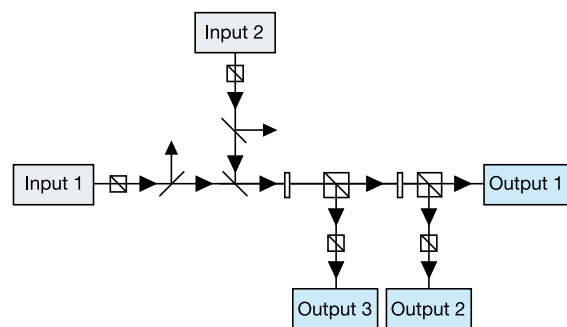
Optical Setup

The two input ports are fiber coupled to PM fiber cables. Polarizers define the input polarization which is necessary for a long term stable splitting ratio.

Two photo diodes right after each input port allow for a continuous monitoring of the radiation. The two differing input sources are superimposed by means of a dichroic mirror (long pass).

Subsequently, the radiation splitting is achieved by using a cascade of rotary half-wave plates in combination with polarization beam splitters. By use of the rotary half-wave plates, almost any desired splitting ratio can be achieved.

At the output ports further polarizers are placed in order to define the radiation at output of the system.



Order Options for Fiber Port Clusters type 48-FPC

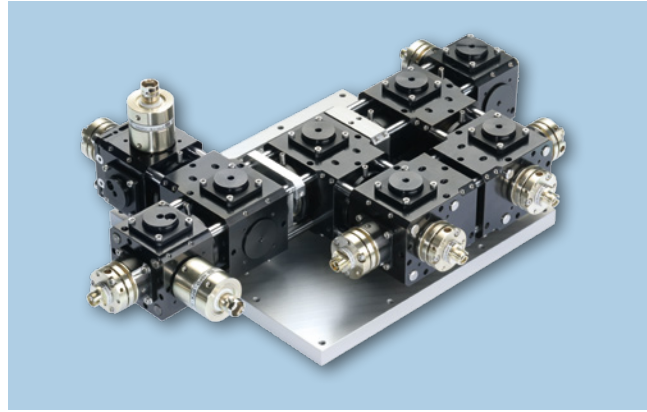
Order Code 48-FPC-2-3_lp-xxx+xxx

Wavelength 1 + Wavelength 2 (see Table 1)

Example: Fiber Port Clusters 2→6 – 48-FPC-2-6_dc-xxx

Fiber Port Cluster for two input sources with differing wavelength and with 6 output ports.

- Configuration 2 → 6 dichroic
- Superposition by means of a polarization beam splitting cube and a dichroic wave plate
- Highly efficient coupling into polarization-maintaining fiber cables
- Adjustable splitting ratio
- Compact, rugged, transportable and sealed opto-mechanical units
- Fully fiber-coupled
- Very high long-term stability, efficiency and reproducibility



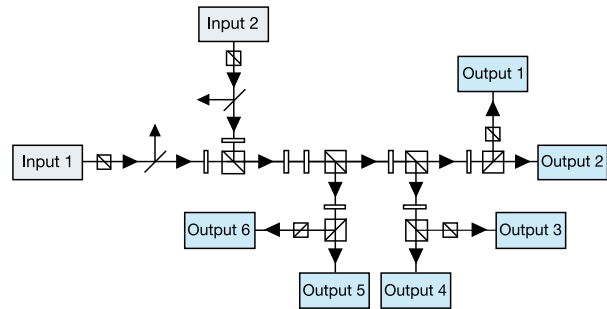
Optical Setup

The two input ports are fiber coupled to PM fiber cables. Polarizers define the input polarization which is necessary for a long term stable splitting ratio.

Two photo diodes right after each input port allow for a continuous monitoring of the radiation. The two differing input sources are superimposed by means of polarization beam splitting cube. A dichroic wave plate rotates the two orthogonally polarized input beams of different wavelengths into linear polarization states in parallel.

Subsequently, the radiation splitting is achieved by using a cascade of rotary half-wave plates in combination with polarization beam splitters. By use of the rotary half-wave plates, almost any desired splitting ratio can be achieved.

At the output ports further polarizers are placed in order to define the radiation at output of the system.



Order Options for Fiber Port Clusters type 48-FPC

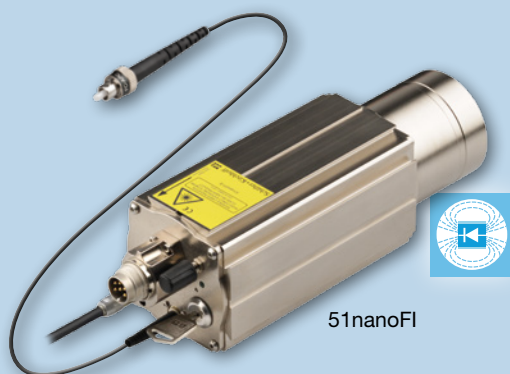
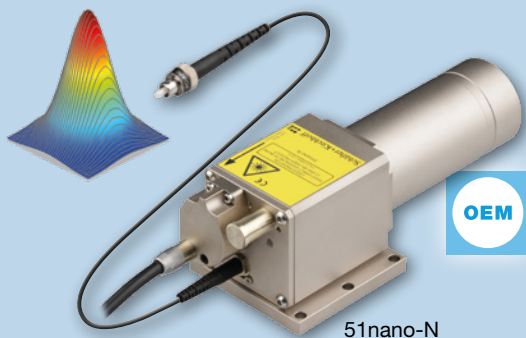
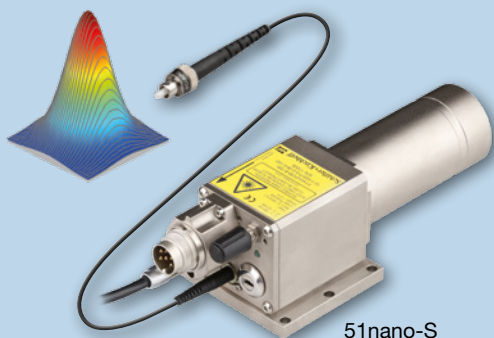
Order Code 48-FPC-2-6_dc-xxx+xxx _____ Wavelength 1 + Wavelength 2 (see Table 1)

Table 1 Order Options for Fiber Port Clusters (Partial selection only. More information on www.sukhamburg.com)

row	Order Code	Configuration	Dichroic	Wavelengths (others on request)
Configurations 1 → x				
1	48-FPC-1-2-xxx	1 → 2	-	523 and 780 nm
2	48-FPC-1-3-xxx	1 → 3	-	461, 689, 767, 780 and 852 nm
3	48-FPC-1-4-xxx	1 → 4	-	461, 532, 671, 780 and 852 nm
4	48-FPC-1-6-xxx	1 → 6	-	461, 556, 589, 626, 767, 780 and 852 nm
5	48-FPC-1-8-xxx	1 → 8	-	461, 556, 589, 626, 767, 780 and 852 nm
Configurations 2 → x				
5	48-FPC-2-3_n-xxx	2 → 3 n	-	689, 780, and 852 nm
6	48-FPC-2-4-xxx	2 → 4	-	689 and 780 nm
7	48-FPC-2-6-xxx	2 → 6	-	589, 671, 767, 773, 780, 852 nm
Configurations 2 → x, dichroic				
8	48-FPC-2-3_lp-xxx	2 → 3 lp	long pass	399 + 556, 403 + 461, 780 + 852 nm
9	48-FPC-2-3_dc-xxx	2 → 3 dc	dichroic	767 + 780 nm
10	48-FPC-2-6_lp-xxx	2 → 6 lp	long pass	461 + 689 nm
11	48-FPC-2-6_dc-xxx	2 → 6 dc	dichroic	767 + 780 nm

Low Coherence

**Fiber-Coupled Low Coherence
Laser Sources with reduced
speckle contrast, reduced
coherence length and low noise**



■ Fiber-Coupled Low Coherence Laser Sources

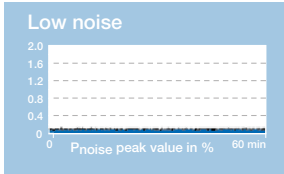
Fundamentals	96
Overview	97
Laser Diode Beam Sources 51nano-S	98
Laser Diode Beam Sources 51nano-N	99
Laser Diode Beam Sources 51nanoFI-S	100
Laser Diode Beam Sources 51nanoFI-N	101
Special configuration: 51nanoC-S with Multiple Output Ports	102
Electronics and Accessories	103



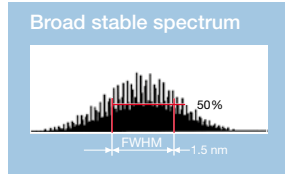
Low Coherence Laser

The laser diode beam sources of type 51nano are fiber-coupled laser-sources developed for low noise, low coherence length and reduced speckle contrast. The laser to run free of „mode-hopping“. The low noise (typ. $< 0.15\%$ of P_o (RMS, Bandwidth < 1 MHz)) depends on the laser diode within the module. Some lasers show even less noise with typ. $< 0.1\%$ of P_o (RMS, Bandwidth < 1 MHz). The series includes the lasers type 51nano and 51nano-FI with integrated Faraday isolator for increased stability in the case of back-reflected light.

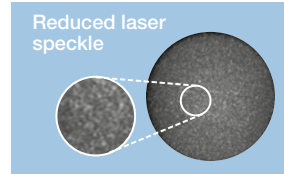
Characteristics of laser beam source of type 51nano compared with a standard laser diode beam source



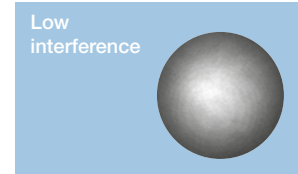
With RF modulation, mean laser power is constant with noise typ. $< 0.15\%$ of P_o (RMS, Bandwidth < 1 MHz).



Broadened spectrum (~ 1.5 nm FWHM) with reduced coherence length (~ 0.3 mm) as a result of RF modulation. No mode hopping occurs.

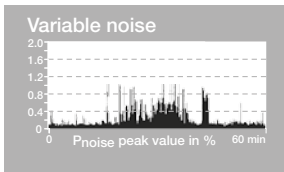


Low speckle contrast from reduced coherence length: uniform illumination of 4-quadrant diodes with improved position detection, e.g., in AFM.

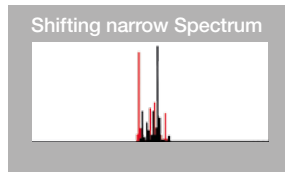


The Gaussian intensity distribution of the collimated laser beam on a flat camera sensor. Despite the sensor protection window, there are no interference patterns.

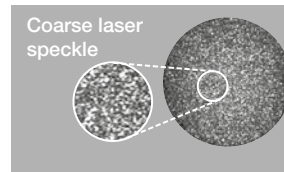
Characteristics of standard laser diode sources



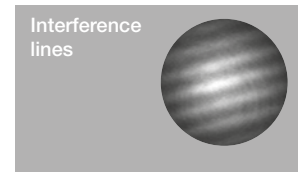
Stochastic power noise resulting from, for example, an external cavity between the laser diode and its fiber coupling.



Mode hopping: temporal shifts between modes. The coherence length changes over time. It can be > 1 m.



The laser spot produced by a standard laser diode beam produces a speckle pattern, increasing the statistical uncertainty in position determinations.



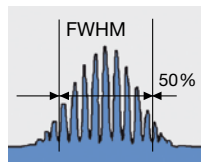
Collimated laser beam recorded directly using a flat camera sensor, with its protection window generating a disturbing pattern of interference.

Faraday Isolator

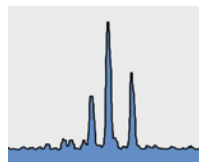


The Faraday isolator is used to protect laser sources from back-reflection (optical diode).

Radiation reflected back into a laser diode leads to mode hopping, noise, frequency instability and decrease in laser lifetime.



Spectrum of an undisturbed laser beam source 51nano



Back-reflections disturb spectrum (mode hopping)



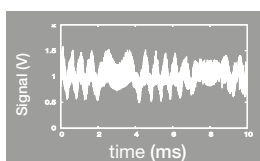
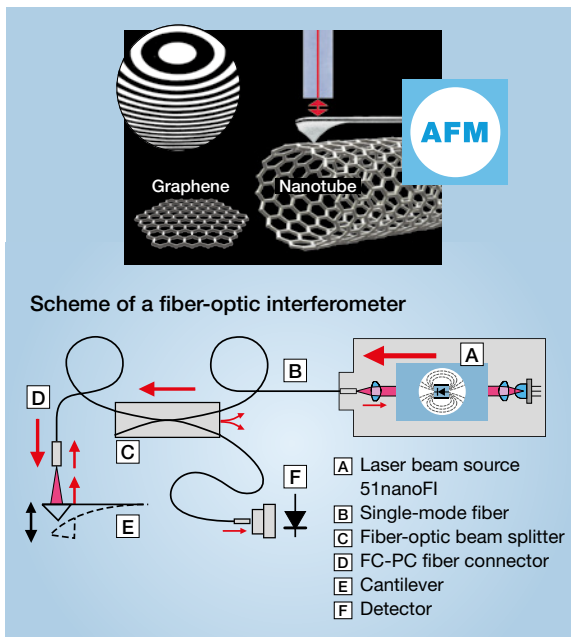
Overview Laser Diode Beam Sources of Type 51nano

Features	51nano-S	51nano-N	51nanoFI-S	51nanoFI-N	51nanoC-S
Image					
Reduced coherence	x	x	x	x	x
Reduced noise	x	x	x	x	x
Low speckle contrast	x	x	x	x	x
Faraday isolator			x	x	
OEM version		x		x	
Wavelength range [nm]	405-1550	405-1550	405-1550	405-1550	460-1550
Vacuum feed-through	x	x	x	x	-
Supply Voltage	5V/12V	5V/12V	5V/12V	5V/12V	5V/12V
Page	100	100	101	102	103

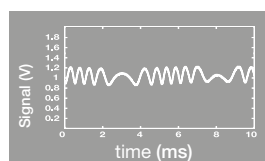
Application: Fabry-Perot Interferometry

The light emitted from the fiber is partially back-reflected at the fiber end facette (approx. 4%) and is reflected by a cantilever.

These two waves interfere. The reduced coherence length of the 51nano offers an advantage because the disturbing interference is suppressed and only interference between the surfaces of interest contribute to the signal.



Standard Laser Diode:
Interferences disturb the signal

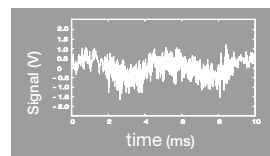
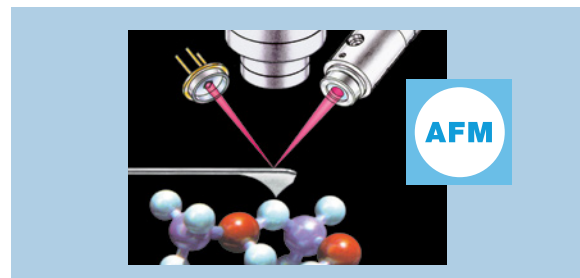


Signal with 51nanoFI:
No disturbing interferences

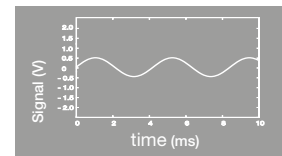
Application: Laser Deflection Measurement

The deflection of the cantilever is measured sensitively using a laser spot reflected from the top surface of the cantilever onto a quadrant diode.

The 51nano used as the laser source avoids disturbing interferences from the back-scattered light of the sample.

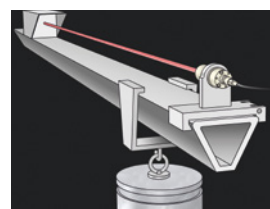


Standard Laser Diode:
Interferences disturb the signal

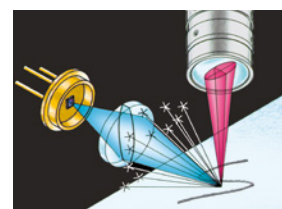


Signal with 51nano
No disturbing interferences

Further Applications



Laser for Adjustment and Alignment



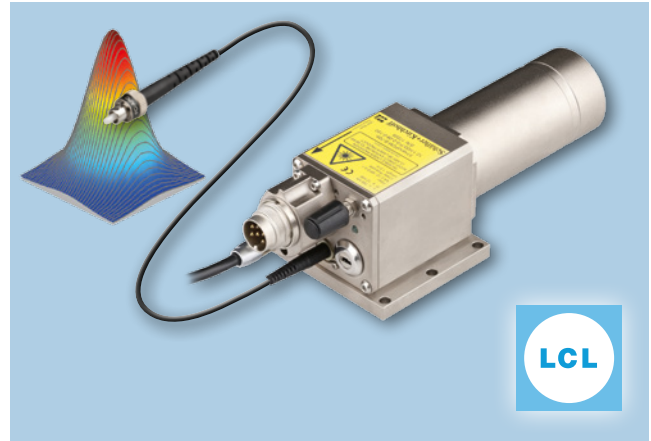
Scratch Detector

Fiber-Coupled Low-Coherence Laser Sources 51nano-S

Laser diode beam sources with single-mode or polarization-maintaining single-mode fiber cable

Laser Diode Beam Sources of type 51nano-S have reduced power noise, reduced coherence length and a lowered speckle contrast.

- Reduced power noise: typ. <math> < 0.15\% </math> of P_o (RMS, Bandwidth <math> < 1 </math> MHz)
- Reduced coherence length: Coherence length $\approx 300 \mu\text{m}$
- Reduced speckle contrast
- Various wavelengths from 375 nm to 1550 nm
- Laser output power up to 30 mW
- Single-mode or polarization-maintaining fiber cable (Polarization Extinction Ratio PER $\geq 23 \text{ dB}$ (for $\lambda < 600 \text{ nm}$ $\geq 21 \text{ dB}$))
- FC APC connector (8°-polish), optional AVIM (comp. with LSA) or E-2000, end caps for wavelengths <math> < 635 \text{ nm}</math>
- Modulation analog and TTL, see p.103
- With interlock and key switch (conform to EN 60825)
- Beam profile is rotationally symmetric with Gaussian intensity distribution



Detailed data sheets, up-to-date technical information, technical drawings including step files, accessories, extensive technotes section and FAQs: www.sukhamburg.com



Table 1 Order Options for Lasers Type 51nano-S (Partial selection only. More on www.sukhamburg.com)

Cur. No.	Series	Wavelength (nm)	P _{out} (mW)*	Laser diode code	LD operation mode	Supply power (V)	Electr. connection	Fiber type	Fiber connector option	Fiber length (cm)	Electr. type	NAe ^{2**}	End cap	Power adjustment %
row	column	1	2	3	4	5	6	7	8	9	10	11	12	13
1	51nano-S	375	10	X23	P	12	HP	0.078	x	<10 - 100
2	51nano-S	405	14	M29	P	12	HP	0.071	x	<10 - 100
3	51nano-S	445	17	G02	P	12	HP	0.063	x	<10 - 100
4	51nano-S	520	7	O11	P	12	HP	0.061	x	<10 - 100
5	51nano-S	640	17	H21	P	5	H	0.078	-	<1 - 100
6	51nano-S	660	28	H26	P	5	H	0.076	-	<1 - 100
7	51nano-S	785	12	Q06	P	5	H	0.078	-	<1 - 100
8	51nano-S	850	18	G17	P	5	H	0.076	-	<1 - 100
9	51nano-S	905	18	Q13	P	5	H	0.074	-	<1 - 100
10	51nano-S	980	2	TH4	P	5	H	0.081	-	<1 - 100
11	51nano-S	1064	10	Q05	P	5	H	0.079	-	<1 - 100
12	51nano-S	1310	2	M14	P	5	H	0.077	-	<1 - 100
13	51nano-S	1550	2	Q04	P	5	H	0.077	-	<1 - 100

Order Code

51nano-S - 640 - 17 - H21 - P - 5 - 2 - 28 - 0 - 150

Laser diode operation mode:
Constant power..... P

Electrical cable:
1.5 m shielded 3 x 0.14 mm² 1
as for 1, with connector type Lumberg SV30 (5V) ... 2
as for 1, with connector type Lumberg SV40 (12V) ... 4
specified by customer..... 5

Length of fiber cable in cm (standard = 150)

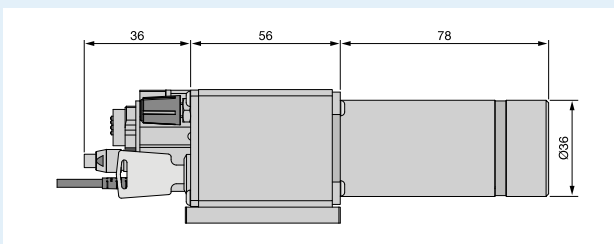
Connector option:
0 = standard
C = core-alignment (single-mode only)

Fiber type: all with strain-relief and protective sleeving (Ø 3 mm)
18 = single-mode fiber cable, FC-APC connector (8°-polish)
28 = PM single-mode fiber cable, FC-APC connector (8°-polish)

optional:
• Fiber connector AVIM (comp. with LSA) and E-2000.
• Incorporated vacuum feed-through

* Typical laser output power. The actual power output may differ by $\pm 10\%$. Lasers with reduced power (reduced laser safety class) on request.
** Typical value for PM fiber. May differ by $\pm 10\%$. Measured value is provided with the data sheet of the end product.

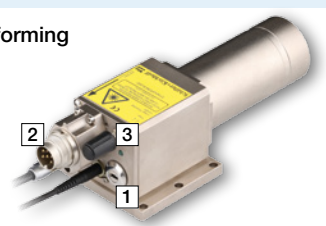
Dimensions: 51nano-S



Laser safety measures

Laser safety measures conforming to IEC 825 / EN 60825-1:

- Key switch [1]
- LED indicator for laser operation
- Interlock connection [2]
- Potentiometer for reduction of power output [3]

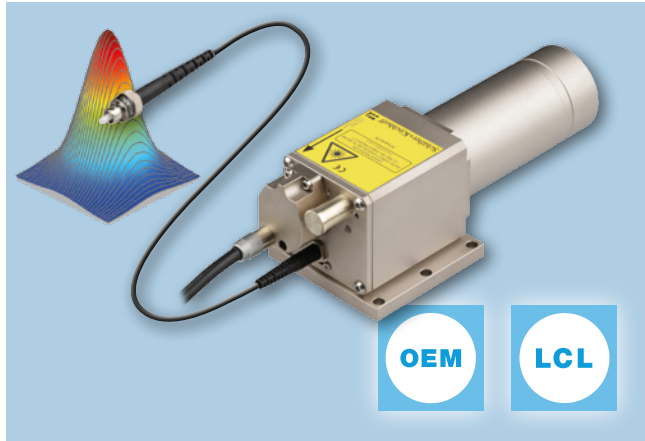


Fiber-Coupled Low-Coherence Laser Sources 51nano-N

Laser diode beam sources with single-mode or polarization-maintaining single-mode fiber cable

Laser Diode Beam Sources of type 51nano-N have reduced power noise, reduced coherence length and a lowered speckle contrast.

- OEM version without key switch nor interlock and not conforming to EN 60825-1
- Reduced power noise: typ. 0.15% of P_o (RMS, Bandwidth <math><1\text{ MHz}</math>)
- Reduced coherence length: Coherence length $\approx 300\text{ }\mu\text{m}$
- Reduced speckle contrast
- Various wavelengths from 375 nm to 1550 nm
- Laser output power up to 30mW
- Single-mode or polarization-maintaining fiber cable (Polarization Extinction Ratio PER $\geq 23\text{ dB}$ (for $\lambda < 600\text{ nm}$) $\geq 21\text{ dB}$)
- FC APC connector (8°-polish), optional AVIM (comp. with LSA) or E-2000, end caps for wavelengths <math><635\text{ nm}</math>
- Modulation analog and TTL, see p.103
- Beam profile is rotationally symmetric with Gaussian intensity distribution



Detailed data sheets, up-to-date technical information, technical drawings including step files, accessories, extensive technotes section and FAQs: www.sukhamburg.com



Fiber-Coupled Low Coherence Laser Sources

Table 2 Order Options for Lasers Type 51 nano-N (Partial selection only. More on www.sukhamburg.com)

Cur. No.	Series	Wavelength (nm)	P _{out} (mW)*	Laser diode code	LD operation mode	Supply power (V)	Electr. connection	Fiber type	Fiber connector option	Fiber length (cm)	Electr. type	NAe ^{2**}	End cap	Power adjustment %
row	column	1	2	3	4	5	6	7	8	9	10	11	12	13
1	51nano-N	375	10	X23	P	12	HP	0.078	x	<10 - 100
2	51nano-N	405	14	M29	P	12	HP	0.071	x	<10 - 100
3	51nano-N	445	17	G02	P	12	HP	0.063	x	<10 - 100
4	51nano-N	520	7	O11	P	12	HP	0.061	x	<10 - 100
5	51nano-N	640	17	H21	P	5	H	0.078	-	<1 - 100
6	51nano-N	660	28	H26	P	5	H	0.076	-	<1 - 100
7	51nano-N	785	12	Q06	P	5	H	0.078	-	<1 - 100
8	51nano-N	850	18	G17	P	5	H	0.076	-	<1 - 100
9	51nano-N	905	18	Q13	P	5	H	0.074	-	<1 - 100
10	51nano-N	980	2	TH4	P	5	H	0.081	-	<1 - 100
11	51nano-N	1064	10	Q05	P	5	H	0.079	-	<1 - 100
12	51nano-S	1310	2	M14	P	5	H	0.077	-	<1 - 100
13	51nano-S	1550	2	Q04	P	5	H	0.077	-	<1 - 100

Order Code

51nano-N - 640 - 17 - H21 - P - 5 - 2 - 28 - 0 - 150

Laser diode operation mode:
Constant power: P

Electrical cable:
1.5 m shielded 3 x 0.14 mm² 1
as for 1, with connector SV30 (5V) 2
as for 1, with connector SV40 (12V). 4
specified by customer 5

Length of fiber cable in cm (standard = 150)

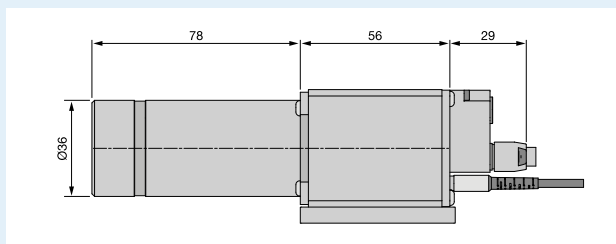
Connector option:
0 = standard
C = core-alignment (single-mode only)

Fiber type: all with strain-relief and protective sleeving (Ø 3mm)
18 = single-mode fiber cable, FC-APC connector (8°-polish)
28 = PM single-mode fiber cable, FC-APC connector (8°-polish)

optional:
• Fiber connector AVIM (comp. with LSA) and E-2000.
• Incorporated vacuum feed-through

* Typical laser output power. The actual power output may differ by $\pm 10\%$. Lasers with reduced power (reduced laser safety class) on request.
** Typical value for PM fiber. May differ by $\pm 10\%$. Measured value is provided with the data sheet of the end product.

Dimensions: 51 nano-N



OEM Laser

OEM version without key switch nor interlock and not conforming to EN 60825-1.



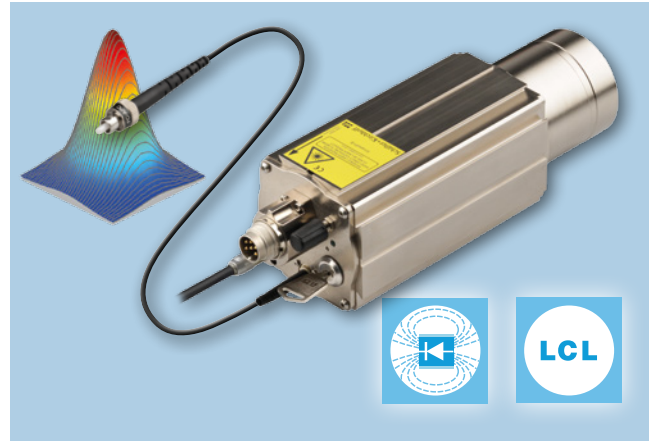
Additional safety measures need to be provided by the customer.

Fiber-Coupled Low-Coherence Laser Sources 51nanoFI-S

Laser diode beam source with single-mode or PM-fiber cable and Faraday isolator

Laser Diode Beam Sources of type 51nanoFI-S have reduced power noise, reduced coherence length and a lowered speckle contrast.

- Integrated Faraday isolator for feedback protection (> 30 dB)
- Reduced power noise: typ. <0.15 % of Po (RMS, Bandwidth <1 MHz)
- Reduced coherence length: Coherence length ≈300 μm
- Reduced speckle contrast
- Various wavelengths from 405 nm to 1550 nm
- Laser output power up to 27 mW
- Polarization-maintaining fiber cable (Polarization Extinction Ratio PER ≥23 dB (for λ < 600 nm ≥ 21 dB))
- FC APC connector (8°-polish), optional AVIM (comp. with LSA) or E-2000, end caps for wavelengths <635 nm
- Modulation analog and TTL, see p.103
- With interlock and key switch (conform to EN 60825-1)
- Beam profile is rotationally symmetric with Gaussian intensity distribution



Detailed data sheets, up-to-date technical information, technical drawings including step files, accessories, extensive technotes section and FAQs: www.sukhamburg.com



Table 3 Order Options for Lasers Type 51nanoFI-S (Partial selection only. More on www.sukhamburg.com)

Cur. No.	Series	Wave-length (nm)	P _{out} (mW)*	Laser diode code	LD operation mode	Supply power (V)	Electr. connection	Fiber type	Fiber connector option	Fiber length (cm)	Casing	Electr. type	NAe ^{2**}	End cap	Power adjustment %
row	column	1	2	3	4	5	6	7	8	9	10	11	12	13	14
1	51nanoFI-S	405	12	M29	P	12	S1	HP	0.071	x	<10 - 100
2	51nanoFI-S	445	15	G02	P	12	S1	HP	0.063	x	<10 - 100
3	51nanoFI-S	520	6	O11	P	12	S1	HP	0.061	x	<10 - 100
4	51nanoFI-S	640	15	H21	P	5	S1	H	0.078	-	<1 - 100
5	51nanoFI-S	660	25	H26	P	5	S1	H	0.076	-	<1 - 100
6	51nanoFI-S	785	10	Q06	P	5	S2	H	0.078	-	<1 - 100
7	51nanoFI-S	850	15	G17	P	5	S1	H	0.076	-	<1 - 100
8	51nanoFI-S	1064	8	Q05	P	5	S2	H	0.079	-	<1 - 100
9	51nanoFI-S	1310	2	M14	P	5	S1	H	0.077	-	<1 - 100
10	51nanoFI-S	1550	4	Q04	P	5	S1	H	0.077	-	<1 - 100

51nanoFI-S - 640 - 15 - H21 - P - 5 - 2 - 28 - 0 - 150 Order Code

Laser diode operation mode:
Constant power..... P

Electrical cable:
1.5 m shielded 3 x 0.14 mm² 1
as for 1, with connector SV30 (5V) 2
as for 1, with connector SV40 (12V) 4
specified by customer 5

Length of fiber cable in cm (standard = 150)
Connector option:
0 = standard
C = core-alignment (single-mode only)

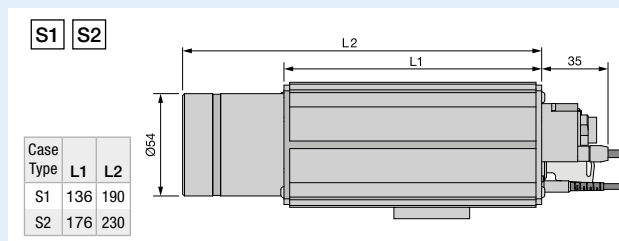
Fiber type: all with strain-relief and protective sleeving (Ø3 mm)
18 = single-mode fiber cable, FC-APC connector (8°-polish)
28 = PM single-mode fiber cable, FC-APC connector (8°-polish)

* Typical laser output power. The actual power output may differ by ±10 %.
Lasers with reduced power (reduced laser safety class) on request.

** Typical value for PM fiber. May differ by ±10 %. Measured value is provided with the data sheet of the end product.

- optional:
- Fiber connector AVIM (comp. with LSA) and E-2000.
 - Incorporated vacuum feed-through

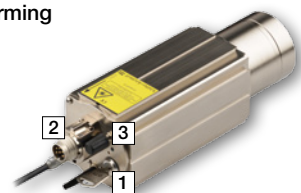
Dimensions: 51nanoFI-S



Laser safety measures

Laser safety measures conforming to IEC 825 / EN 60825-1:

- Key switch [1]
- LED indicator for laser operation
- Interlock connection [2]
- Potentiometer for reduction of power output [3]

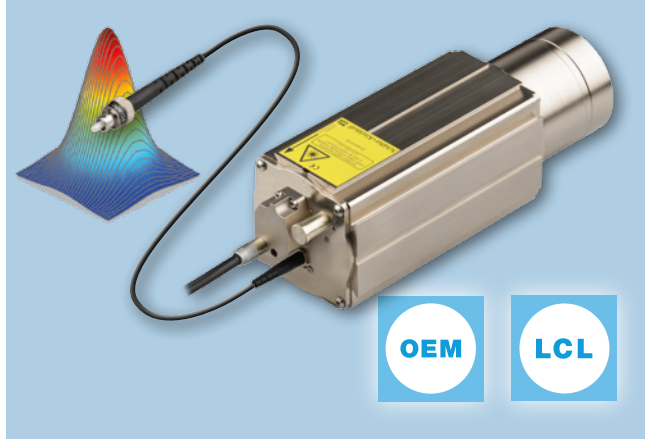


Fiber-Coupled Low-Coherence Laser Sources 51nanoFI-N

Laser diode beam source with single-mode or PM-fiber cable and Faraday isolator

Laser Diode Beam Sources of type 51nanoFI-S have reduced power noise, reduced coherence length and a lowered speckle contrast.

- OEM version without key switch nor interlock and not conforming to EN 60825-1
- Integrated Faraday isolator for feedback protection (>30 dB)
- Reduced power noise: typ. <0.15 % of Po (RMS, Bandwidth <1 MHz)
- Reduced coherence length: Coherence length ≈300 μm
- Reduced speckle contrast
- Various wavelengths from 405 nm to 1550 nm
- Laser output power up to 27 mW
- Polarization-maintaining fiber cable (Polarization Extinction Ratio PER ≥23 dB (for λ < 600 nm ≥ 21 dB))
- FC APC connector (8°-polish), optional AVIM(comp. with LSA) or E-2000, end caps for wavelengths < 635 nm
- Modulation analog and TTL, see p.103
- Beam profile is rotationally symmetric with Gaussian intensity distribution



Detailed data sheets, up-to-date technical information, technical drawings including step files, accessories, extensive technotes section and FAQs:
www.sukhamburg.com



Fiber-Coupled Low Coherence Laser Sources

Table 4 Order Options for Lasers Type 51nanoFI-S (Partial selection only. More on www.sukhamburg.com)

Cur. No.	Series	Wave-length (nm)	P _{out} (mW)*	Laser diode code	LD operation mode	Supply power (V)	Electr. connection	Fiber type	Fiber connector option	Fiber length (cm)	Casing	Electr. type	NAe ^{2**}	End cap	Power adjustment %
row	column	1	2	3	4	5	6	7	8	9	10	11	12	13	14
1	51nanoFI-N	405	12	M29	P	12	N1	HP	0.071	x	<10 - 100
2	51nanoFI-N	445	15	G02	P	12	N1	HP	0.063	x	<10 - 100
3	51nanoFI-N	520	6	O11	P	12	N1	HP	0.061	x	<10 - 100
4	51nanoFI-N	640	15	H21	P	5	N1	H	0.078	-	<1 - 100
5	51nanoFI-N	660	25	H26	P	5	N1	H	0.076	-	<1 - 100
6	51nanoFI-N	785	10	Q06	P	5	N2	H	0.078	-	<1 - 100
7	51nanoFI-N	850	15	G17	P	5	N1	H	0.076	-	<1 - 100
8	51nanoFI-N	1064	8	Q05	P	5	N2	H	0.079	-	<1 - 100
9	51nanoFI-N	1310	2	M14	P	5	N1	H	0.077	-	<1 - 100
10	51nanoFI-N	1550	4	Q04	P	5	N1	H	0.077	-	<1 - 100

51nanoFI-N - 640 - 15 - H21 - P - 5 - 2 - 28 - 0 - 150 Order Code

Laser diode operation mode:
 Constant power P

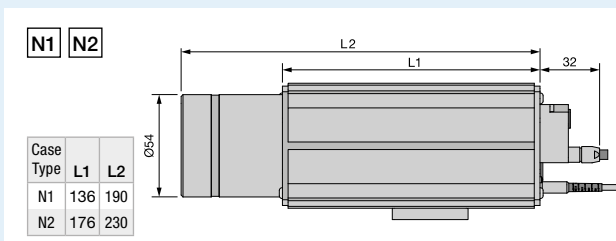
Electrical cable:
 1.5 m shielded 3 x 0.14 mm² 1
 as for 1, with connector SV30 (5V) 2
 as for 1, with connector SV40 (12V) 4
 specified by customer 5

Length of fiber cable in cm (standard = 150)
 Connector option:
 0 = standard
 C = core-alignment (single-mode only)

Fiber type: all with strain-relief and protective sleeving (Ø3 mm)
 18 = single-mode fiber cable, FC-APC connector (8°-polish)
 28 = PM single-mode fiber cable, FC-APC connector (8°-polish)

optional: • Fiber connector AVIM (comp. with LSA) and E-2000.
 • Incorporated vacuum feed-through

Dimensions: 51nanoFI-N



OEM Laser

OEM version without key switch nor interlock and not conforming to EN 60825-1.



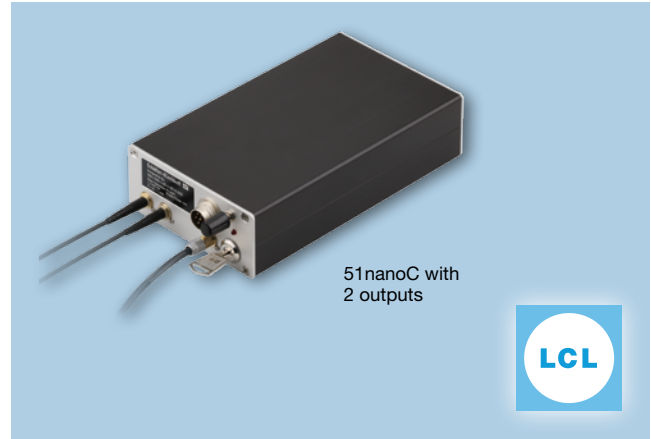
Additional safety measures need to be provided by the customer.

51 nanoC-S: Low Coherence Fiber-coupled Laser Sources

with multiple Fiber Outputs

51 nanoC has all the benefits of a standard 51 nano, but has an integrated beam splitter for a multiple fiber output.

- Single-mode fiber cables
- Number of output ports 2, 3 or 4
- FC APC connector (8°-polish), optional AVIM or E-2000, end caps for wavelengths < 635 nm
- Modulation analog and TTL, see p.103
- With interlock and key switch (conform to EN 60825-1)
- Beam profile is rotationally symmetric with Gaussian intensity distribution



Detailed data sheets, up-to-date technical information, technical drawings including step files, accessories, extensive technotes section and FAQs: www.sukhamburg.com



Table 1 Order Options for Lasers Type 51 nanoC-S (Partial selection only. More on www.sukhamburg.com)

Cur. No.	Series	No of Output Ports x	Wave-length (nm)	P _{out} (mW)*	Laser diode code	LD operation mode	Supply power (V)	Electr. connection	Fiber type	Fiber connector option	Fiber length (cm)	Electr. type	NAe ^{2**}	End cap	Power adjustment %
row	column	1	2	3	4	5	6	7	8	9	10	11	12	13	14
1	51 nanoC-S	2, 3 or 4	520	6	O11	P	12	HP	0.061	x	<10 - 100
2	51 nanoC-S	2, 3 or 4	640	15	H21	P	5	H	0.078	-	<1 - 100
3	51 nanoC-S	2, 3 or 4	660	25	H26	P	5	H	0.076	-	<1 - 100
4	51 nanoC-S	2, 3 or 4	785	12	Q06	P	5	H	0.078	-	<1 - 100
5	51 nanoC-S	2, 3 or 4	850	15	G17	P	5	H	0.076	-	<1 - 100
6	51 nanoC-S	2, 3 or 4	905	18	Q13	P	5	H	0.074	-	<1 - 100
7	51 nanoC-S	2, 3 or 4	980	1.7	TH4	P	5	H	0.081	-	<1 - 100
8	51 nanoC-S	2, 3 or 4	1064	8	Q05	P	5	H	0.079	-	<1 - 100
9	51 nanoC-S	2, 3 or 4	1310	2	M14	P	5	H	0.077	-	<1 - 100
10	51 nanoC-S	2, 3 or 4	1550	4	Q04	P	5	H	0.077	-	<1 - 100

Order Code

51 nanoC-S - x - 640 - 17 - H21 - P - 5 - 2 - 18 - 0 - 150

Number of outputs: x

Laser diode operation mode: Constant power: P

Electrical cable: 1.5 m shielded 3 x 0.14 mm²: 1 as for 1, with connector SV30 (5V): 2 as for 1, with connector SV40 (12V): 4 specified by customer: 5

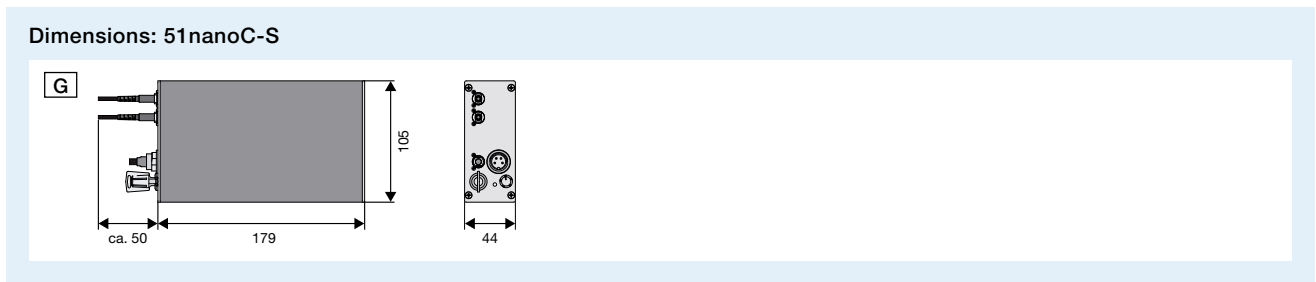
Length of fiber cable in cm (standard = 150): 150

Connector option: 0 = standard, C = core-alignment (single-mode only)

Fiber type: all with strain-relief and protective sleeving (Ø3 mm). 18 = single-mode fiber cable, FC-APC connector (8°-polish)

optional: Fiber connector AVIM (comp. with LSA) and E-2000.

* Sum of all output ports combined. Typical laser output power. The actual power output may differ by ±10 %. Balancing is symmetrical, ± 5 %. Lasers with reduced power (reduced laser safety class) on request.
 ** Typical value. May differ by ±10 %. Measured value is provided with the data sheet of the end product.



Electronics and Accessories Laser Beam Sources Type 51 nano

Electrical Data 51nano and 51nanoFI

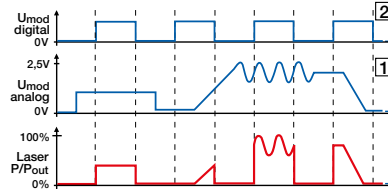
		Electronics Type H	Electronics Type HP
Supply voltage	standard	5V DC (± 0.2 V)	12V DC (± 0.5 V)
Laser diode operation mode		constant power	constant power
Max. operating current *		260 mA	260 mA
Max. modulation frequency	analog	100 kHz	1 Hz
	TTL	100 kHz	300 kHz
Laser power output potentiometer		<1–100%	<10–100%
TTL modulation logic: TTL high		Laser ON	Laser ON
TTL or analog input: open or low		Laser OFF	Laser OFF
Analog control voltage P_{min} to P_{max}		0–2.5 V	0–2.5 V

* Typical value. Depends on laser diode.

Timing Diagram

Modulation: The laser has two AND-wired modulation input channels, U_{analog} [1] and U_{TTL} [2]. The laser is OFF when the modulation input is open. The laser can be modulated digitally. If only one modulation input is used then the other has to be set to +5V (see timing diagram).

The voltage U_{analog} at analog modulation input [1] linearly controls laser output power between $\leq 1\%$ and 100% of the optical power set by the potentiometer.



Accessories

Laser Type	51nano-S / 51nano-FI-S		51nano-N / 51nano-FI-N	
	H	HP	H	HP
Supply voltage	5 V	12	5 V	12 V
Power Supply	PS051003E	PS120516E	PS051003E	PS120516E
Switchbox	-	-	SBN 040401	SBN 040402
Interlock Connectors / connectors for ext. modulation	B0106F-iLCK (part of delivery) The interlock pins are bridged. BC0106F		-	
Connectors for electrical cable type Lumberg SVxx for custom power supplies	BC0109F	BC0104F	BC0109F	BC0104F

Connectors

For 51nano-S / 51nanoFI-S

Lumberg connector (female) according to IEC 61076-2-106

Type KV 60 (6-pin) for connection to interlock chain and for external modulation

The interlock pins are bridged. (Part of delivery)

Order Code BC0106F-iLCK



For 51nano / 51nanoFI

Lumberg connector (female) according to IEC 61076-2-106

Type KV 60 (6-pin) for connection to interlock chain and for external modulation

Order Code BC0106F



For 51nano (Electronics Type H)

Lumberg connector (female) according to IEC 61076-2-106

Type KV 50 (5-pin) for connection of a custom power supply

Order Code BC0109F



For 51nano (Electronics Type HP)

Lumberg connector (female) according to IEC 61076-2-106

Type KV 40 (4-pin) for connection of a custom power supply

Order Code BC0104F



Power Supplies / Switchbox

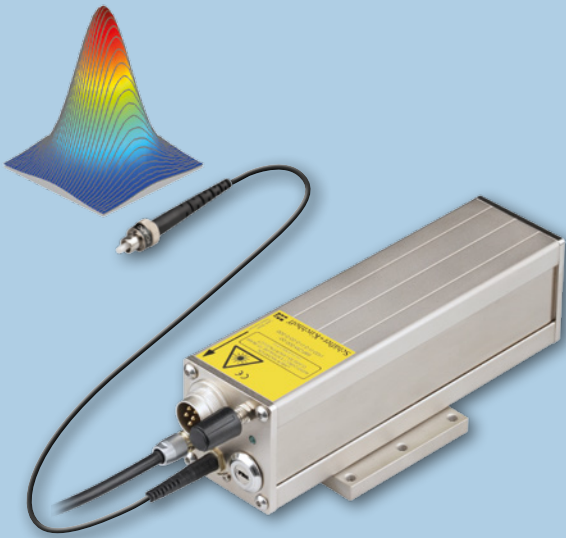
Power supply for laser diode beam sources, electrically isolated, 1.5 m cable with connector (IEC60130-9) Lumberg series KV (female).



	Switching power supply	
Input	100–240 V AC	
Output with connector	5V DC/2.6A BC0103F	12V DC/1.25A BC0104F
Description	Switching power supply, connector (female 5-pin) KV50 for 5 V (pins compatible with KV30) or 4-pin KV40 for 12 V DC version	
for Electronics Type	H	HP
Order Code	PS051003E	PS120516E
	Switchbox (51nano-N / 51nanoFI-N only)	
Description	Reverse voltage protection, key switch, "Laser ON" LED, grounding connector, two modulation inputs (BNC), interlock/ input/output acc. IEC 61076-2-106 acc60130-9	
for Electronics Type	H	HP
Order Code	SBN 050501	SBN 040402

Fiber-Coupled Lasers

**Fiber-Coupled Laser
Sources with single-mode
or polarization-maintaining
fiber cables**



■ Fiber-Coupled Laser Sources

Laser Diode Beam Sources 58FCM —————→ 106

Fiber Coupling Sets for HeNe Lasers —————→ 108

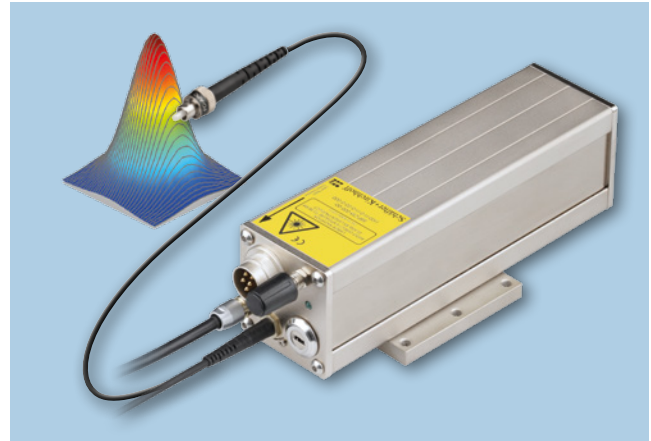
Fiber Coupling Sets with
integrated Faraday Isolators —————→ 110

Laser Diode Beam Source 58FCM

Fiber-coupled laser source with single-mode or polarization-maintaining fiber cables

Laser diode beam sources of type 58FCM are fiber-coupled laser sources with single-mode or polarization-maintaining fiber cables

- Various wavelengths from 405 nm to 1550 nm
- Laser output power up to 70 mW
- Output power adjustable with potentiometer or external voltage control input
- Operation mode: constant power (standard) or constant current
- Beam profile is rotationally symmetric with Gaussian intensity distribution
- Modulation inputs for analog and TTL control (up to 100 kHz), details page 109
- Single-mode fiber cable or polarization-maintaining fiber cable (polarization extinction ratio >23 dB)
- FC-APC connector (8°-polish), optional AVIM (comp. with LSA), or E-2000, end caps for wavelengths <635 nm
- Fiber cable with strain-relief and protect. sleeving (Ø 3mm)
- Laser safety measures conforming to IEC 825 / EN 60825-1 (details page 107)



Options:

- To fulfill lower laser safety requirements (e.g. laser class 2), the laser source can be delivered with reduced maximum output power
- Supply voltage 5 V DC (standard) or 12 V DC (some with 12 V DC only), reverse voltage protection
- Protective cap to prevent damage to the potentiometer

Table 1 Order Options for Laser Diode Beam Source 58nanoFCM

Cur. No.	Type	Wavelength (nm)	P _{out} * (mW)	Laser diode code	LD operation mode**	Supply power (V)	Electronics Type	Electr. connection	Fiber type	Fiber connec. option	Fiber length (cm)	MFD*** (µm)	Fiber end cap
row		1	2	3	4	5	6	7	8	9	10	11	12
1	58FCM	405	40	M29	P/C	5/12	P	3.8	x
2	58FCM	635	1	H01	P/C	5/12	C	5.5	-
3	58FCM	637	5	H10	P/C	5/12	C	5.7	-
4	58FCM	640	25	H22	P/C	5/12	C	5.8	-
5	58FCM	660	14	M01	P/C	5/12	C	6.0	-
6	58FCM	660	24	M26	P/C	5/12	C	6.0	-
7	58FCM	660	70	M25	P/C	5/12	P	6.2	-
8	58FCM	675	3	H03	P/C	5/12	C	6.7	-
9	58FCM	685	24	H13	P/C	5/12	C	7.2	-
10	58FCM	785	23	H06	P/C	5/12	C	9.3	-
11	58FCM	830	18	H19	P/C	5/12	C	9.2	-
12	58FCM	980	6	W22	P/C	5/12	C	10.9	-
13	58FCM	1080	28	EY10	P/C	5/12	C	7.6	-
14	58FCM	1310	2.4	M06	P/C	5/12	C	9.2	-
15	58FCM	1550	2	M15	P/C	5/12	C	10.9	-

58FCM - 637 - 5 - H10 - P - 5 - C - 2 - 28 - 0 - 150 **Order Code**

Laser diode beam source (see Table 1)

Laser diode operation mode:
 constant power (standard) P
 constant current C

Supply voltage:
 5 V DC (standard) 5
 12 V DC 12

Electronics Type (see Table 6):
 The electronics type depends on the laser diode.
 Details about types C and P are found in table of electrical data, see opposite side

Electrical cable
 1.5 m shielded 3 x 0.14 mm² 1
 as for 1, with connector SV30 (5 V) 2
 as for 1, with connector SV40 (12 V) 4
 cable length specified by customer 5

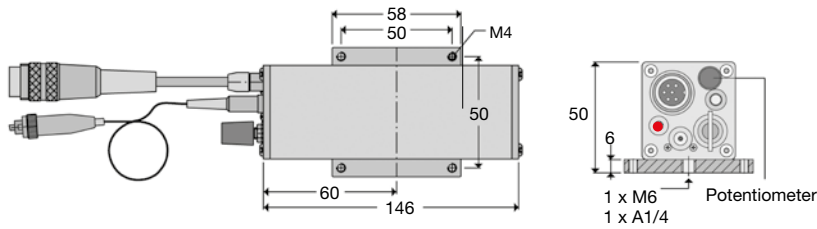
Length of fiber cable in cm (standard = 150)

Connector option:
 0 = standard
 C = core centered <0.25 µm (single-mode only)

Fiber type:
 10 = single-mode fiber cable, FC-PC connector (0°-polish)
 18 = single-mode fiber cable, FC-APC connector (8°-polish)
 20 = PM single-mode fiber cable, FC-PC connector (0°-polish)
 28 = PM single-mode fiber cable, FC-APC connector (8°-polish)
 Connector type AVIM (comp. with LSA), and E-2000 on request.
 Fiber connectors with end caps also available.

* Typical laser output power.
 ** Constant power: An internal control loop maintains constant laser power. Advantage: compensates for temperature variations or ageing of laser diode.
 Constant current: The internal control loop maintains constant laser current. The power output depends on temperature. Advantage: reduced laser noise.
 *** With effective fiber NAe² 0.07

Dimensions: Laser Diode Beam Source 58FCM

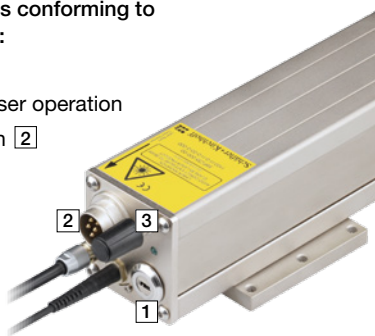


Electronics and Accessories for Laser Beam Sources Type 58FCM

Laser safety measures

Laser safety measures conforming to IEC 825 / EN 60825-1:

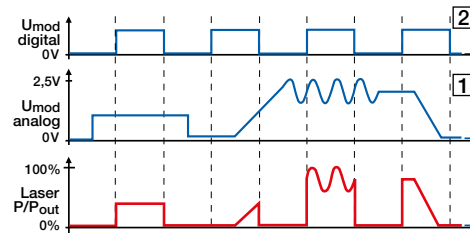
- Key switch [1]
- LED-indicator for laser operation
- Interlock connection [2]
- Potentiometer for reduction of power output [3]



Timing Diagram

Modulation: The laser has two AND-wired modulation input channels, U_{analog} [1] and U_{TTL} [2]. The laser is OFF when the modulation input is open. The laser can be modulated digitally. If only one modulation input is used then the other has to be set to +5V (see timing diagram).

The voltage U_{analog} at analog modulation input [1] linearly controls laser output power between $\leq 1\%$ and 100% of the optical power set by the potentiometer.



Electrical Data

Electronics Type		C	P
Supply voltage	standard	5V DC (± 0.2 V)	
	optional	12V DC (± 0.2 V)	
Laser diode operation mode		constant power	
	optional	constant current	
Max. operating current		250 mA	
Ambient temperature range		15–35°C	
Modulation frequency	analog	100 kHz	10 Hz
	TTL	100 kHz	250 kHz
Laser power output potentiometer		<1–100%	<5–100%
TTL modulation logic	Laser ON		TTL high
Analog control voltage	P_{min} to P_{max}		0–2.5 V

Connectors

Lumberg connector (female) according IEC 60130-9

Order Code BC 01 06 F

Type KV 60 (6-pin) for connection to interlock chain and for ext. modulation

Order Code BC 01 03 F

Type KV 30 (3-pin) for 5 V power supply

Order Code BC 01 04 F

Type KV 40 (4-pin) for 12 V power supply



Power Supplies for 58FCM...

Power supply for laser diode beam sources, electrically isolated, 1.5 m cable with connector (IEC60130-9) Lumberg series KV (female).

Connector (fem.) 5-pin KV50 for 5 V (pin comp. to SV30) or 4-pin KV40 for 12 V DC version



Input	100–240 V AC	
Output with connector	5 V DC/1 A BC0103F	12 V DC/0.5 ABC0104F
Order Code	PS051003E	PS120516E

Power cord for Power Supplies

1.5 m, IEC320 3-pin line socket, 10 A, 250 V AC with IEC-connector (IEC-60320)



Europe
Order Code
PC150 DE



USA/Canada
Order Code
PC150 US



Great Britain
Order Code
PC150 UK

Fiber Coupling Sets for HeNe Lasers

Single-mode and polarization-maintaining

Schäfter+Kirchhoff offer sets for fiber-coupling standard HeNe lasers to polarization-maintaining or single-mode fiber cables.

Based on the 60SMF Laser Beam Couplers, the sets provide a high coupling efficiency with extremely resilient transport capabilities. A large selection of coupling lenses is provided that match the different laser beam diameters with the particular PM fiber chosen for use. Both ends of the single-mode fibers have 8°-polish (connectors Type FC-APC) in order to minimize laser back-reflection and power noise effectively.

- Coupling efficiency >75%, typically 80%
- Polarization extinction ratio >23 dB
- Fiber cable MFD = 5.4 μm, NAe² = 0.075 (633nm)
- FC-APC type connector for coupler and fiber end (others available on request)
- Mounting brackets for strainless mounting, with shock absorbers to avoid vibration, shocks and thermal deformation: highly suitable for industrial environments
- Fiber-coupling solutions for HeNe lasers supplied by the customer
- Option: Mechanical shutter or attenuator locked by a grub screw, for release by a special tool to ensure laser safety
- Option: Electro-magnetic shutter for all HeNe laser types

For more information and technical drawings of the laser sources, please contact Schäfter+Kirchhoff.



Selection Criteria

How to choose the right components

1. Determine the collimated beam diameter of your laser
2. Choose the right 60SMF Laser beam Coupler from Table 1
3. Select the right single-mode or PM fiber cable from Table 2. Replace the "xxx" by the cable length you need in cm
4. Choose an adapter
5. Choose a mounting console
6. Consider the adjustment tools required

Table 1 60SMF Laser Beam Couplers for HeNe Laser

row		Wavelength [nm]	Coll. Beam Diameter (1/e ²) [mm]	Typ. Fiber NAe ² *	Best Coupling Focal length [mm]	Recommended Laser Beam Coupler
Red						
1	HeNe	633	0.44	0.071	3.1	60SMF-1-4-A3.1-02
2	HeNe	633	0.57	0.071	4.0	60SMF-1-4-A4-02
3	HeNe	633	0.64	0.071	4.5	60SMF-1-4-A4.5-02
4	HeNe	633	0.71	0.071	5.0	60SMF-1-4-M5-33
5	HeNe	633	0.88	0.071	6.2	60SMF-1-4-A6.2S-02
6	HeNe	633	1.07	0.071	7.5	60SMF-1-4-A7.5-02
7	HeNe	633	1.42	0.071	10	60SMF-1-4-M10-33
Green						
8	HeNe	543	0.70	0.070	5.0	60SMF-1-4-M5-33
9	HeNe	543	0.87	0.070	6.2	60SMF-1-4-A6.2S-01
Yellow						
10	HeNe	594	0.62	0.062	5.0	60SMF-1-4-M5-33
11	HeNe	594	0.76	0.062	6.2	60SMF-1-4-A6.2S-01

* Equivalent to a fiber with a nominal NA 0.12 - 0.13

Table 2 PMC or SMC Fiber Cables

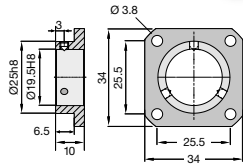
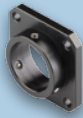
row		Color	Wavelength [nm]	Fiber Type	Typ. Fiber NAe ² *	Recommended Fiber Cable (length xxx in cm)
1	HeNe	Red	633	PMC	0.071	PMC-630-4.5-NA012-3-APC-xxx-P
2	HeNe	Red	633	SMC	0.083	SMC-630-4.0-NA013-3-APC-xxx
3	HeNe	Green	543	PMC	0.070	PMC-460-3.3-NA012-3-APC-xxx-P
4	HeNe	Green	543	SMC	0.076	SMC-460-3.5-NA013-3-APC-xxx
5	HeNe	Yellow	594	PMC	0.062	PMC-460-3.3-NA012-3-APC-xxx-P
6	HeNe	Yellow	594	SMC	0.071	SMC-460-3.5-NA013-3-APC-xxx

* Equivalent to a fiber with a nominal NA 0.12 - 0.13

Accessories: Adapters for standard HeNe Lasers

Adapter

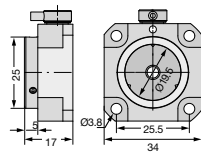
60A19.5-F is attached to the front plate of the laser.



Order Code
60A19.5-F

Adapter

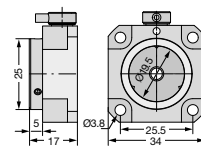
60A19.5-F-AT with integrated attenuator



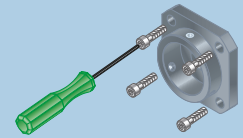
Order Code
60A19.5-F-AT

Adapter

60A19.5-F-S with integrated shutter



Order Code
60A19.5-F-S



Screw set for Adapter 60A19.5-F and HeNe laser
4 pcs. screws 4-40 x 3/8" (similar to DIN 912), washers and hex key 3/32
Set is supplied without adapter

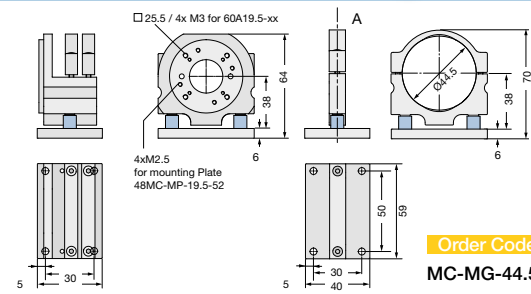
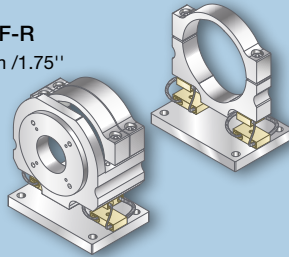
Order Code
60A19.5-F-MS

Accessories: Mounting Consoles for standard HeNe Lasers

Mounting Bracket MC-MG-44.5-F-R

for HeNe lasers with diameter 44.5 mm / 1.75" (set of two).

Flange mount of the 60SMF Laser Beam Coupler for an increased long-term stability.
Elastomer shock absorbers for dampening of shock, vibrations and avoidance of thermal deformations.

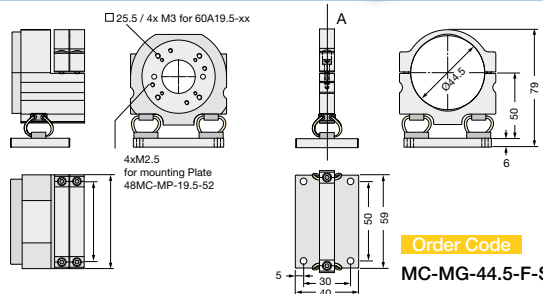
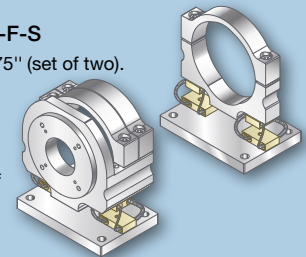


Order Code
MC-MG-44.5-F-R

Mounting Bracket MC-MG-44.5-F-S

for lasers with diameter 44.5 mm / 1.75" (set of two).

Flange mount of the 60SMF Laser Beam Coupler for an increased long-term stability Wire-spring shock absorbers for improved dampening of shock, vibrations and avoidance of thermal deformations in all xyz-directions.

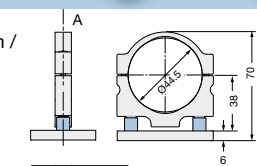
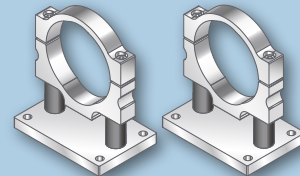


Order Code
MC-MG-44.5-F-S

Mounting Bracket MC-MG-44.5-R

for lasers with diameter 44.5 mm / 1.75" (set of two).

Elastomer shock absorbers for dampening of shock, vibrations and avoidance of thermal deformations.



Order Code
MC-MG-44.5-R

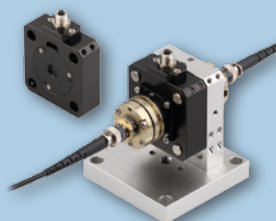
Related Products

Electro-magnetic Laser Shutter (multicube™ kompatibel)

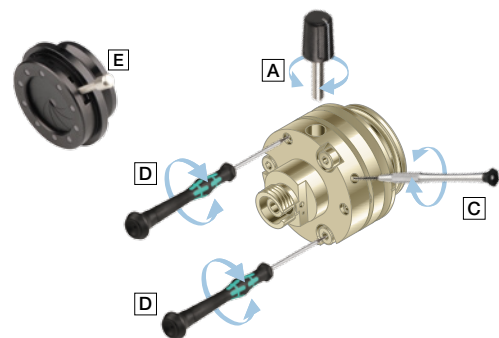
- 48EMS-0 (fiber-coupled) or 48EMS-6 (free beam)
- Shutter control unit SK97121C

This is not a laser safety shutter according to EN 60825. Additional laser safety measures may be necessary.

For more information, see page 87.



Adjustment tools



- | | | |
|---|-------------------|----------|
| A Eccentric key | Order Code | 60EX-4 |
| B as an alternative:
Eccentric key with long handle | | 60EX-4-L |
| C Screwdriver | Ø 1.2 mm | 9D-12 |
| D Hex screwdriver | SW Ø 1.5 mm | 50HD-15 |
| E Iris Aperture | Ø 1-13 mm | 13BL1-13 |



Fiber Coupling Sets with integrated Faraday Isolators

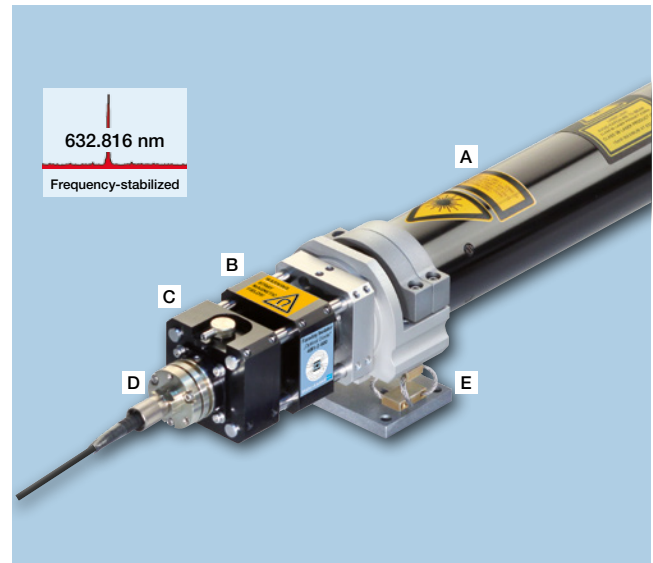
For Frequency-stabilized HeNe Laser

Schäfter+Kirchhoff offer a fiber-coupling set especially for frequency-stabilized HeNe lasers.

Additionally to the characteristics of the standard coupling sets this set includes a Faraday isolator and a mechanical shutter.

Components:

- Ⓐ Frequency-stabilized HeNe Laser e.g. from Research Electro-Optics, Inc.
- Ⓑ Faraday Isolator 48FI-2-633 to prevent unwanted back-reflections from entering the laser system.
- Ⓒ Mechanical shutter 48AT-S or attenuator for laser power output adjustment.
- Ⓓ Laser beam coupler 60SMF-1-4-A4.5S-02 transfers the beam into polarization- maintaining single-mode fiber PMC
- Ⓔ Mounting console type MC-MG-44.5-F-R or type MC-MG-44.5-F-S with spring shock-mounts for damping of shock and vibrations.



Additionally you need (not named in the photo):

- Mounting plate type 48MC-MP-19.5-S2
- Adjustable mounting plate type 48MB-19.5-SXY-1
- 4x multicube rods type 48MC-6-75

Associated Products

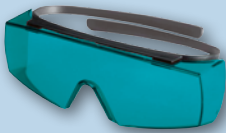
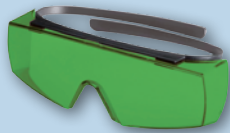
<p>Laser Beam Coupler system mount Ø 19.5 mm for a Ø 0.7 mm collimated beam</p> <p>Order Code 60SMF-1-4-A4.5S-02</p>	<p>Faraday Isolator Extinction > 40 dB Clear aperture Ø 2 mm multicube™ compatible</p> <p>Order Code 48FI-2-633</p>	<p>Rod for combining multicubes™</p> <p>Order Code 48MC-6-75</p>	<p>PM Fiber Cable Polarization-maintaining Fiber connectors of type FC/APC</p> <p>Order Code PMC-630-4.5-NA012-3-APC-xxx-P</p>
<p>Mounting Plate for attaching the multicube™ system to the mounting bracket MC-MG-44.5</p> <p>Order Code 48MC-MP-19.5-S2</p>	<p>Mechanical Shutter aperture Ø 3 mm, system mount Ø 19.5 mm multicube™ system</p> <p>Order Code 48AT-S</p>	<p>x/y Adjustment plate for lateral adjustment, translation 1 mm</p> <p>Order Code 48MB-19.5-SXY-1</p>	<p>Mounting Bracket MC-MG-44.5-F-R for HeNe lasers with diameter 44.5 mm /1.75" (set of two). Flange mount of the 60SMF Laser Beam Coupler Elastomer shock absorbers</p> <p>Order Code MC-MG-44.5-F-R</p>

Laser Safety

**Safety at Work:
Laser Safety and Laser
Safety Goggles**



Laser
Safety
Goggles



■ Laser Safety

Safety at Work —————→ 124

Laser Safety Goggles —————→ 125

Laser Classes EU Standard —————→ 126

Safety at Work: Laser Safety Goggles

Laser safety and laser adjustment goggles

- Laser safety goggles are recommended when working with lower power lasers from laser protection class 3R and beyond, such as all visible lasers from Schäfter+Kirchhoff with up to 5 mW of output power.
- Laser safety goggles are mandatory for protection class 3B and beyond, such as all invisible infrared lasers and all visible lasers from Schäfter+Kirchhoff with more than 5 mW of output power.
- The correct handling and use of laser safety goggles protects you and your colleagues against eye injuries from hazardous laser radiation.
- A selection of CE and GS certified laser safety goggles (manufactured by LaserVision, www.uvex-laservision.de) are provided for the lasers manufactured by Schäfter+Kirchhoff.
- The type of frame is dependent upon whether glass or plastic filters are fitted. Laser safety goggles with glass filters (Order Code RX7) have a heavier frame with a facility for attaching personal spectacles, according to individual requirements. Laser safety goggles with plastic filters are lighter and can be worn over normal spectacles.
- The two distinct protective functions of either full protection goggles or alignment protection goggles need emphasizing (see box below).



Accessories – Insert for Spectacles



As an accessory for the laser protection goggles of type R01.T1A01 and R01.T1Q01, the insert RX7 for personal spectacles is available.

Order Code **RX7**

Laser Safety Goggles – Function and Characteristics

Protective function. Full protection goggles and alignment goggles provide different levels of safety and laser protection.

Full protection goggles, conforming to European standard EN 207, provide personal protection against laser radiation. The laser radiation is blocked and is no longer visible.

The **protection levels** (such as protection level LB..) differ in the maximum spectral transmission of the filter glasses. The EN 207 standard specifies a maximum incident laser power density (power per unit area, in W/m²) for the laser power that is allowed to irradiate the filter glass.

Alignment protection goggles, conforming to European standard EN 208, reduce the visible laser radiation (400–700 nm wavelengths) to that of the power of laser class 2 (EN 60825-1). The laser radiation remains visible, to allow alignment protection glasses to be used for adjustment tasks, while offering significant laser protection safety.

The **protection levels** (protection level RB..) describe the maximum power (watts) of a collimated laser beam that is allowed to irradiate the goggles.

Maximum power (EN 208): the maximum power of a laser beam in a specified wavelength range that is sufficiently attenuated by the alignment protection goggles (in accordance with EN 208).

Maximum transmission (EN 207): maximum transmission (minimum attenuation) in a specified wavelength range (according to EN 208).

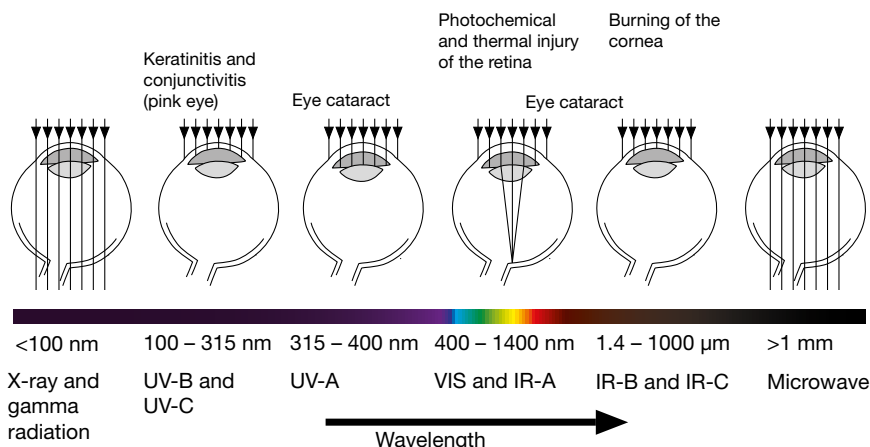
Maximum power density (EN 207): maximum power density that the filter glasses can withstand over a longer period (according to EN 207).

VLT (visible light transmission): in addition to the specified wavelengths, laser protection goggles also attenuate ambient light. The VLT is expressed as the percent transmitted daylight.

OD (optical density): logarithmic scale for the attenuation of radiation at a specified wavelength. The OD at wavelength λ is defined as:

$$OD(\lambda) = -\log_{10} \tau(\lambda)$$

Type of Eye Damage caused by Radiation

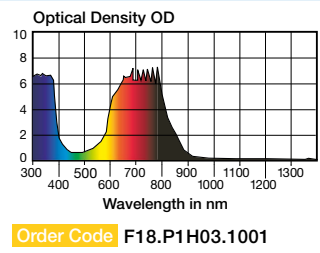


Laser Safety Goggles

**Full Protection Goggles
DIN EN 207**



VLT = 10%

Usable Range

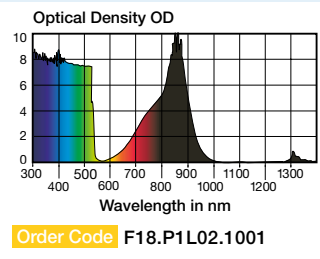
Pro-tection	Wavelength [nm]	Pro-tection Level	max. Trans-mission (EN 207)	max. Power Density (EN 207)	max. Power (EN 208)
Full	610 - 630	LB5	10 ⁻⁵	10 ⁶ W/m ²	-
Full	630 - 660	LB6	10 ⁻⁶	10 ⁷ W/m ²	-
Full	660 - 775	LB6	10 ⁻⁶	10 ⁷ W/m ²	-
Full	775 - 790	LB6	10 ⁻⁶	10 ⁷ W/m ²	-

Full protection goggles for cw lasers in the 600 - 800 nm wavelength range

**Full Protection Goggles
DIN EN 207**



VLT = 30%

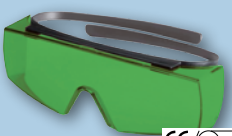



Usable Range


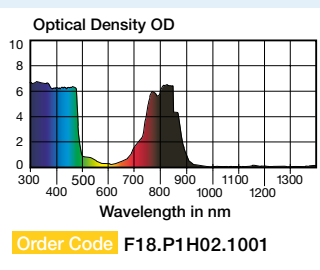
Pro-tection	Wavelength [nm]	Pro-tection Level	max. Trans-mission (EN 207)	max. Power Density (EN 207)	max. Power (EN 208)
Full	315 - 532	LB6	10 ⁻⁶	10 ⁷ W/m ²	-

Full protection goggles for cw lasers in the 315 - 532 nm wavelength range

**Full and Alignment
Protection Goggles
DIN EN 207 / DIN EN 207**



VLT = 42%

Usable Range

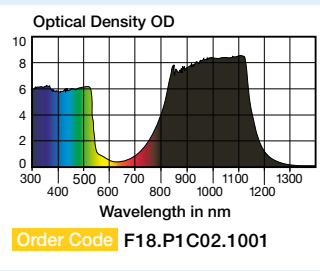
Pro-tection	Wavelength [nm]	Pro-tection Level	max. Trans-mission (EN 207)	max. Power Density (EN 207)	max. Power (EN 208)
Alignment	660 - 675	RB2	-	-	100 mW
Full	700 - 755	LB5	10 ⁻⁵	10 ⁶ W/m ²	-
Full	755 - 810	LB6	10 ⁻⁶	10 ⁷ W/m ²	-
Full	810 - 820	LB5	10 ⁻⁵	10 ⁶ W/m ²	-

Alignment protection goggles are for lasers in the 660 - 675 nm wavelength range
Full protection goggles for the 700 - 820 nm wavelength range

**Full Protection Goggles
DIN EN 207**



VLT = 60%

Usable Range

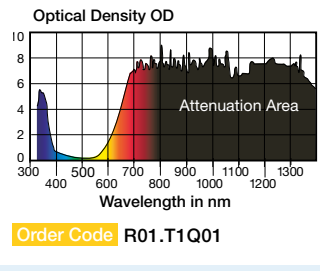
Pro-tection	Wavelength [nm]	Pro-tection Level	max. Trans-mission (EN 207)	max. Power Density (EN 207)	max. Power (EN 208)
Full	780 - 810	LB3	10 ⁻³	10 ⁴ W/m ²	-
Full	810 - 860	LB4	10 ⁻⁴	10 ⁵ W/m ²	-
Full	860 - 900	LB5	10 ⁻⁵	10 ⁶ W/m ²	-
Full	800 - 1080	LB6	10 ⁻⁶	10 ⁷ W/m ²	-
Full	1080 - 1100	LB4	10 ⁻⁴	10 ⁵ W/m ²	-

Full protection goggles for lasers in the 780 - 1100 nm wavelength range

**Full Protection Goggles
DIN EN 207 / DIN EN 208**



VLT = 15%

Usable Range

Pro-tection	Wavelength [nm]	Pro-tection Level	max. Trans-mission (EN 207)	max. Power Density (EN 207)	max. Power (EN 208)
Full	690 - 1320	LB7	10 ⁻⁷	10 ⁸ W/m ²	-
Full	1320 - 1550	LB3	10 ⁻³	10 ⁴ W/m ²	-

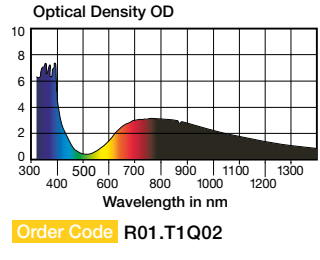
All-round goggles as full protection for cw lasers in the 690 - 1500 nm wavelength range

Laser Alignment Goggles

**Full and Alignment
Protection Goggles
DIN EN 207 / DIN EN 208**



VLT = 25%

Usable Range

Pro-tection	Wavelength [nm]	Pro-tection Level	max. Trans-mission (EN 207)	max. Power Density (EN 207)	max. Power (EN 208)
Alignment	630 - 635	RB3	-	-	1000 mW
Full	630 - 680	LB2	10 ⁻²	10 ³ W/m ²	-

Alignment/full protection goggles for cw lasers in the 630 - 690 nm wavelength range

Please Note: Typical density curves for the respective filters are shown for information only and are not guaranteed values. Only the protection levels (RB.. or LB..) are guaranteed by Schäfter+Kirchhoff.

Laser Safety

To be in accordance with DIN IEC 60825-1:2007, every laser system must be labeled with a warning triangle. Additionally, all lasers must be labelled with additional warning information specific to the laser class:

- Class 1:**
" CLASS 1 LASER PRODUCT "
- Class 1M:**
" LASER RADIATION, DO NOT VIEW DIRECTLY WITH OPTICAL INSTRUMENTS, CLASS 1M LASER PRODUCT "
- Class 2:**
" LASER RADIATION, DO NOT STARE INTO BEAM, CLASS 2 LASER PRODUCT "
- Class 2M:**
" LASER RADIATION, DO NOT STARE INTO BEAM OR VIEW DIRECTLY WITH OPTICAL INSTRUMENTS, CLASS 2M LASER PRODUCT "
- Class 3R:**
" LASER RADIATION, AVOID DIRECT EYE EXPOSURE, CLASS 3R LASER PRODUCT "
- Class 3B:**
" LASER RADIATION, AVOID EXPOSURE TO THE BEAM, CLASS 3B LASER PRODUCT "
- Class 4:**
" LASER RADIATION, AVOID EYE OR SKIN EXPOSURE TO DIRECT OR SCATTERED RADIATION, CLASS 4 LASER PRODUCT "

Furthermore, all lasers of class 2 to 4 must exhibit a warning that lists the laser specifications, including the laser source, the wavelength and the laser power or pulse energy.

If the laser is enclosed but the housing can be opened then the housing must also be labeled with a warning triangle and the requisite information about the laser class, as listed below:

- Class 1:** The laser is safe for any form of measurement task and the maximum permitted exposure (MPE) cannot be exceeded. Enclosed high power laser systems, with an integrated automatic shutdown system on opening of the enclosure, are also included in this laser class.
- Class 1M:** As for class 1, except when magnifying optics such as microscopes and telescopes are used: safety limits may be exceeded and class 3 dangers may be possible.
- Class 2:** Visible laser light (400–700 nm) with <1 mW continuous wave (CW) and/or <0.25 s exposure time (with an energy limit according to the standard) is considered to be safe. Radiation either side of the 400–700 nm range is considered to be class 1.
- Class 2M:** As for class 2, except when magnifying optics such as microscopes and telescopes are used.
- Class 3R:** If handled carefully, the laser is considered safe because only a low risk of injury exists. Visible CW lasers in Class 3R are limited to 5 mW. For other wavelengths and for pulsed lasers, other limits apply.
- Class 3B:** Direct exposure is hazardous for the eye, but diffuse reflections such as from paper are not harmful. The limits apply to wavelengths and to operation mode (as for CW and pulsed lasers). Laser safety goggles are absolutely required when a direct view of the laser beam is at all possible. Class 3B lasers must be equipped with an isolating key switch and a safety interlock.
- Class 4:** Every type of laser beyond class 3B.

Further Product Catalogues:



<https://www.sukhamburg.com/support/catalogue.html>

Contact details:

Schäfter + Kirchhoff GmbH
Kieler Str. 212
22525 Hamburg
Germany

Tel: +49 40 85 39 97-0
Fax: +49 40 85 39 97-79

info@sukhamburg.de
www.sukhamburg.com