

# LINE SCAN CAMERAS

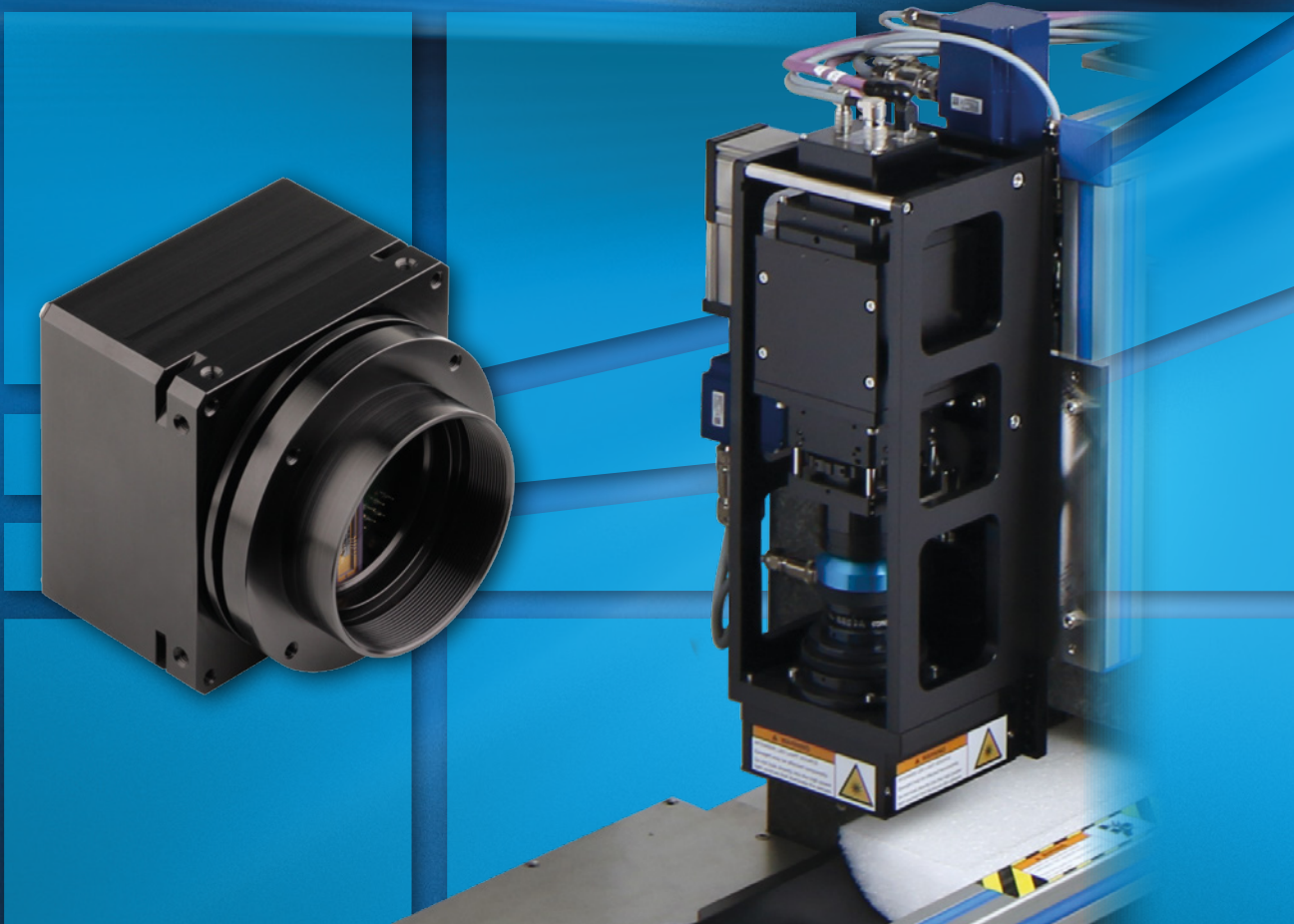

Line Scan Cameras · Modular Scanner Systems · Specialized Scanner Systems

## ■ Quality and Reliability

---

Schäfter+Kirchhoff GmbH is based in Hamburg, Germany. From here we manufacture high quality optical products that are delivered to customers all around the world.

The company was founded over 60 years ago, and began with classical lens design and customized optical solutions. The focus has shifted gradually towards the current three product lines: polarization-maintaining fiber optics, laser lines and line scan cameras.

A major focus is our winning combination of high optical and mechanical precision, which is the basis for the high quality, stability and durability of our products. We are committed to providing the highest quality and reliability possible, a goal continuously improving because of our quality control system. Schäfter+Kirchhoff GmbH is certified according to the ISO 9001 standard.

Our extensive know-how and our highly qualified and strongly committed employees are the driving force behind the company. To have sales, research and development, as well as manufacturing, so closely knit together ensures a quick and efficient response to customer needs.

After 60 years of private ownership, Schäfter+Kirchhoff GmbH was transferred in 2016 to the Gregor Federau Foundation, which was established by the former owner of the company to support child and youth welfare.

com

# Line Scan Cameras and Modular Scanner Systems



## Schäfter+Kirchhoff

OPTICS

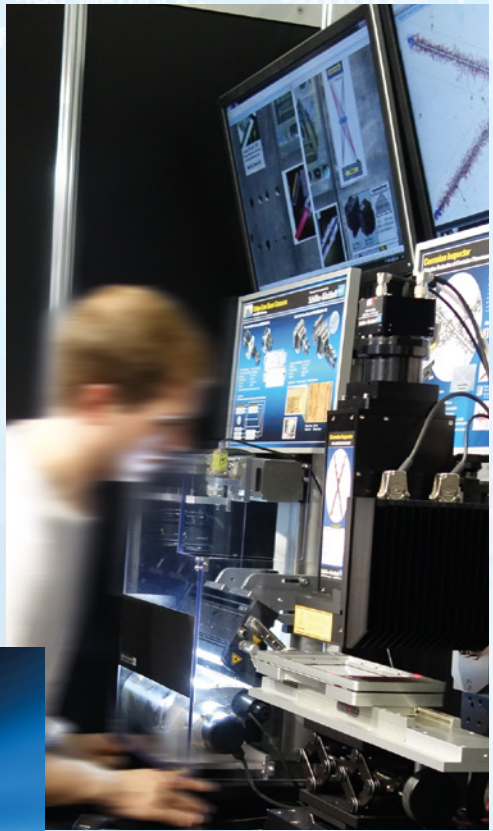

# Contents

## Introduction to Line Scan Cameras

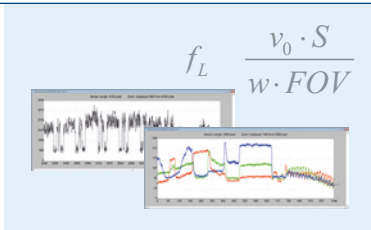

<b>Fundamentals: Function and Applications</b>	<b>8</b>
What are Line Scan Cameras?	8
Setting up a Line Scan Camera System	12
Choosing the Appropriate Camera Interface	14
How to Order: Using the Product Configurator	16

## Line Scan Cameras



<b>Gigabit Ethernet, GigE Vision™ Cameras</b>	<b>20</b>
Overview: Camera Types	21
Overview: System Setup and Accessories	22
Accessories: Software	23
Accessories: Connection Cables and Power Supply	23
Camera Types: Monochrome	24
Camera Types: Monochrome, CMOS, for spectrophotometry	26
Camera Types: Color	27



<b>USB3.0 Cameras</b>	<b>30</b>
Overview: Camera Types	31
Overview: System Setup and Accessories	32
Accessories: Software	32
Accessories: Connection Cables and Power Supply	33
Camera Types: Monochrome	34
Camera Types: Monochrome, CMOS, for spectrophotometry	36
Camera Types: Color	37



<b>Camera Link Cameras</b>	<b>40</b>
Overview: System Setup and Accessories	40
Overview: Camera Types	41
Accessories: Connection Cables and Power Supply	41
Camera Types: Monochrome	42
Camera Types: Color	44



<b>Casings and Dimensions</b>	<b>46</b>
Gigabit Ethernet / GigE Vision™ Interface	48
USB3.0 Interface	50
Camera Link Interface	52

## Software

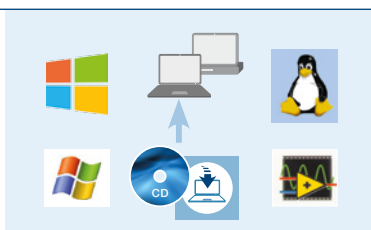

<b>Software for Line Scan Cameras</b>	<b>56</b>
SkLineScan Program	57
Software Development Kit (SDK)	59
Overview: Software Products	59

## Accessories

### Accessories for Standard Cameras (Sensor Length up to 41 mm) 60

- Overview 60
- Components 61



### Accessories for Large Format Cameras (Sensor Length up to 71 mm) 64

- Overview 64
- Components 65



### Lenses 66

- Fundamentals: Choosing an Appropriate Camera Lens 66
- Scan Lenses C-Mount 70
- Photo and Enlarging Lenses 71
- Scan Lenses 72
- Macro Lenses 74



## Modular Scanner Systems

### Scanner Systems for Industry and Laboratory 78



- Linear Scanner System for Measurement Tasks 80
- Product Info: Corrosion Inspector 81
- High End Imaging and Illumination Optics 84
- Product Info: LASM for Ice Core Inspection 85
- Color Scanner - Linear 87
- Color Scanner - Rotation 88
- Scanner Systems – Robot-Guided 89



# Introduction

**Introduction:  
How to choose the right  
Line Scan Camera and  
set it up**

## ■ Introduction to Line Scan Cameras

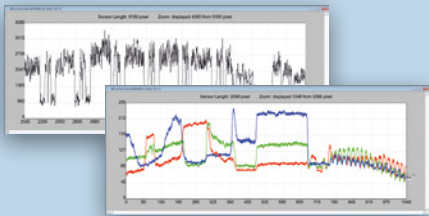

Fundamentals:	
Function and Applications	8
What are Line Scan Cameras?	8
Setting up a Line Scan Camera System	12
Choosing the Appropriate Camera Interface	14
How to Order:	
Using the Product Configurator	16

# What are Line Scan Cameras?



## Technotes and Fundamentals

For more information, please refer to the extensive technotes section on: [www.sukhamburg.com/support/technotes.html](http://www.sukhamburg.com/support/technotes.html)



Line scan cameras are semiconductor cameras used in many industrial environments. The single photosensitive line sensor contains – depending on type – up to 22800 picture elements (pixels). Light energy incident on the sensor is transformed into an electric signal for digitization within the camera.

At 8-bit resolution, the A/D converter transmits the output voltage of each pixel into one of 256 brightness levels, at 12-bit resolution into 4096 brightness levels.

Color line scan cameras provide three separate line signals for Red, Green and Blue with either 3 x 8-bit or 3 x 12-bit per pixel. The digitized output signal is transferred to a computer via various interfaces according to requirements, e.g. Gigabit Ethernet or USB 3.0.

## The advantages of a line scan camera include

- high optical resolution of up to 8160 pixels (monochrome) or 3 x 7600 pixels (color RGB)
- high speed of up to 54 kHz line frequency
- flexible parameter setting for the line scans
- synchronizing of each individual line, as well as the triggering of frames
- when focused on the zenith of cylindrical objects, the line scan camera delivers sharp, distortion-free images of the external surface during rotation
- flexible image height from 1 up to 64000 lines per image
- continuous scanning of endless materials such as foils or paper without a time limit.

## Creating an image

The image produced by a line scan camera is one-dimensional and represents the brightness profile of an object, captured at the current position of the line sensor. A two-dimensional image is generated by performing a scanning movement of either the object or the camera, during which the individual line signals are transferred to the computer and assembled one by one into a 2D image.

## Improving the image

High image quality can only be achieved with the appropriate combination of line scan camera, high resolution lens, appropriate lighting and a precise motor unit, whether rotary or linear drive or a conveyor belt. For an image to be correct in all proportions, the scanning speed and the image acquisition process must be highly synchronized and this is most easily achieved by adjusting the transport speed to the line frequency of the camera. However, in practice, it is usually the transport speed and the image resolution that are constraining and these predefine the line frequency and ultimate choice of line camera.

At constant transport speeds, such as when examining objects on a conveyor belt, a line scan camera can be allowed to operate in a free-running mode. Where there are velocity fluctuations or discordant movements then external triggering of the line scan camera is required. The trigger pulses, e.g. from an encoder, are equidistant and independent of the movement velocity so that the camera will be triggered after a constant travelled distance.

This precise synchronization guarantees images with a reproducible resolution and correct aspect ratio.

The line frequency  $f_L$  can be calculated for a given object speed  $v_o$  and field width  $FOV$ , sensor length  $S$  and pixel width  $w$  from

$$f_L = \frac{v_o \cdot S}{w \cdot FOV} \quad (1)$$

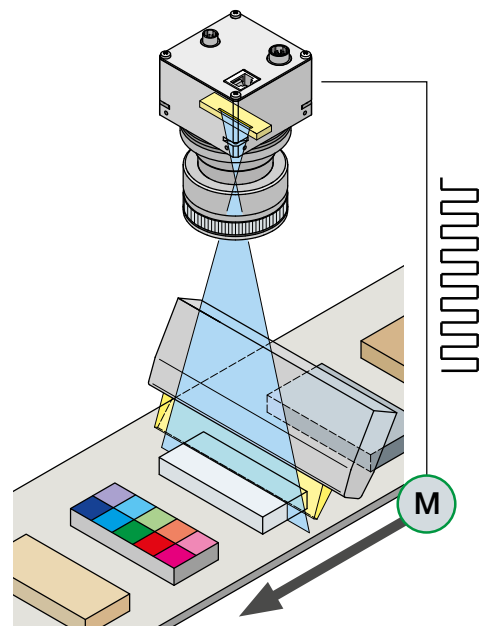

The production of a 2D image requires precise synchronization of the line camera sensor and the speed of transport of the object.



# Line Scan Camera Applications

Generally, the applications can be grouped into one-dimensional or two-dimensional measuring tasks.

For one-dimensional applications, the measured result is extracted from the pixel information of an individual line scan. Measurements of two-dimensional images require moving either the object or the line sensor.

## Camera Application:

### 1-dimensional

- Signal generation: individual line scan
- Examples: measurement of width, rod diameter, edge positions, glass thickness.

### 2-dimensional

- Several line scans are combined to produce a 2D image (frame)
- Examples: surface inspection, endless webbing inspection, texture analysis, scanning.

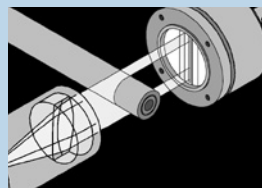

**Laser shadow boundaries**  
Determination of rod diameters, by evaluation of shadow boundaries excited by the laser beam

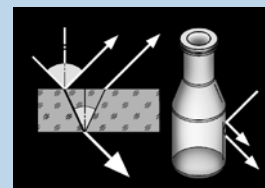

**Glass thickness measurement**  
Partial reflections at surfaces reach the line scan sensor with distinct timing off-sets that are related to glass thickness.

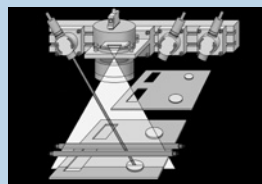

**Conveyor belt**  
A line scan camera can provide height information during object transit using laser triangulation

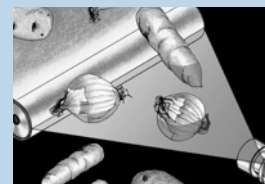

**Screening installation**  
Objects are sorted according to size or for defects as they drop through a line scan camera field

## Optical Resolution

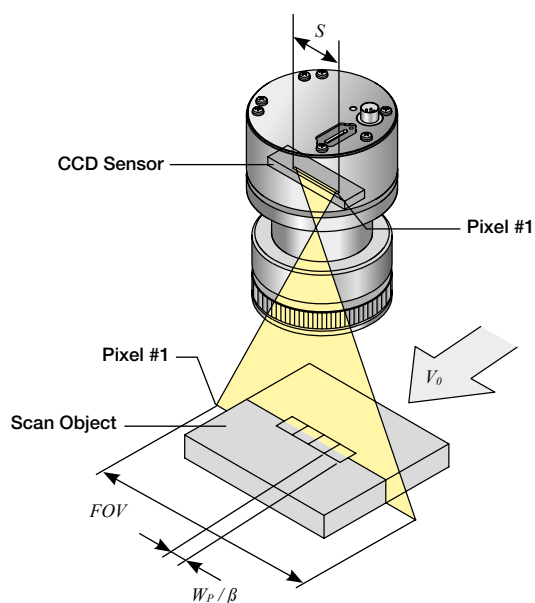

The native resolution of an optical line scan camera is defined by the number of pixels – the row of photosensitive elements in the sensor line. Line scan cameras are available with more than 8000 pixels.

The resolution of the scanner system is determined by the objective lens chosen and the scale of the image  $\beta'$ , as a function of the ratio of image size ( $FOV$ , field of view) to object size  $S$ :

$$\beta' = \frac{S}{FOV} \quad (2)$$

$$p' = \frac{w}{\beta'} \quad (3)$$

Also, to maintain the correct aspect ratio for an image, the pixel resolution  $p'$ , (3) in the direction of the sensor X-axis must be identical to that in the direction of the transport Y-axis, perpendicular to the sensor. The resolution in the direction of transport is a function of transport speed and the line frequency of the camera as determined in Equation (1).

An identical resolution in both the X and Y-axis directions is an absolute prerequisite for the accurate geometrical measurement of the surface characteristics of the test object. The optical resolution of the scanner system is often reported in dots per unit length, usually dots per inch or dpi.

### Comparison: a conventional area camera and various line scan cameras

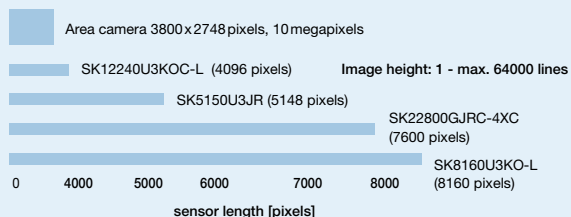

## Synchronization of line scan cameras

In practice, a line scan camera has to be externally synchronized in order to obtain distortion-free images, e.g. triggered by an encoder.

**There are two different synchronization functions that can be applied together or individually:**

1. **Line synchronization:**  
A TTL signal at the LINE SYNC input triggers each individual exposure of the sensor line by line.
2. **Frame synchronization:**  
The recording of a set of lines (frame) representing a two-dimensional image is triggered by a TTL signal at the FRAME SYNC input.

### Line Synchronization Modes:

#### FreeRun / SK Mode 0

The acquisition of each line is synchronized internally (free-running) and the next scan is started automatically after completion of the previous line scan. The line frequency is determined by the programmed value.

#### LineStart / SK Mode 1

After an external trigger pulse, the currently exposed line is read out at the next internal line clock. The start and duration of the exposure are controlled internally by the camera and are not affected by the trigger pulse. The exposure time is programmable. The line frequency is determined by the frequency of the trigger signal.

Limitations: The period of the trigger signal must be longer than the exposure time used. Between the external trigger signal and the internally generated line clock, jitter occurs in the range of the exposure time.

#### ExposureStart / SK Mode 4

(only available when the camera supports integration control)

A new exposure is started exactly at the point in time of the external trigger pulse. The exposure time is determined by the programmed value. The exposed line is read out after the exposure time has elapsed. The frequency of the trigger signal determines the line frequency.

Limitation: The period duration of the trigger signal must be longer than the exposure time used.

#### ExposureActive / SK extSOS (Mode 5)

The exposure time and the line frequency are controlled by the external trigger signal. This affects both the start of a new exposure (Start of Scan-Pulse, SOS) and the readout of the previously exposed line.

### Frame Synchronization

The camera suppresses the data transfer until a falling edge of a TTL signal occurs at the FRAME SYNC input. This starts the acquisition of a 2D area scan. The number of image lines must be programmed in advance. Any of the available line synchronization modes can be used for the individual line scans.

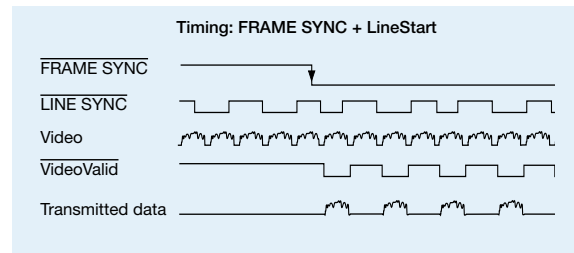

### Shading correction and white balance

All lenses show some vignetting as a function of the field angle. Hence, even with homogeneous object illumination, the signal intensity of the image decreases with increasing image height.

Shading correction (or flat field compensation) is used to compensate for lens vignetting **A** as well as for inhomogeneity in the illumination. Shading correction is achieved by performing a white balance calibration during illumination of a homogeneous white target.

An individual gain for each pixel is obtained by scaling each value to a normalized maximum signal. The oscilloscope display now shows a homogeneous intensity distribution along the entire length of the line sensor **B**.

The shading correction procedure is also used for white balance calibrations in color line scan cameras. The different sensitivities of the individual color channels of the sensor are compensated for, as well as any color inhomogeneity arising from the illumination source.

The SkLineScan software package provides all necessary functions for the performance of shading correction and white balance.

For individual software needs, library functions for shading correction and white balance are provided in the SDKs for the various interfaces.

#### Shading correction and white balance

- A** A monochrome line scan camera signal of a homogeneous white calibration target showing signal trimming caused by either lens vignetting or inhomogeneous object illumination
- B** Monochrome line scan camera signal after shading correction
- C** Signal from a color line scan camera of a homogeneous white calibration target showing the effect of trimming on red, green and blue signals
- D** Color line scan signal after shading correction
- E** Pop-up window for performing shading correction in the SkLineScan software allows white balance calibration to be performed automatically or manually

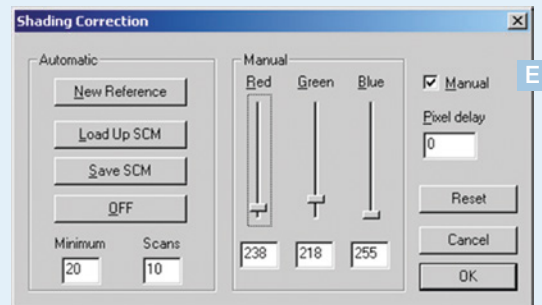
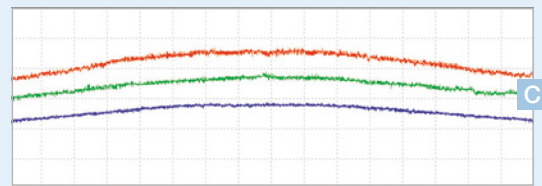
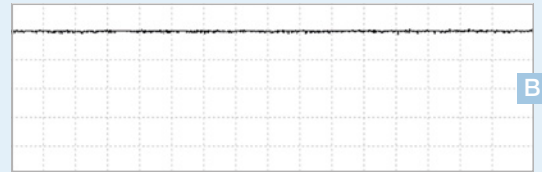
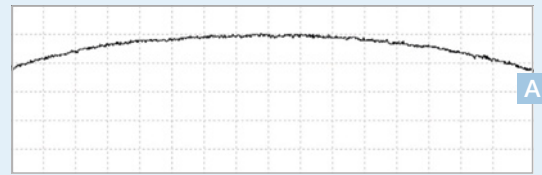

### Sensor alignment

For linear illumination sources, rotating the line sensor results in asymmetric vignetting.

The camera and illumination optics can be aligned optimally by monitoring the object illumination using the oscilloscope display.

**A** Sensor and illumination optics rotated in apposition

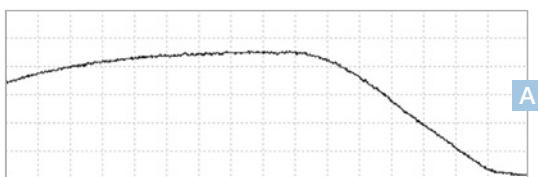

**B** Sensor and illumination optics aligned properly

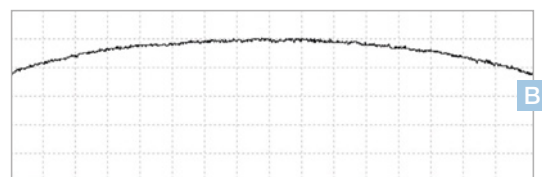

# Setting up a Line Scan Camera System

## Lens focusing performed using the oscilloscope display

The real-time display of the line scan camera signal facilitates the focusing of the camera lens. This display can even be used to focus a line scan camera system when making measurements in two dimensions.

Variations in edge steepness at dark-bright transitions and modulations in the line scan signals provide a useful mechanism for establishing the correct focus (see figure). Initial focusing is performed with a fully opened aperture, when the depth of field is at its smallest and the sensitivity of focus adjustment is at its largest. The integration time can also be shortened to provide a sufficiently sensitive low amplitude signal.

## Evaluation of a correct focus setting by using the line scan signal

**A** Line scan camera out of focus:  
edges are indistinct, signal peaks are blurred with low modulation of high frequency densities

**B** Zoom of highlighted area in **A**

**C** Area scan with focus settings **A** and **B**

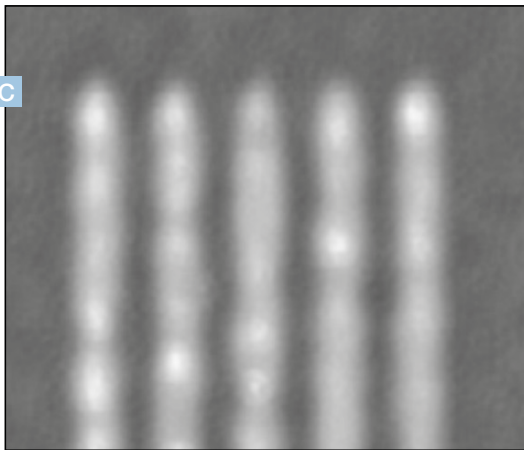
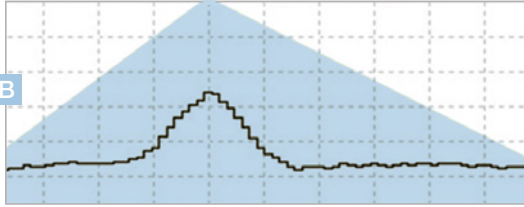
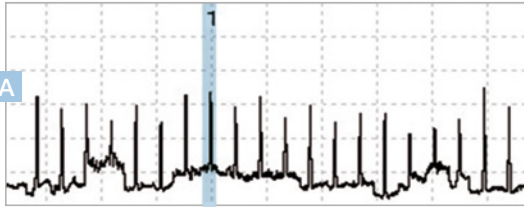

**D** Line scan camera signal with optimal focus setting:  
dark-bright transitions have sharp edges, highly modulated signal peaks with high frequency density variations

**E** Zoom of highlighted area in **D**

**F** Area scan with focus settings **D** and **E**

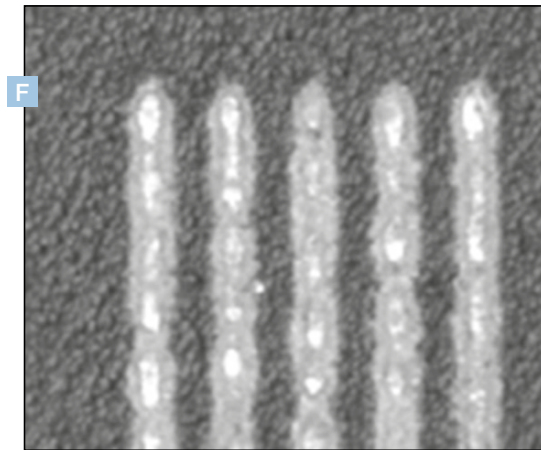
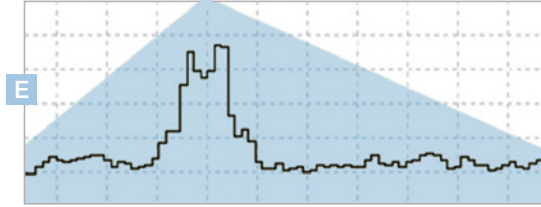
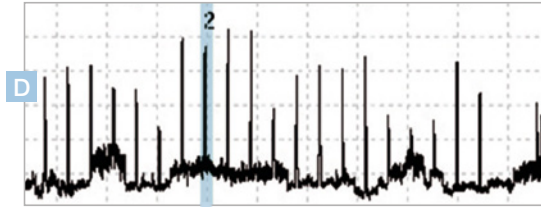

# Blooming – Anti-Blooming Fundamentals

## Blooming and Anti-Blooming Correction

When the line sensor is saturated from excessive illumination and cannot accumulate more charges, the overloaded pixels transfer some of the excess charge to adjacent pixels – an effect termed blooming. Blooming leads to the corruption of the geometrical assignment of both the signal and the image generated by the line sensor.

A line scan camera with an anti-blooming sensor can effectively dissipate the surplus charge arising from over-exposure by using a 'drain gate'. The less exposed neighboring pixels are no longer corrupted. Over-exposures of up to 30-fold can be drained successfully, depending on the pixel frequency and spectral range of the line sensor.

Line scan camera signal from a bar code using a midtone incident light and the SK2048U3JR line scan camera without an anti-blooming sensor.

- 1 Line signal with enhanced illumination of the central range

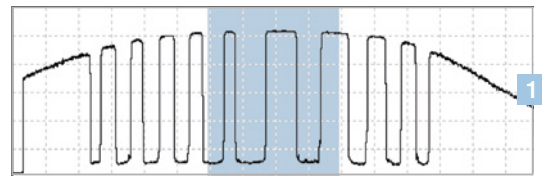

- 2 Zoom of the signal depicted in 1 showing the steep signal edge

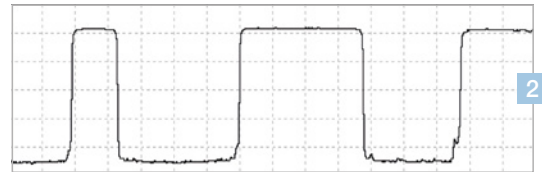

- 3 Extension of the integration time by a factor of 3.81 produces edges that are no longer vertical and have noticeable shoulders – the blooming of the sensor has begun

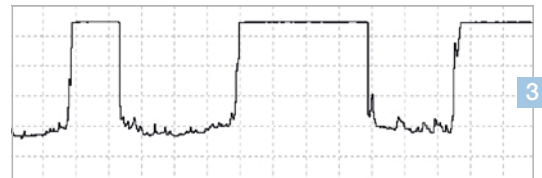

- 4 Over-exposure caused by too large an integration time leads to severe signal and data corruption when using line scan cameras without anti-blooming

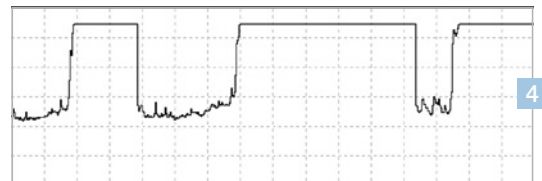

- 5 Extreme over-exposure floods the dark pixels of the sensor, the offset control is disturbed and the line scan camera produces an attenuated signal

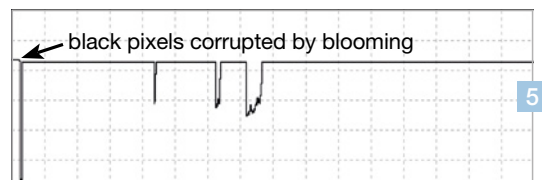

# Choosing the Appropriate Camera Interface

Schäfter+Kirchhoff supplies more than 70 different types of line scan camera with either a Gigabit Ethernet, GigE Vision, USB3.0 or CameraLink interface. The choice of interface should be considered at an early stage of a new line scan camera project, because this determines important properties such as maximum cable length and maximum line frequency. The table below provides a detailed comparison of the available camera interfaces.



- Advanced preprocessing (shading correction, thresholding)
- Customer-specific I/O signals
- Large distances between camera and PC possible



- GigE Vision™ and Gen<i>>CAM™ standards ensure third party hard and software compatibility
- Large distances between camera and PC possible



- High performance line scan cameras, suitable for mobile measurement systems
- Does not require an external power supply for power consumptions up to 4.5W



- Industry-common standard for machine vision
- Very high transfer speeds
- Requires separate CameraLink grabber

## Properties

Max Cable Length		100 m	100 m	3 m up to 100 m with fiber optical cable extension	10 m
Max Pixel Frequency		120 MHz	120 MHz	150 MHz	3 x 70 MHz
External Synchronization	Line Sync				
	Frame Sync				
	Sync Divider				—
Number of Devices		up to 255	up to 255	up to 127	up to 4
Grabber Board		—	—	—	CameraLink Frame Grabber
Required PC interface		GigE	GigE	USB 3.0	
External Power Supply		required	required	not required	required

## Available Software

Image Aquisition and Configuration Tools	Windows	SkLineScan-GigE-WIN SkGigEconfig tool	SkLineScan-GigE-WIN 3rd party	SkLineScan-U3-WIN	SKCLconfig tool
	LabView		NI-IMAQdx		Grabber dependent
	Linux			SkLineScan-U3-LX	
Software Development Kit (SDK)	Windows	SK91GigE-WIN		SK91USB3-WIN	Grabber dependent
	LabView	-	3rd party: e.g. CVB, Halcon, NI-IMAQdx	SK91USB3-LV	
	Linux		Pleora SDK	SK91USB3-LX	

## Software Compatibility

Gen<i>>CAM™	—		—	Grabber dependent
-------------	---	--	---	-------------------

# Features Selection Criteria

In addition to the interface, other important technical features of the cameras should be considered when selecting a camera for the required application.

Technical considerations include:

- pixel number
- pixel size
- sensor length
- maximum line rate
- anti-blooming
- integration control
- dynamic range
- spectral sensitivity

## Pixel number / line rate:

A high optical resolution is obtained from a large number of pixels. However, the line rate of the chosen camera must be high enough to reach this resolution in the scanning direction at a given scanning speed.

## Sensor length:

A suitable lens must be available for the specified sensor length and desired magnification.

## Anti-blooming:

Blooming from the transfer of excess charges from oversaturated pixels to adjacent pixels can cause signal broadening and signal loss. Cameras with an anti-blooming function drain the excess charge and restore favorable signal characteristics.

## Integration control:

Line scan frequency is inversely proportional to exposure time; while the charges from a finished line scan are read out, the next line scan is being exposed. Thus, the minimum exposure period is achieved at the maximum line scan frequency. Integration control can act as a shutter by truncating the accumulation of charges and ending the line scan period. For high light intensities, over-exposure and blooming can also be avoided using integration control.

## Dynamic range and digitalization depth:

Depending on the sensor used, line scan cameras are characterized by their dynamic range (signal-to-noise ratio). Some digital line scan cameras can be operated with either 8 or 12-bit digitalization depths.

## Spectral sensitivity:

The spectral sensitivity of the line scan camera must be appropriate to the wavelengths of the light source used and the optical properties of the measured object.

Cameras used for laser-based measurement systems have different spectral sensitivities than a color scanning system.

Because of these spectral sensitivity characteristics, a color line scan camera of the KOC series requires a UV/IR blocking filter when used in daylight.



Quick and efficient product selection with the Product Configurator: [www.sukhamburg.com](http://www.sukhamburg.com)

## Relative spectral sensitivity of various line scan cameras

Camera series ..SD, ..TO with typical spectral sensitivity of silicon

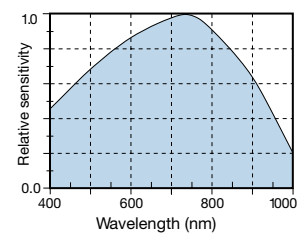

Camera series ..JR with increased blue-green sensitivity

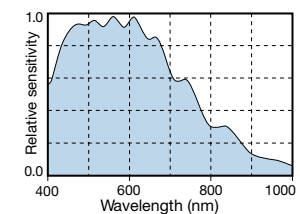

Camera series ..HA, ..HU, ..HV, ..HW CMOS sensors with enhanced spectral sensitivity and with rectangular pixels, especially suitable for spectroscopic applications

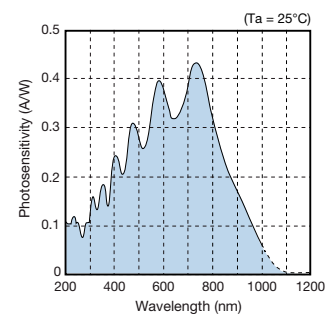

## Color series cameras ..KOC

for a color sensor with RGB sensitivity, the spectral detection can be confined to only the visible range of 400 –700 nm by using a UV/IR blocking filter

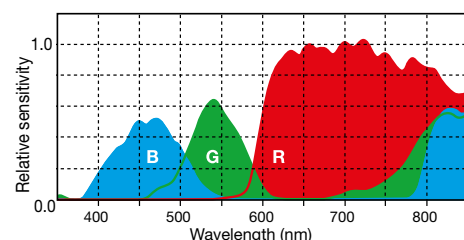

# How to Order Using the Product Configurator

## Using the Product Configurator



### Fast and easy selection of line scan cameras on [www.sukhamburg.com](http://www.sukhamburg.com)

The new product configurator for line scan cameras, helps select products based on a number of technical specifications and narrows down the search to a few relevant products that meet the customer's need.

- Sliders/check boxes for different parameters like e.g pixel number, pixel dimension or max. line frequency etc.
- Selection of camera interface (GigE, GigEVision, Camera Link or USB 3.0)
- Selection of monochrome or color sensor
- Selection of lens mount
- Special features like active sensor length, integration control, anti-blooming, TDI, Extended gray scale

Technical details can be compared 1:1 by using the product comparison function.

The detailed specific product pages include:

- Detailed description
- Up-to-date technical data, download of data sheets
- Technical drawings including step files (step files for registered users only)
- Adequate accessories including tools, adapters etc.
- Extensive technotes section
- FAQs

Using the product configurator, all camera parameters can be found on the specific product pages.

The data on the website is updated frequently. If you want the latest information on our line scan cameras, please refer to [www.sukhamburg.com/products/linescancamera.html](http://www.sukhamburg.com/products/linescancamera.html)

## Example of the Product Configurator (<https://www.sukhamburg.com/products/linescancameras/configurator.htm>)

**Schafter+Kirchhoff**

Home Products Support About S+K Contact

**PRODUCT CONFIGURATOR**

Product Configurator for all Line Scan Cameras. Please use the check boxes and sliders to select certain features and narrow down your search to the specifications you need. Under advanced setting you will find more possibilities to specify your needs, e.g. spectral range or special features like anti-blooming.

**CONFIGURATOR**

Interface: GigE  Color  Pixel number: 6300 - 9000

Camera Name	Pixel Number	Pixel Dimension	Active Sensor Length	Max. line frequency	Anti-blooming	Integration control	Shading Correction	Threshold Mode	Interface	Bit depth	Compare
SK22368GTOC-4L	7456 x 3	4.7 x 4.7 µm	35.0 mm	5.1 kHz			X		GigE	3*8 Bit	<input type="checkbox"/>
SK22806GJRC-4XC	7600 x 3	9.3 x 9.3 µm	70.9 mm	5.0 kHz			X		GigE	3*8 Bit	<input type="checkbox"/>

**ADVANCED SETTINGS**





# Line Scan Cameras

**Line Scan Cameras  
Types, Interfaces, Casings  
and Dimensions**



## ■ Line Scan Cameras

Gigabit Ethernet, GigE Vision™ Cameras	20
USB3.0 Cameras	30
Camera Link Cameras	40
Casings and Dimensions	46

# Interface Gigabit Ethernet, GigE Vision



## Introduction

Gigabit Ethernet line scan cameras are especially suited for applications that require high data transfer rates or long cables. The high data transfer rates of up to 1000 Mbps make them suitable for many demanding image processing applications.

GigE cameras can also be used in many locations remote from the dedicated computer because the Gigabit Ethernet technology allows cable lengths of up to 100 m.

Schäfter+Kirchhoff offers a G-series and a V-series of line scan camera with a Gigabit Ethernet interface. The hardware is technically identical and they differ only in their respective firmware.

Cameras of the V-series are 100% GigE Vision compatible and programming is performed using the **GEN<i>CAM™** interface.

G-series cameras are not GigE Vision compliant and their major strengths are in high performance, flexibility and additional functionality beyond the GigE Vision norm.

Additional features include:

- customer-specific I/O signals in addition to video signal
- special preprocessing algorithms can be implemented in the camera
- SDK from Schäfter+Kirchhoff with libraries and examples.

### Gigabit Ethernet or GigE Vision?

If the application is developed using GigE Vision compliant software, for example LabVIEW, Common Vision Blox or Halcon then a line scan camera of the V series is recommended, as these cameras are supported by the software directly.

A line scan camera of the G series is recommended for customers planning to develop their own image processing routines, leaving them free to use alternative vision libraries like OpenCV. The G series is also the best choice when the application requires additional specific output control signals and more flexibility.



Quick and efficient product selection with the Product Configurator:  
[www.sukhamburg.com](http://www.sukhamburg.com)



## Features

	GigE (G-series)	GigE Vision (V-series)
Shading Correction	X	X
Programmable Lookup Table	X	X
Thresholding	X	-
Window Function (ROI)	X	X
Line Trigger, Frame Trigger	X	X
Frame Trigger Delay	X	X
Threshold Trigger	X	-
Advanced Synchronization Control	X	-
Integration Control for R, G, B	X	-
Decoupling of line frequency	X	-
Extra signals for diagnosis	X	-
Data cable length	100 m	100 m
Windows	SK91GigE-WIN SDK	SkGEVTool-WIN Tool
LabVIEW	-	NI-IMAQdx
Linux	-	SKGEVTool-LX Tool

## Connections and I/O Signals

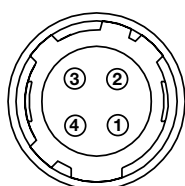

Pin	Signal	Pin	Signal
1	n.c.	3	n.c.
2	GND	4	min. +18 V max. +36 V

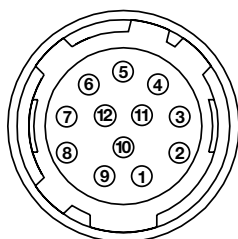

Pin	Signal*)	Pin	Signal*)
1	GND	10	LineSync A IN
8	FrameSync IN	6	LineSync B IN

\*) Signal Specification (TTL)

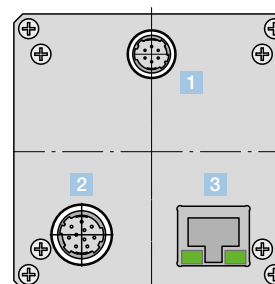

**1 Power +24 V**

Hirose series 10A, male 4-pin

**2 I/O Connector**

Hirose series 10A, male 12-pin

**3 Data**

RJ-45 connector for Gigabit Ethernet cable

# Overview: Gigabit Ethernet, GigE Vision

## Monochrome Cameras

Pos.	Order Code	Pixels	Active Length [mm]	Pixel Size [µm]	Max. Pixel Frequency [MHz]	Max. Line Frequency [kHz]	Dynamic Range (RMS)	Casing	Lens Mount	Sensor Technology	Anti-Blooming	Integration Control
1	SK1024VJR-4 SK1024GJR-4	1024	14.30	14 x 14	10	4.7	1:625	BG1	C-Mount	CCD	-	x
2	SK1024VSH-4 SK1024GSH-4	1024	14.30	14 x 14	30	27.0	1:2000	BG1	C-Mount	CCD	x	x
3	SK1024MVSH	1024	14.30	14 x 14	30	27.0	1:2500	RG1	C-Mount	CCD	x	x
4	SK2048VHA-4 SK2048GHA-4	2048	16.38	8 x 8	120	52.6	1:2500	BG1	C-Mount	CCD	x	x
5	SK2048VJR-4L SK2048GJR-4L	2048	28.70	14 x 14	10	4.7	1:625	BG3	M45x0.75	CCD	-	x
6	SK2048VSH-4L SK2048GSH-4L	2048	28.70	14 x 14	30	14.0	1:2000	BG3	M45x0.75	CCD	x	x
7	SK2048MVSH	2048	28.70	14 x 14	30	14.1	1:2500	RG2	M40x0.75	CCD	x	x
8	SK5150VJR-4L SK5150GJR-4L	5152	36.00	7 x 7	40	7.5	1:500	BG3	M45x0.75	CCD	-	-
9	SK7456VTO-4L SK7456GTO-4L	7456	35.04	4.7 x 4.7	40	5.2	1:1000	BG3	M45x0.75	CCD	-	-
10	SK7500VTO-4XL SK7500GTO-4XL	7496	52.50	7 x 7	40	5.2	1:750	CG5	M72x0.75	CCD	-	-
11	SK7500VTF-4XB SK7500GTF-4XB	7496	52.50	7 x 7	65	8.3	1:1000	EG5	M72x0.75	CCD	-	-
12	SK8160VKO-4LB SK8160GKO-4LB	8160	40.80	5 x 5	100	11.9	1:2500	BG3	M45x0.75	CCD	x	x
13	SK8160VKO-4XL SK8160GKO-4XL	8160	40.80	5 x 5	100	11.9	1:2500	CG5	M72x0.75	CCD	x	x

CMOS sensors, rectangular pixel shape, especially suitable for spectroscopy applications

14	SK2048MVHW	2048	28.70	14 x 200	10	4.6	1:2500	RG2	M40x0.75	CMOS	x	x
15	SK4096MVHW	4096	28.70	7 x 200	10	2.4	1:2500	RG2	M40x0.75	CMOS	x	x

## Color Cameras

Pos.	Order Code	Pixels	Active Length [mm]	Pixel Size [µm]	Max. Pixel Frequency [MHz]	Max. Line Frequency [kHz]	Dynamic Range (RMS)	Casing	Lens Mount	Sensor Technology	Anti-Blooming	Integration Control
1	SK6288VKOC-4L SK6288GKOC-4L	2096 x 3	29.30	14 x 14	60	9.3	1:2500	BG3	M45x0.75	CCD	-	x
2	SK8100VJRC-4L SK8100GJRC-4L	2696 x 3	21.60	8 x 8	24	2.9	1:2000	BG3	M45x0.75	CCD	-	x
3	SK10944VJRC-4L SK10944GJRC-4L	3648 x 3	29.20	8 x 8	24	2.1	1:2000	BG3	M45x0.75	CCD	-	x
4	SK12240VKOC-4LB SK12240GKOC-4LB	4080 x 3	40.80	10 x 10	60	7.2	1:2500	BG3	M45x0.75	CCD	x	x
5	SK12240VKOC-4XL SK12240GKOC-4XL	4080 x 3	40.80	10 x 10	60	7.2	1:2500	CG5	M72x0.75	CCD	x	x
6	SK16080VJRC-4L SK16080GJRC-4L	5360 x 3	42.90	8 x 8	24	1.5	1:2000	BG3	M45x0.75	CCD	-	x
7	SK16200VTOC-4L SK16200GTOC-4L	5400 x 3	37.80	7 x 7	120	6.9	1:1250	BG3	M45x0.75	CCD	-	-
8	SK22368VTOC-4L SK22368GTOC-4L	7456 x 3	35.04	4.7 x 4.7	120	5.1	1:1000	BG3	M45x0.75	CCD	-	-
9	SK22800VJRC-4XC SK22800GJRC-4XC	7600 x 3	70.87	9.3 x 9.3	120	4.9	1:1000	FG7	Ø80 H8	CCD	-	-

Casings and dimensions ► page 46

Detailed data sheets, up-to-date technical information, technical drawings including step files, accessories, extensive technotes section and FAQs:  
[www.sukhamburg.com](http://www.sukhamburg.com)



## Accessories: GigE, GiGE Vision

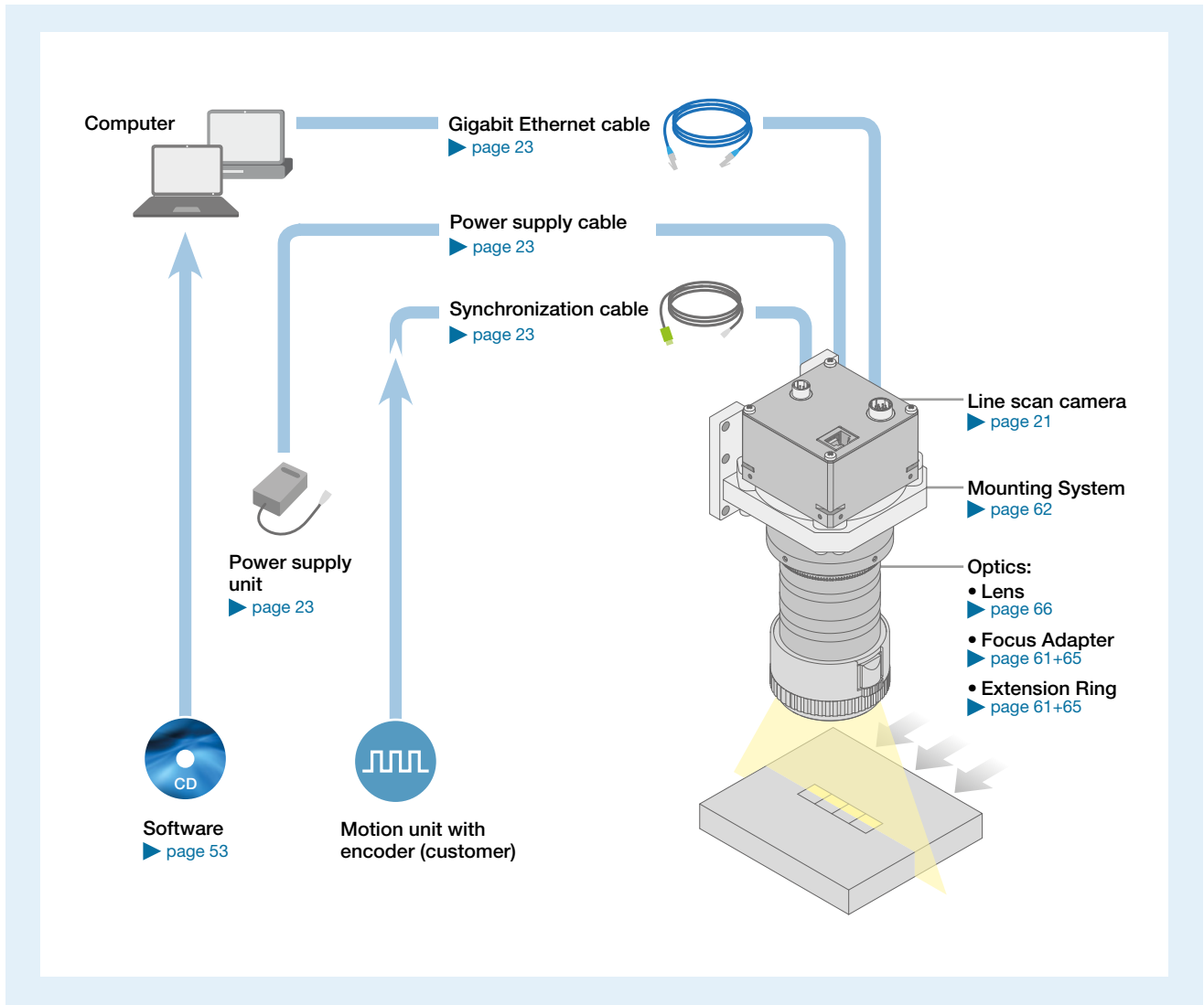

## Application Parallel Image Acquisition

with several GigE line scan cameras using a GigE switch

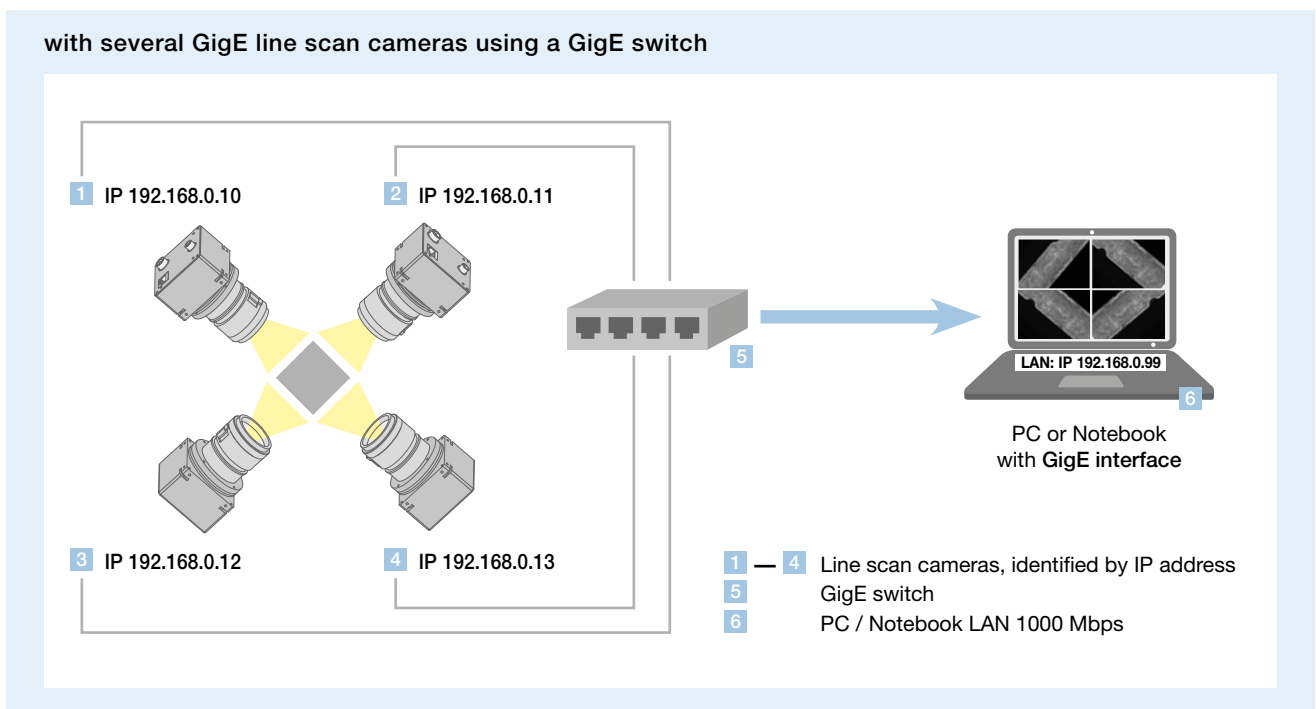

## Software



**SkLineScan** operating program (supplied)  
**SK91GigEconfig** tool (supplied)



**SK91GigE-WIN** Order Code

SDK from Schäfter+Kirchhoff including the API, C++ class library and examples.

Operating systems:

Windows 7 / 8.1 / 10 - x64, x86



The Schäfter+Kirchhoff GigE Vision™ line scan cameras use the Gigabit Ethernet communication protocol and are 100% compliant with the GigE Vision™ specifications and the Gen<|>Cam™

standard. They implement a superset of the Gen<|>Cam™ specifications that define the device capabilities. The settings are made in the device feature list of any Gen<|>Cam™ compliant software.

The Gen<|>Cam™ standard provides a generic programming interface for all kinds of camera so that, no matter what features they implement, the application programming interface (API) always remains the same.

## Electrical Installation Connection Cables and Power Supply



### CAT6 Network cable

Shielded CAT6 patch cable, halogen-free, both ends with RJ45 connectors for Gigabit Ethernet

**CAT6.x** Order Code

cable length 3 / 5 / 10 m or length according to choice, max. 100 m



### Power cable SK9014.xF

for GigE line scan cameras with 24 V DC supply voltage.

Shielded cable with Hirose plug HR10A, female 4-pin (camera side), and open-ended lines.

**SK9014.xF** Order Code

cable length 1.5 / 3 / 5 m.



### External synchronization cable SK9024...

for line scan cameras with GigE / GigE Vision™ interface.

Shielded cable with Hirose plug HR10A, female 12-pin (camera side), and Phoenix 4-pin connector incl. terminal block.

**SK9024.x** Order Code

cable length 3 / 5 m  
 Other lengths on request



### Power cable SK9014.xMF

for GigE line scan cameras with 24 V DC supply voltage.

Shielded cable with Hirose plug HR10A, female 4-pin (camera side), and XLR connector type NC6MXX.

**SK9014.xMF** Order Code

cable length 1.5 / 3 / 5 m.



### Adapter cable for sync signals CAB-AD Sync-BNC-1

BNC/SMA (3x) to Line Scan Camera Synchronization Cable SK9016/SK9024/SK9026. Shielded cable, length 0.25 m

#### Connectors:

- 1x Phoenix 4-pin connector
- 3x SMA plug  
(Line Sync A, Line Sync B, Frame Sync)
- 3x adapter SMA socket  
(outside threading) to BNC-plug

**CAB-AD Sync-BNC-1** Order Code



### Power supply unit PS243005

Input: 100-240 V AC, 0.8 A, 50/60 Hz  
 IEC 60320 C14 coupler  
 (for IEC C13 power cord)

Output: +24 V DC, 3.0 A

Cable length: 1 m,  
 with XLR connector type NC6FXX  
**PS243005** Order Code

Power cord IEC 60320 C13,  
 1.5 m, 10 A, 250 V AC

**PC150DE** Order Code

DE = Europe  
 US = USA, Canada, Japan  
 UK = United Kingdom



DE



US



UK

# Line Scan Cameras: Gigabit Ethernet, GigE Vision

Camera Types: Monochrome

1

mono  
chrome

CCD



## SK1024GJR-4 SK1024VJR-4

Line scan camera with high sensitivity, spectral range 400 to 900 nm, and 4.73 kHz maximum line rate.

Lens mount	C-Mount
Camera Casing	BG1

Supply Voltage	18 - 36 V DC
Power	3.0 W

Pixels, dimension	1024, 14 x 14 $\mu\text{m}^2$
Sensor length	14.30 mm
Max. line frequency	4.7 kHz
Pixel frequencies	10 MHz
Exposure time	0.01 ... 20 ms
Spectral range	400 ... 900 nm
Dynamic range	1:625 (rms)
Special features	Integration control
Pixel data format	8/12 Bit

2

mono  
chrome

CCD



## SK1024GSH-4 SK1024VSH-4

Line scan camera with 27 kHz maximum line rate, large dynamic range, anti blooming and integration control.

Lens mount	C-Mount
Camera Casing	BG1

Supply Voltage	18 - 36 V DC
Power	4.3 W

Pixels, dimension	1024, 14 x 14 $\mu\text{m}^2$
Sensor length	14.30 mm
Max. line frequency	27.0 kHz
Pixel frequencies	30 or 20 MHz
Exposure time	0.01 ... 20 ms
Spectral range	200 ... 1000 nm
Dynamic range	1:2000 (rms)
Special features	Anti blooming, integration control
Pixel data format	8/12 Bit

3

mono  
chrome

CCD



## SK1024MVSH

Line scan camera with large dynamic range and 27 kHz maximum line rate, anti blooming and integration control.

Lens mount	C-Mount
Camera Casing	RG1

Supply Voltage	8 - 16 V DC
Power	3.9 W

Pixels, dimension	1024, 14 x 14 $\mu\text{m}^2$
Sensor length	14.30 mm
Max. line frequency	27.0 kHz
Pixel frequencies	30 or 20 MHz
Exposure time	0.01 ... 20 ms
Spectral range	200 ... 1000 nm
Dynamic range	1:2500 (rms)
Special features	Anti blooming, integration control
Pixel data format	8/12 Bit

4

mono  
chrome

CCD

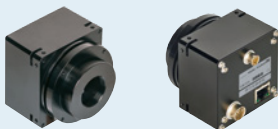

## SK2048GHA-4 SK2048VHA-4

Line scan camera, high speed with 52.63 kHz maximum line rate, spectral range of 200 to 1000 nm.

Lens mount	C-Mount
Camera Casing	BG1

Supply Voltage	18 - 36 V DC
Power	5.4 W

Pixels, dimension	2048, 8 x 8 $\mu\text{m}^2$
Sensor length	16.38 mm
Max. line frequency	52.6 kHz
Pixel frequencies	120 or 60 MHz
Exposure time	0.01 ... 20 ms
Spectral range	200 ... 1000 nm
Dynamic range	1:2500 (rms)
Special features	Anti blooming, integration control
Pixel data format	8/12 Bit

5

mono  
chrome

CCD



## SK2048GJR-4L SK2048VJR-4L

Line scan camera with high sensitivity and 4.73 kHz maximum line rate.

Lens mount	M45x0.75
Camera Casing	BG3

Supply Voltage	18 - 36 V DC
Power	3.8 W

Pixels, dimension	2048, 14 x 14 $\mu\text{m}^2$
Sensor length	28.70 mm
Max. line frequency	4.7 kHz
Pixel frequencies	10 MHz
Exposure time	0.01 ... 20 ms
Spectral range	400 ... 900 nm
Dynamic range	1:625 (rms)
Special features	Integration control
Pixel data format	8/12 Bit



# Line Scan Cameras: Gigabit Ethernet, GigE Vision

## Camera Types: Monochrome *continued*

6

mono  
chrome

CCD



Lens mount	M45x0.75
Camera Casing	BG3

### SK2048GSH-4L SK2048VSH-4L

Line scan camera with large dynamic range and 14.3 kHz maximum line rate, anti blooming and integration control.

Supply Voltage	18 - 36 V DC
Power	5.5 W

Pixels, dimensions	2048, 14 x 14 $\mu\text{m}^2$
Sensor length	28.70 mm
Max. line frequency	14.0 kHz
Pixel frequencies	30 or 20 MHz
Exposure time	0.01 ... 20 ms
Spectral range	200 ... 1000 nm
Dynamic range	1:2000 (rms)
Special features	Anti blooming, integration control
Pixel data format	8/12 Bit

7

mono  
chrome

CCD



Lens mount	M40x0.75
Camera Casing	RG2

### SK2048MVSH

Line scan camera with large dynamic range and 14.1 kHz maximum line rate, anti blooming and integration control.

Supply Voltage	8 - 16 V DC
Power	4.4 W

Pixels, dimensions	2048, 14 x 14 $\mu\text{m}^2$
Sensor length	28.70 mm
Max. line frequency	14.1 kHz
Pixel frequencies	30 or 20 MHz
Exposure time	0.01 ... 20 ms
Spectral range	200 ... 1000 nm
Dynamic range	1:2500 (rms)
Special features	Anti blooming, integration control
Pixel data format	8/12 Bit

8

mono  
chrome

CCD



Lens mount	M45x0.75
Camera Casing	BG3

### SK5150GJR-4L SK5150VJR-4L

Line scan camera with very high sensitivity, 7.56 kHz maximum line rate.

Supply Voltage	18 - 36 V DC
Power	5.4 W

Pixels, dimensions	5148, 7 x 7 $\mu\text{m}^2$
Sensor length	36.00 mm
Max. line frequency	7.6 kHz
Pixel frequencies	40 or 20 MHz
Exposure time	0.133 ... 20 ms
Spectral range	400 ... 900 nm
Dynamic range	1:500 (rms)
Special features	Integration control
Pixel data format	8/12 Bit

9

mono  
chrome

CCD



Lens mount	M45x0.75
Camera Casing	BG3

### SK7456GTO-4L SK7456VTO-4L

Line scan camera with high sensitivity, small pixel size and short sensor length, 5.2 kHz maximum line rate.

Supply Voltage	18 - 36 V DC
Power	4.0 W

Pixels, dimensions	7456, 4.7 x 4.7 $\mu\text{m}^2$
Sensor length	35.04 mm
Max. line frequency	5.2 kHz
Pixel frequencies	40 or 20 MHz
Exposure time	0.19 ... 20 ms
Spectral range	400 ... 900 nm
Dynamic range	1:1000 (rms)
Special features	
Pixel data format	8/12 Bit

10

mono  
chrome

CCD

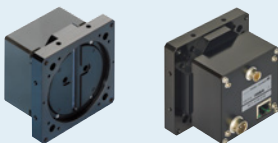

Lens mount	M72x0.75
Camera Casing	CG5

### SK7500GTO-4XL SK7500VTO-4XL

Line scan camera with 5.2 kHz maximum line rate, high resolution and high sensitivity.

Supply Voltage	18 - 36 V DC
Power	3.8 W

Pixels, dimensions	7500, 7 x 7 $\mu\text{m}^2$
Sensor length	52.50 mm
Max. line frequency	5.2 kHz
Pixel frequencies	40 or 15 MHz
Exposure time	0.192 ... 20 ms
Spectral range	400 ... 900 nm
Dynamic range	1:750 (rms)
Special features	
Pixel data format	8/12 Bit

# Line Scan Cameras: Gigabit Ethernet, GigE Vision

## Camera Types: Monochrome *continued*

11

mono  
chrome

CCD

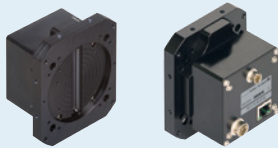

Lens mount	M72x0.75
Camera Casing	EG5

### SK7500GTF-4XB SK7500VTF-4XB

Line scan camera with 8.26 kHz maximum line rate, high resolution and high sensitivity.

Supply Voltage	18 - 36 V DC
Power	7.0 W

Pixels, dimensions	7500, 7 x 7 $\mu\text{m}^2$
Sensor length	52.50 mm
Max. line frequency	8.3 kHz
Pixel frequencies	65 or 15 MHz
Exposure time	0.121 ... 20 ms
Spectral range	400 ... 900 nm
Dynamic range	1:1000 (rms)
Special features	
Pixel data format	8/12 Bit

12

mono  
chrome

CCD



Lens mount	M45x0.75
Camera Casing	BG3

### SK8160GKO-4LB SK8160VKO-4LB

High resolution line scan camera with 11.9 kHz maximum line rate, anti blooming and integration control.

Supply Voltage	18 - 36 V DC
Power	4.4 W

Pixels, dimensions	8160, 5 x 5 $\mu\text{m}^2$
Sensor length	40.80 mm
Max. line frequency	11.9 kHz
Pixel frequencies	100 or 30 MHz
Exposure time	0.01 ... 20 ms
Spectral range	350 ... 900 nm
Dynamic range	1:2500 (rms)
Special features	Anti blooming, integration control
Pixel data format	8/12 Bit

13

mono  
chrome

CCD



Lens mount	M72x0.75
Camera Casing	CG5

### SK8160GKO-4XL SK8160VKO-4XL

High resolution line scan camera with 11.9 kHz maximum line rate, anti blooming and integration control.

Supply Voltage	18 - 36 V DC
Power	4.4 W

Pixels, dimensions	8160, 5 x 5 $\mu\text{m}^2$
Sensor length	40.80 mm
Max. line frequency	11.9 kHz
Pixel frequencies	100 or 30 MHz
Exposure time	0.01 ... 20 ms
Spectral range	350 ... 900 nm
Dynamic range	1:2500 (rms)
Special features	Anti blooming, integration control
Pixel data format	8/12 Bit

## Camera Types: Monochrome, CMOS, for spectrophotometry

14

mono  
chrome

CMOS

RECT  
ANGLE



Lens mount	M40x0.75
Camera Casing	RG2

### SK2048MVHW

CMOS line scan camera, spectral range 200 to 1000 nm, 4.6 kHz line rate, rectangular pixel shape, suitable for spectrophotometry.

Supply Voltage	5 - 16 V DC
Power	2.5 W

Pixels, dimensions	2048, 14 x 200 $\mu\text{m}^2$
Sensor length	28.70 mm
Max. line frequency	4.6 kHz
Pixel frequencies	10 MHz
Exposure time	0.01 ... 20 ms
Spectral range	200 ... 1000 nm
Dynamic range	1:2500 (rms)
Special features	Anti blooming, integration control
Pixel data format	8/12 Bit

15

mono  
chrome

CMOS

RECT  
ANGLE



Lens mount	M40x0.75
Camera Casing	RG2

### SK4096MVHW

CMOS line scan camera, spectral range 200 to 1000 nm, 2.38 kHz line rate, rectangular pixel shape, suitable for spectrophotometry.

Supply Voltage	5 - 16 V DC
Power	2.5 W

Pixels, dimensions	4096, 7 x 200 $\mu\text{m}^2$
Sensor length	28.70 mm
Max. line frequency	2.4 kHz
Pixel frequencies	10 MHz
Exposure time	0.01 ... 20 ms
Spectral range	200 ... 1000 nm
Dynamic range	1:2500 (rms)
Special features	Anti blooming, integration control
Pixel data format	8/12 Bit

# Line Scan Cameras: Gigabit Ethernet, GigE Vision

## Camera Types: Color

**1**





**SK6288GKOC-4L**  
**SK6288VKOC-4L**

Color line scan camera (Triple-Line) with 3 x 2096 RGB pixels, 9.28 kHz maximum line rate, integration control.

Pixels, dimensions	2096 x 3, 14 x 14 μm²
Sensor length	29.30 mm
Max. line frequency	9.3 kHz
Pixel frequencies	60 or 30 MHz
Exposure time	0.01 ... 20 ms
Spectral range	400 ... 700 nm
Dynamic range	1:2500 (rms)
Special features	Integration control
Pixel data format	8/12 Bit
Line spacing, color sequence	112 μm, BGR

Lens mount	M45x0.75
Camera Casing	BG3

Supply Voltage	18 - 36 V DC
Power	5.4 W

**2**





**SK8100GJRC-4L**  
**SK8100VJRC-4L**

Color line scan camera (Triple-Line) with 3 x 5360 RGB pixels, 2.86 kHz maximum line rate, integration control.

Pixels, dimensions	2700 x 3, 8 x 8 μm²
Sensor length	21.60 mm
Max. line frequency	2.9 kHz
Pixel frequencies	24 or 15 MHz
Exposure time	0.01 ... 20 ms
Spectral range	400 ... 700 nm
Dynamic range	1:2000 (rms)
Special features	Integration control
Pixel data format	8/12 Bit
Line spacing, color sequence	64 μm, RGB

Lens mount	M45x0.75
Camera Casing	BG3

Supply Voltage	18 - 36 V DC
Power	3.8 W

**3**





**SK10944GJRC-4L**  
**SK10944VJRC-4L**

Color line scan camera (Triple-Line) with 3 x 3648 RGB pixels, 2.14 kHz maximum line rate, integration control.

Pixels, dimensions	3648 x 3, 8 x 8 μm²
Sensor length	29.20 mm
Max. line frequency	2.1 kHz
Pixel frequencies	24 or 15 MHz
Exposure time	0.01 ... 20 ms
Spectral range	400 ... 700 nm
Dynamic range	1:2000 (rms)
Special features	Integration control
Pixel data format	8/12 Bit
Line spacing, color sequence	64 μm, RGB

Lens mount	M45x0.75
Camera Casing	BG3

Supply Voltage	18 - 36 V DC
Power	3.8 W

**4**





**SK12240GKOC-4LB**  
**SK12240VKOC-4LB**

Color line scan camera (Triple-Line) with 3 x 4080 RGB pixels, 7.2 kHz maximum line rate, anti blooming, integration control.

Pixels, dimensions	4080 x 3, 10 x 10 μm²
Sensor length	40.80 mm
Max. line frequency	7.2 kHz
Pixel frequencies	60 or 30 MHz
Exposure time	0.01 ... 20 ms
Spectral range	400 ... 700 nm
Dynamic range	1:2500 (rms)
Special features	Anti blooming, integration control
Pixel data format	8/12 Bit
Line spacing, color sequence	90 μm, GRB

Lens mount	M45x0.75
Camera Casing	BG3

Supply Voltage	18 - 36 V DC
Power	9.0 W

**5**



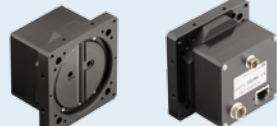

**SK12240GKOC-4XL**  
**SK12240VKOC-4XL**

Color line scan camera (Triple-Line) with 3 x 4080 RGB pixels, 7.2 kHz maximum line rate, anti blooming, integration control.

Pixels, dimensions	4080 x 3, 10 x 10 μm²
Sensor length	40.80 mm
Max. line frequency	7.2 kHz
Pixel frequencies	60 or 30 MHz
Exposure time	0.01 ... 20 ms
Spectral range	400 ... 700 nm
Dynamic range	1:2500 (rms)
Special features	Anti blooming, integration control
Pixel data format	8/12 Bit
Line spacing, color sequence	90 μm, GRB

Lens mount	M72x0.75
Camera Casing	CG5

Supply Voltage	18 - 36 V DC
Power	9.0 W

# Line Scan Cameras: Gigabit Ethernet, GigE Vision

## Camera Types: Color *continued*

6



Lens mount	M45x0.75
Camera Casing	BG3

### SK16080GJRC-4L SK16080VJRC-4L

Color line scan camera (Triple-Line) with 3 x 5360 RGB pixels  
24 MHz pixel frequency, integration control

Supply Voltage	18 - 36 V DC
Power	3.8 W

Pixels, dimensions	5360 x 3, 8 x 8 $\mu\text{m}^2$
Sensor length	42.90 mm
Max. line frequency	1.5 kHz
Pixel frequencies	24 or 15 MHz
Exposure time	0.01 ... 20 ms
Spectral range	400 ... 700 nm
Dynamic range	1:2000 (rms)
Special features	Integration control
Pixel data format	8/12 Bit
Line spacing, color sequence	64 $\mu\text{m}$ , RGB

7



Lens mount	M45x0.75
Camera Casing	BG3

### SK16200GTOC-4L SK16200VTOC-4L

Color line scan camera (Triple-Line) with 3 x 5400 RGB pixels,  
7 kHz maximum line rate.

Supply Voltage	18 - 36 V DC
Power	6.9 W

Pixels, dimensions	5400 x 3, 7 x 7 $\mu\text{m}^2$
Sensor length	37.80 mm
Max. line frequency	6.9 kHz
Pixel frequencies	120 or 60 MHz
Exposure time	0.143 ... 20 ms
Spectral range	400 ... 700 nm
Dynamic range	1:1250 (rms)
Special features	
Pixel data format	3*8 Bit
Line spacing, color sequence	28 $\mu\text{m}$ , RGB

8



Lens mount	M45x0.75
Camera Casing	BG3

### SK22368GTOC-4L SK22368VTOC-4L

Color line scan camera (Triple-Line) with 3 x 7456 RGB pixels,  
5.13 kHz maximum line rate, small pixel size and short sensor length.

Supply Voltage	18 - 36 V DC
Power	6.9 W

Pixels, dimensions	7456 x 3, 4.7 x 4.7 $\mu\text{m}^2$
Sensor length	35.04 mm
Max. line frequency	5.1 kHz
Pixel frequencies	120 or 60 MHz
Exposure time	0.195 ... 20 ms
Spectral range	350 ... 700 nm
Dynamic range	1:1000 (rms)
Special features	
Pixel data format	3*8 Bit
Line spacing, color sequence	18.8 $\mu\text{m}$ , RGB

9



Lens mount	Ø80 H8
Camera Casing	FG7

### SK22800GJRC-4XC SK22800VJRC-4XC

Color line scan camera (Triple-Line) with 3 x 7600 RGB pixels,  
4.93 kHz maximum line rate, high resolution.

Supply Voltage	18 - 36 V DC
Power	8.8 W

Pixels, dimensions	7600 x 3, 9.3 x 9.3 $\mu\text{m}^2$
Sensor length	70.87 mm
Max. line frequency	4.9 kHz
Pixel frequencies	120 or 60 MHz
Exposure time	0.202 ... 20 ms
Spectral range	350 ... 680 nm
Dynamic range	1:1000 (rms)
Special features	Integration control
Pixel data format	3*8 Bit
Line spacing, color sequence	9.3 $\mu\text{m}$ , BGR

Detailed data sheets, up-to-date technical information, technical drawings including step files, accessories, extensive technotes section and FAQs:  
[www.sukhamburg.com](http://www.sukhamburg.com)





# Interface USB 3.0



## Introduction

USB 3.0 line scan cameras are ideally suited for fast and high-resolution scanning. The plug&play capability predestine the USB 3.0 line scan cameras for use in mobile scanner applications, either controlled by a laptop or when the controlling PC is often changed. The locking screw on the connectors and an industrial housing design make them robust and suitable for industrial environments. By using standard components, these USB 3.0 camera systems are comparatively inexpensive and provide a beneficial price-performance ratio. An external grabber is not required. Most of the USB 3.0 cameras are satisfied by the integral USB power. An external power supply is only necessary for some high performance cameras with higher power consumption.

In combination with the Smart-Control-Box, the USB 3.0 cameras can be used as line sensors to provide fast and stand-alone measurement systems, e.g. for measuring object widths, the diameter or edges of a rod as well as the thickness of transparent materials such as glass.

- High performance cameras for industry and laboratory
- High value-for-money ratio
- Securely attached connectors, robust casings
- No external power supply needed for most cameras
- USB 3.0 SuperSpeed enables the use of sensors at their maximum line frequencies
- Default cable length of up to 3 m
- Active Optical Cable can be up to 100 m long
- Advanced Synchronization Control
- Software for Windows 7, 8.1, 10 - x64, x86 or for Linux kernel 3.13+
- Useable as sensor for the Smart-Control-Box
- Downwards compatible with USB 2.0



Quick and efficient product selection with the Product Configurator:  
[www.sukhamburg.com](http://www.sukhamburg.com)



## Features

Line frequency	max. 53.5 kHz
Shading correction with permanently stored profiles	X
Programmable Lookup Table	X
Window Function (ROI)	X
Line Trigger, Frame Trigger, Threshold Trigger	X
Advanced Synchronization Control	X
Thresholding	all monochrome models
Status LED for power-on (red) and firmware loaded (green)	X
Extra signals for diagnosis (line counter, sync status)	X
Data cable length (default)	3 m
Extended length when using Active Optical Cable, up to	100m
Software, SDK for Windows, Linux	SkLineScan, SK91USB3-WIN, SK91USB3-LX
LabVIEW	SK91USB3-LV VI Library

## Connections and I/O Signals

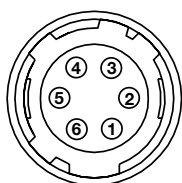

Pin	Signal	Pin	Signal
1	Line Sync B	4	+5 V *
2	+15 V *	5	Line Sync A
3	Frame Sync	6	GND

\* from external power supply unit  
 Line Sync A/B and Frame Sync: TTL levels

### 1 Data and power

USB 3.0 socket micro-B with threaded holes for locking screws

### 2 Synchronization and power\*

Power: 2.5 W  
 Socket: Hirose series 10A, male 6-pin

### 3 Status indicator

- off no power, check connection to the external power supply unit
- red power on
- green power on, firmware is loaded, camera is ready

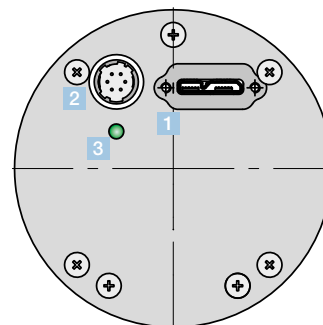

Most USB 3.0 cameras are driven by the integral USB power. An additional external power supply is necessary if the power consumption of the camera exceeds 4.5 Watt (USB 3.0) or 2.5 Watt (USB 2.0).

# Overview: USB 3.0

## Monochrome Cameras

Pos.	Order Code	Pixels	Active Length [mm]	Pixel Size [μm]	Max. Pixel Frequency [MHz]	Max. Line Frequency [kHz]	Dynamic Range (RMS)	Casing	Lens Mount	Sensor Technology	Anti-Blooming	Integration Control
1	SK512U3SH	512	7.17	14 x 14	30	35.7	1:2000	AT1	C-Mount	CCD	x	x
2	SK1024U3HA	1024	8.17	8 x 8	120	52.6	1:2500	AT1	C-Mount	CCD	x	x
3	SK1024U3SH	1024	14.30	14 x 14	30	27.0	1:2500	AT1	C-Mount	CCD	x	x
4	SK2048U3HA	2048	16.38	8 x 8	120	52.6	1:2500	AT1	C-Mount	CCD	x	x
5	SK2048U3JR	2048	28.70	14 x 14	10	4.7	1:1000	AT2	M40x0.75	CCD	-	x
6	SK2048U3SH	2048	28.70	14 x 14	30	14.0	1:2500	AT2	M40x0.75	CCD	x	x
7	SK5150U3JR	5148	36.00	7 x 7	40	7.6	1:1000	AT2	M40x0.75	CCD	-	-
8	SK7456U3TO	7456	35.04	4.7 x 4.7	40	5.2	1:1000	AT2	M40x0.75	CCD	-	-
9	SK7500U3TO-XL	7500	52.50	7 x 7	40	5.2	1:1000	CT5	M72x0.75	CCD	-	-
10	SK7500U3TF-XB	7500	52.50	7 x 7	80	10.1	1:1000	ET5	M72x0.75	CCD	-	-
11	SK8160U3KO-LB	8160	40.80	5 x 5	100	11.9	1:2000	AT3L	M45x0.75	CCD	x	x

CMOS sensors, rectangular pixel shape, especially suitable for spectroscopy applications

12	SK512U3HU	512	12.80	25 x 500	15	26.3	1:5000	AT1	C-Mount	CMOS	x	x
13	SK1024U3HU	1024	12.80	12.5 x 500	15	13.9	1:5000	AT1	C-Mount	CMOS	x	x
14	SK1024U3HV	1024	25.60	25 x 500	15	13.9	1:5000	AT2	M40x0.75	CMOS	x	x
15	SK2048U3HU	2048	25.60	12.5 x 500	15	7.1	1:5000	AT2	M40x0.75	CMOS	x	x
16	SK2048U3HW	2048	28.67	14 x 200	15	6.9	1:2000	AT2	M40x0.75	CMOS	x	x
17	SK4096U3HW	4096	28.67	7 x 200	10	2.4	1:5000	AT2	M40x0.75	CMOS	x	x

## Color Cameras

Pos.	Order Code	Pixels	Active Length [mm]	Pixel Size [μm]	Max. Pixel Frequency [MHz]	Max. Line Frequency [kHz]	Dynamic Range (RMS)	Casing	Lens Mount	Sensor Technology	Anti-Blooming	Integration Control
1	SK6288U3KOC	2096 x 3	29.30	14 x 14	60	9.3	1:2500	AT2	M40x0.75	CCD	-	x
2	SK8100U3JRC	2700 x 3	21.60	8 x 8	24	2.9	1:2000	AT2	M40x0.75	CCD	-	x
3	SK10944U3JRC	3648 x 3	29.20	8 x 8	24	2.1	1:2000	AT2	M40x0.75	CCD	-	x
4	SK12240U3KOC-LB	4080 x 3	40.80	10 x 10	60	7.2	1:2500	AT3L	M45x0.75	CCD	x	x
5	SK16080U3JRC-L	5360 x 3	42.90	8 x 8	24	1.5	1:2000	AT3	M45x0.75	CCD	-	x
6	SK16200U3TOC	5400 x 3	37.80	7 x 7	150	8.7	1:1250	AT2	M40x0.75	CCD	-	-
7	SK22368U3TOC	7456 x 3	35.04	4.7 x 4.7	150	6.4	1:1000	AT2	M40x0.75	CCD	-	-
8	SK22800U3JRC-XC	7600 x 3	70.87	9.3 x 9.3	150	6.2	1:1000	FT7	Ø80 H8	CCD	-	-

Casings and dimensions [▶ page 48](#)

Detailed data sheets, up-to-date technical information, technical drawings including step files, accessories, extensive technotes section and FAQs:  
[www.sukhamburg.com](http://www.sukhamburg.com)



### Connectors with locking screw

Rear view of the USB 3.0 line scan camera with USB 3.0 socket. The USB 3.0 micro-B connectors are provided with a secure locking screw. The line scan camera order should specify the desired USB 3.0 cable. The Hirose connector provides input for external synchronization control and for the external power supply, if required.



### USB 3.0 comparison with other common interfaces

Interface	External synchronization	Shading Correction	Max. Pixel frequency	External power required	Data cable length	PC Interface	System cost
	X	X	120 MHz	—	3m	USB3.0	low
	X	X	150 MHz	2.9	100m	Gigabit Ethernet	medium
	X	X	210 MHz (3 x 70 MHz)	6.2	10m	PCI/PCIe -slot	high

The major characteristics of the USB 3.0 interface can be compared with a representative set of modern line scan camera interfaces. USB 3.0 offers fast data transfer at relatively low system costs while providing a future-proof operation of the line scan camera at its maximum bit-depth and speed.

# Accessories: USB3.0

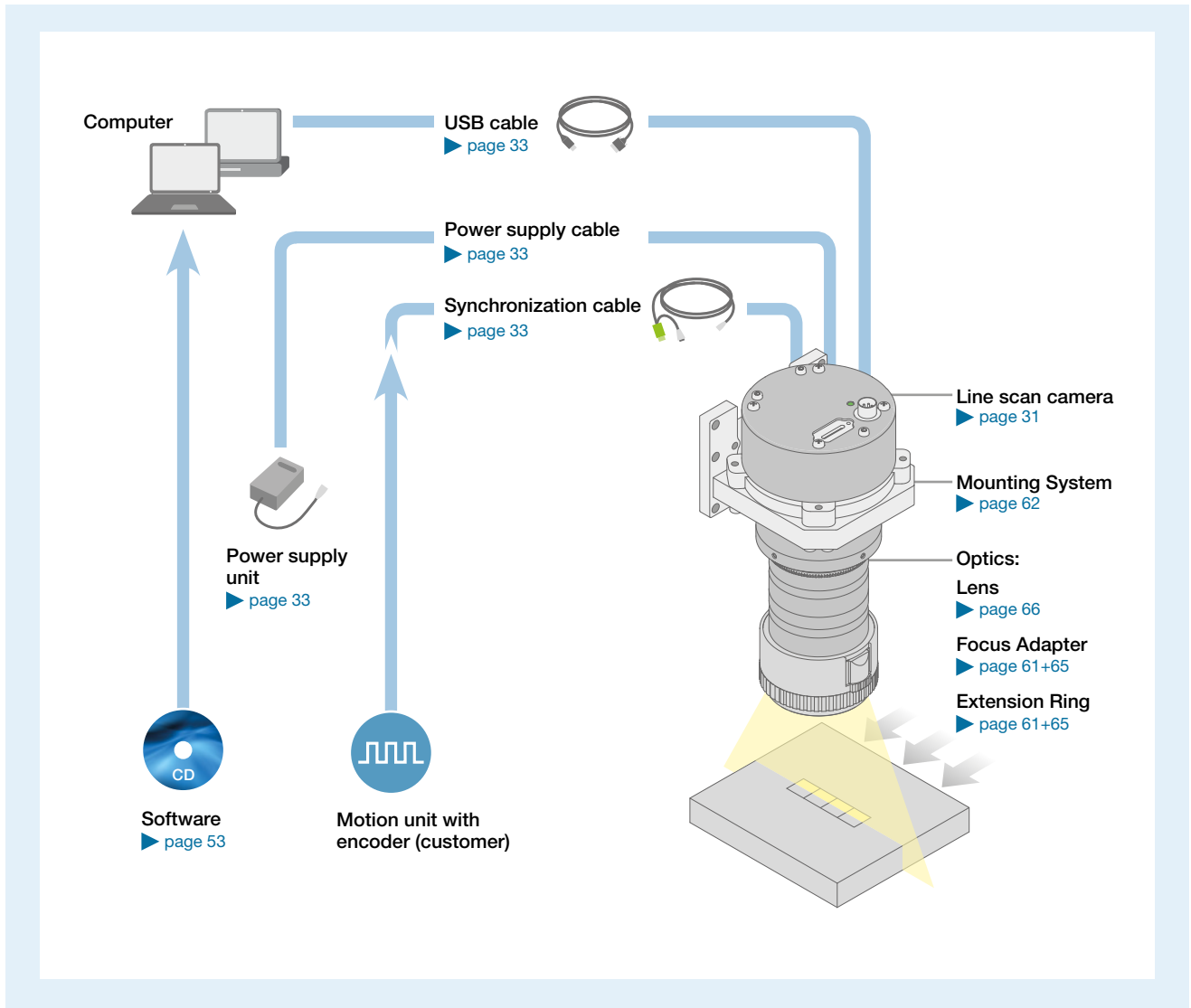

## Software

	<p><b>SkLineScan</b> operating program (supplied)</p>		<p><b>SkLineScan</b> operating program (supplied)</p>
	<p><b>SK91USB3-WIN</b> <span style="background-color: #FFD700;">Order Code</span></p> <p>SDK from Schäfter+Kirchhoff including the API, C++ class library and examples.</p> <p>Operating systems: Windows 7 / 8.1 / 10 - x64,</p>		<p><b>SK91USB3-LX</b> <span style="background-color: #FFD700;">Order Code</span></p> <p>SDK from Schäfter+Kirchhoff including the libraries and examples.</p> <p>Operating systems: Linux kernel 3.13 or higher</p>
	<p><b>SK91USB3-LV VI</b> <span style="background-color: #FFD700;">Order Code</span></p> <p>VI-Library for LabVIEW®, requires SK91USB3-WIN</p>		



# Electrical Installation: Connection Cables and Power Supply



### USB 3.0 cable SK9020.x

Camera connector:  
USB 3.0 plug, type micro-B, with safety lock screws

PC connector:  
USB 3.0 plug, type A (also fits into USB 2.0 type A socket)

**SK9020.x** **Order Code**  
 1 = 1 m cable length  
 3 = 3 m cable length (standard)



### USB 3.0 active extension cable USB3.EXT.A2A...

Hybrid cable (copper/fiber), power supply uses a separate USB connection, cable lengths up to 100 m on request.

Connectors:  
USB 3.0 plug and socket, with locking screws

**USB3.EXT.A2Ax** **Order Code**  
 20 = 20 m cable length  
 30 = 30 m  
 50 = 50 m  
 other lengths up to 100 m on request



### External synchronization cable SK9026

for line scan cameras with USB 3.0 interface.  
 Shielded cable with Hirose plug HR10A, female 6-pin (camera side), and Phoenix 4-pin connector incl. terminal block.

**SK9026.x** **Order Code**  
 cable length 3 / 5 m  
 Other lengths on request



### Combined Synchronization and Power Cable SK9016.1.5-02

For when a power supply in addition to the USB interface is required. Shielded cable, length 1.5 m.

Connectors:  
 Hirose plug HR10A, female 6-pin, (camera side),  
 Lumberg SV50, male 5-pin connector (for supply voltage),  
 Phoenix 6-pin connector incl. terminal block (for synchronization signals)

**SK9016.1.5-02** **Order Code**



### Adapter cable for sync signals CAB-AD Sync-BNC-1

BNC/SMA (3x) to Line Scan Camera Synchronization Cable SK9016/SK9024/SK9026.  
 Shielded cable, length 0.25 m

Connectors:  
 1x Phoenix 4-pin connector  
 3x SMA plug (Line Sync A, Line Sync B, Frame Sync)  
 3x adapter SMA socket (outside threading) to BNC-plug

**CAB-AD Sync-BNC-1** **Order Code**



### Power supply unit PS051003E

Input: 100-240 V AC, 50/60 Hz  
 IEC 60320 C14 coupler (for IEC C13 power cord)

Output: +5 V DC, 2.6 A  
 Cable length: 1.5 m, with Lumberg connector KV50, female 5-pin

**PS051003E** **Order Code**



DE



US



UK

### Power cord PC150...

IEC 60320 C13, 1.5 m, 10 A, 250 V AC

**PC150DE** **Order Code**  
 DE = Europe  
 US = USA, Canada, Japan  
 UK = United Kingdom

## Camera Types: Monochrome

mono chrome CCD

### SK512U3SH

Line scan camera with 35.7 kHz maximum line rate, large dynamic range, anti blooming and integration control.

Pixels, dimensions	512, 14 x 14 µm²
Sensor length	7.17 mm
Max. line frequency	35.7 kHz
Pixel frequencies	30 or 15 MHz
Exposure time	0.01 ... 20 ms
Spectral range	200 ... 1000 nm
Dynamic range	1:2000 (rms)
Special features	Anti blooming, integration control
Pixel data format	8/12 Bit

Lens mount	C-Mount
Camera Casing	AT1

Supply Voltage	USB (500 mA)
Power	2,5 W

mono chrome CCD

### SK1024U3HA

Line scan camera, high speed with 52.63 kHz maximum line rate, spectral range of 200 to 1000 nm.

Pixels, dimensions	1024, 8 x 8 µm²
Sensor length	8.17 mm
Max. line frequency	52.6 kHz
Pixel frequencies	120 or 90 MHz
Exposure time	0.01 ... 20 ms
Spectral range	200 ... 1000 nm
Dynamic range	1:2500 (rms)
Special features	Anti blooming, integration control
Pixel data format	8/12 Bit

Lens mount	C-Mount
Camera Casing	AT1

Supply Voltage	USB (800 mA)
Power	3.3 W

mono chrome CCD

### SK1024U3SH

Line scan camera with 27 kHz maximum line rate, large dynamic range, anti blooming and integration control.

Pixels, dimensions	1024, 14 x 14 µm²
Sensor length	14.30 mm
Max. line frequency	27.0 kHz
Pixel frequencies	30 or 15 MHz
Exposure time	0.01 ... 20 ms
Spectral range	200 ... 1000 nm
Dynamic range	1:2500 (rms)
Special features	Anti blooming, integration control
Pixel data format	8/12 Bit

Lens mount	C-Mount
Camera Casing	AT1

Supply Voltage	USB (500 mA)
Power	2,5 W

mono chrome CCD

### SK2048U3HA

Line scan camera, high speed with 52.63 kHz maximum line rate, spectral range of 200 to 1000 nm.

Pixels, dimensions	2048, 8 x 8 µm²
Sensor length	16.38 mm
Max. line frequency	52.6 kHz
Pixel frequencies	120 or 90 MHz
Exposure time	0.01 ... 20 ms
Spectral range	200 ... 1000 nm
Dynamic range	1:2500 (rms)
Special features	Anti blooming, integration control
Pixel data format	8/12 Bit

Lens mount	C-Mount
Camera Casing	AT1

Supply Voltage	USB (800 mA)
Power	3.3 W

mono chrome CCD

### SK2048U3JR

Line scan camera with high sensitivity and 4.69 kHz maximum line rate.

Pixels, dimensions	2048, 14 x 14 µm²
Sensor length	28.70 mm
Max. line frequency	4.7 kHz
Pixel frequencies	10 or 0 MHz
Exposure time	0.01 ... 20 ms
Spectral range	400 ... 900 nm
Dynamic range	1:1000 (rms)
Special features	Integration control
Pixel data format	8/12 Bit

Lens mount	M40x0.75
Camera Casing	AT2

Supply Voltage	USB (350 mA)
Power	1.8 W

# Line Scan Cameras: USB3.0

## Camera Types: Monochrome *continued*

6

mono  
chrome

CCD



### SK2048U3SH

Line scan camera with large dynamic range and 14.3 kHz maximum line rate, anti blooming and integration control.

Lens mount	M40x0.75
Camera Casing	AT2

Supply Voltage	USB (600 mA)
Power	3 W

Pixels, dimensions	2048, 14 x 14 $\mu\text{m}^2$
Sensor length	28.70 mm
Max. line frequency	14.0 kHz
Pixel frequencies	30 or 15 MHz
Exposure time	0.01 ... 20 ms
Spectral range	200 ... 1000 nm
Dynamic range	1:2500 (rms)
Special features	Anti blooming, integration control
Pixel data format	8/12 Bit

7

mono  
chrome

CCD



### SK5150U3JR

Line scan camera with very high sensitivity, 7.56 kHz maximum line rate.

Lens mount	M40x0.75
Camera Casing	AT2

Supply Voltage	USB (550 mA)
Power	2.8 W

Pixels, dimensions	5148, 7 x 7 $\mu\text{m}^2$
Sensor length	36.00 mm
Max. line frequency	7.6 kHz
Pixel frequencies	40 or 15 MHz
Exposure time	0.133 ... 20 ms
Spectral range	400 ... 900 nm
Dynamic range	1:1000 (rms)
Special features	
Pixel data format	8/12 Bit

8

mono  
chrome

CCD



### SK7456U3TO

Line scan camera with high sensitivity, small pixel size and short sensor length, 5.2 kHz maximum line rate.

Lens mount	M40x0.75
Camera Casing	AT2

Supply Voltage	USB (400 mA)
Power	2.0 W

Pixels, dimensions	7456, 4.7 x 4.7 $\mu\text{m}^2$
Sensor length	35.04 mm
Max. line frequency	5.2 kHz
Pixel frequencies	40 or 15 MHz
Exposure time	0.19 ... 20 ms
Spectral range	400 ... 900 nm
Dynamic range	1:1000 (rms)
Special features	
Pixel data format	8/12 Bit

9

mono  
chrome

CCD



### SK7500U3TO-XL

Line scan camera with 5.2 kHz maximum line rate, high resolution and high sensitivity.

Lens mount	M72x0.75
Camera Casing	CT5

Supply Voltage	USB (600 mA)
Power	3.0 W

Pixels, dimensions	7500, 7 x 7 $\mu\text{m}^2$
Sensor length	52.50 mm
Max. line frequency	5.2 kHz
Pixel frequencies	40 or 15 MHz
Exposure time	0.193 ... 20 ms
Spectral range	400 ... 900 nm
Dynamic range	1:1000 (rms)
Special features	
Pixel data format	8/12 Bit

10

mono  
chrome

CCD



### SK7500U3TF-XB

Line scan camera with 10.1 kHz maximum line rate, high resolution and high sensitivity.

Lens mount	M72x0.75
Camera Casing	ET5

Supply Voltage	USB (920 mA)
Power	4.6 W

Pixels, dimensions	7500, 7 x 7 $\mu\text{m}^2$
Sensor length	52.50 mm
Max. line frequency	10.1 kHz
Pixel frequencies	80 or 40 MHz
Exposure time	0.099 ... 20 ms
Spectral range	400 ... 900 nm
Dynamic range	1:1000 (rms)
Special features	
Pixel data format	8/12 Bit

## Line Scan Cameras: USB3.0

Camera Types: Monochrome *continued*mono  
chrome CCD

## SK8160U3KO-LB

High resolution line scan camera with 11.9 kHz maximum line rate, anti blooming and integration control.



Lens mount	M45x0.75
Camera Casing	AT3L

Supply Voltage	USB (980 mA)
Power	4.9 W

Pixels, dimensions	8160, 5 x 5 $\mu\text{m}^2$
Sensor length	40.80 mm
Max. line frequency	11.9 kHz
Pixel frequencies	100 or 30 MHz
Exposure time	0.01 ... 20 ms
Spectral range	350 ... 900 nm
Dynamic range	1:2000 (rms)
Special features	Anti blooming, integration control
Pixel data format	8/12 Bit

11

## Camera Types: Monochrome, CMOS, for spectrophotometry

mono  
chrome CMOS RECT  
ANGLE

## SK512U3HU

CMOS line scan camera, spectral range 200 to 1000 nm, 26.3 kHz line rate, rectangular pixel shape, suitable for spectrophotometry.



Lens mount	C-Mount
Camera Casing	AT1

Supply Voltage	USB (350 mA)
Power	1.8 W

Pixels, dimensions	512, 25 x 500 $\mu\text{m}^2$
Sensor length	12.80 mm
Max. line frequency	26.3 kHz
Pixel frequencies	15 or 10 MHz
Exposure time	0.01 ... 20 ms
Spectral range	200 ... 1000 nm
Dynamic range	1:5000 (rms)
Special features	Anti blooming, integration control
Pixel data format	8/12 Bit

12

mono  
chrome CMOS RECT  
ANGLE

## SK1024U3HU

CMOS line scan camera, spectral range 200 to 1000 nm, 13.9 kHz line rate, rectangular pixel shape, suitable for spectrophotometry.



Lens mount	C-Mount
Camera Casing	AT1

Supply Voltage	USB (350 mA)
Power	1.8 W

Pixels, dimensions	1024, 12.5 x 500 $\mu\text{m}^2$
Sensor length	12.80 mm
Max. line frequency	13.9 kHz
Pixel frequencies	15 or 10 MHz
Exposure time	0.01 ... 20 ms
Spectral range	200 ... 1000 nm
Dynamic range	1:5000 (rms)
Special features	Anti blooming, integration control
Pixel data format	8/12 Bit

13

mono  
chrome CMOS RECT  
ANGLE

## SK1024U3HV

CMOS line scan camera, spectral range 200 to 1000 nm, 13.9 kHz line rate, rectangular pixel shape, suitable for spectrophotometry.



Lens mount	M40x0.75
Camera Casing	AT2

Supply Voltage	USB (350 mA)
Power	1.8 W

Pixels, dimensions	1024, 25 x 500 $\mu\text{m}^2$
Sensor length	25.60 mm
Max. line frequency	13.9 kHz
Pixel frequencies	15 MHz
Exposure time	0.01 ... 20 ms
Spectral range	200 ... 1000 nm
Dynamic range	1:5000 (rms)
Special features	Anti blooming, integration control
Pixel data format	8/12 Bit

14

mono  
chrome CMOS RECT  
ANGLE

## SK2048U3HU

CMOS line scan camera, spectral range 200 to 1000 nm, 7.14 kHz line rate, rectangular pixel shape, suitable for spectrophotometry.



Lens mount	M40x0.75
Camera Casing	AT2

Supply Voltage	USB (350 mA)
Power	1.8 W

Pixels, dimensions	2048, 12.5 x 500 $\mu\text{m}^2$
Sensor length	25.60 mm
Max. line frequency	7.1 kHz
Pixel frequencies	15 or 10 MHz
Exposure time	0.01 ... 20 ms
Spectral range	200 ... 1000 nm
Dynamic range	1:5000 (rms)
Special features	Anti blooming, integration control
Pixel data format	8/12 Bit

15

# Line Scan Cameras: USB3.0

Camera Types: Monochrome, CMOS, for spectrophotometry **continued**

16

mono chrome CMOS RECT ANGLE



## SK2048U3HW

CMOS line scan camera, spectral range 200 to 1000 nm, 6.89 kHz line rate, rectangular pixel shape, suitable for spectrophotometry.

Lens mount	M40x0.75
Camera Casing	AT2

Supply Voltage	USB (350 mA)
Power	1.8 W

Pixels, dimensions	2048, 14 x 200 $\mu\text{m}^2$
Sensor length	28.67 mm
Max. line frequency	6.9 kHz
Pixel frequencies	15 or 10 MHz
Exposure time	0.01 ... 20 ms
Spectral range	200 ... 1000 nm
Dynamic range	1:2000 (rms)
Special features	Anti blooming, integration control
Pixel data format	8/12 Bit

17

mono chrome CMOS RECT ANGLE



## SK4096U3HW

CMOS line scan camera, spectral range 200 to 1000 nm, 2.38 kHz line rate, rectangular pixel shape, suitable for spectrophotometry.

Lens mount	M40x0.75
Camera Casing	AT2

Supply Voltage	USB (350 mA)
Power	1.8 W

Pixels, dimensions	4096, 7 x 200 $\mu\text{m}^2$
Sensor length	28.67 mm
Max. line frequency	2.4 kHz
Pixel frequencies	10 MHz
Exposure time	0.01 ... 20 ms
Spectral range	200 ... 1000 nm
Dynamic range	1:5000 (rms)
Special features	Anti blooming, integration control
Pixel data format	8/12 Bit

Camera Types: Color

1

RGB CCD



## SK6288U3KOC

Color line scan camera (Triple-Line) with 3 x 2096 RGB pixels, 9.28 kHz maximum line rate, integration control.

Lens mount	M40x0.75
Camera Casing	AT2

Supply Voltage	USB (600 mA)
Power	3.0 W

Pixels, dimensions	2096 x 3, 14 x 14 $\mu\text{m}^2$
Sensor length	29.30 mm
Max. line frequency	9.3 kHz
Pixel frequencies	60 or 30 MHz
Exposure time	0.01 ... 20 ms
Spectral range	400 ... 700 nm
Dynamic range	1:2500 (rms)
Special features	Integration control
Pixel data format	8/12 Bit
Line spacing, color sequence	112 $\mu\text{m}$ , BGR

2

RGB CCD



## SK8100U3JRC

Color line scan camera (Triple-Line) with 3 x 2700 RGB pixels, 2.86 kHz maximum line rate, integration control.

Lens mount	M40x0.75
Camera Casing	AT2

Supply Voltage	USB (500 mA)
Power	2.5 W

Pixels, dimensions	2700 x 3, 8 x 8 $\mu\text{m}^2$
Sensor length	21.60 mm
Max. line frequency	2.9 kHz
Pixel frequencies	24 or 15 MHz
Exposure time	0.01 ... 20 ms
Spectral range	400 ... 700 nm
Dynamic range	1:2000 (rms)
Special features	Integration control
Pixel data format	8/12 Bit
Line spacing, color sequence	64 $\mu\text{m}$ , RGB

3

RGB CCD



## SK10944U3JRC

Color line scan camera (Triple-Line) with 3 x 3648 RGB pixels, 2.14 kHz maximum line rate, integration control.

Lens mount	M40x0.75
Camera Casing	AT2

Supply Voltage	USB (500 mA)
Power	2.5 W

Pixels, dimensions	3648 x 3, 8 x 8 $\mu\text{m}^2$
Sensor length	29.20 mm
Max. line frequency	2.1 kHz
Pixel frequencies	24 or 15 MHz
Exposure time	0.01 ... 20 ms
Spectral range	400 ... 700 nm
Dynamic range	1:2000 (rms)
Special features	Integration control
Pixel data format	8/12 Bit
Line spacing, color sequence	64 $\mu\text{m}$ , RGB

## Line Scan Cameras: USB3.0

Camera Types: Color *continued*

RGB CCD

4



Lens mount	M45x0.75
Camera Casing	AT3L

## SK12240U3KOC-LB

Color line scan camera (Triple-Line) with 3 x 4080 RGB pixels, 4.8 kHz maximum line rate, anti blooming and integration control.

Supply Voltage	5V DC (1.1A)
Power	5.5 W

Pixels, dimensions	4080 x 3, 10 x 10 $\mu\text{m}^2$
Sensor length	40.80 mm
Max. line frequency	4.8 kHz
Pixel frequencies	60 or 30 MHz
Exposure time	0.01 ... 20 ms
Spectral range	400 ... 700 nm
Dynamic range	1:2500 (rms)
Special features	Anti blooming, integration control
Pixel data format	8/12 Bit
Line spacing, color sequence	90 $\mu\text{m}$ , GRB

RGB CMOS

5



Lens mount	M45x0.75
Camera Casing	AT3

## SK16080U3JRC-L

Color line scan camera (Triple-Line) with 3 x 5360 RGB pixels 24 MHz pixel frequency, integration control

Supply Voltage	USB (500 mA)
Power	2.5 W

Pixels, dimensions	5360 x 3, 8 x 8 $\mu\text{m}^2$
Sensor length	42.90 mm
Max. line frequency	1.5 kHz
Pixel frequencies	24 or 15 MHz
Exposure time	0.01 ... 20 ms
Spectral range	400 ... 700 nm
Dynamic range	1:2000 (rms)
Special features	Integration control
Pixel data format	8/12 Bit
Line spacing, color sequence	64 $\mu\text{m}$ , RGB

RGB CMOS

6



Lens mount	M40x0.75
Camera Casing	AT2

## SK16200U3TOC

Color line scan camera (Triple-Line) with 3 x 5400 RGB pixels, 8,7 kHz maximum line rate.

Supply Voltage	USB (800 mA)
Power	4.0 W

Pixels, dimensions	5400 x 3, 7 x 7 $\mu\text{m}^2$
Sensor length	37.80 mm
Max. line frequency	8.7 kHz
Pixel frequencies	150 or 75 MHz
Exposure time	0.115 ... 20 ms
Spectral range	350 ... 700 nm
Dynamic range	1:1250 (rms)
Special features	
Pixel data format	3*8 Bit
Line spacing, color sequence	28 $\mu\text{m}$ , RGB

RGB CMOS

7



Lens mount	M40x0.75
Camera Casing	AT2

## SK22368U3TOC

Color line scan camera (Triple-Line) with 3 x 7456 RGB pixels, 6.41 kHz maximum line rate, small pixel size and short sensor length.

Supply Voltage	USB (800 mA)
Power	4.0 W

Pixels, dimensions	7456 x 3, 4.7 x 4.7 $\mu\text{m}^2$
Sensor length	35.04 mm
Max. line frequency	6.4 kHz
Pixel frequencies	150 or 75 MHz
Exposure time	0.156 ... 20 ms
Spectral range	350 ... 700 nm
Dynamic range	1:1000 (rms)
Special features	
Pixel data format	3*8 Bit
Line spacing, color sequence	18.8 $\mu\text{m}$ , RGB

RGB CMOS

8

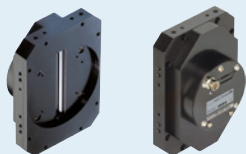

Lens mount	Ø80 H8
Camera Casing	FT7

## SK22800U3JRC-XC

Color line scan camera (Triple-Line) with 3 x 7600 RGB pixels, 6.17 kHz maximum line rate, high resolution.

Supply Voltage	5V DC (1.5A)
Power	7.3 W

Pixels, dimensions	7600 x 3, 9.3 x 9.3 $\mu\text{m}^2$
Sensor length	70.87 mm
Max. line frequency	6.2 kHz
Pixel frequencies	150 or 60 MHz
Exposure time	0.162 ... 20 ms
Spectral range	350 ... 680 nm
Dynamic range	1:1000 (rms)
Special features	
Pixel data format	3*8 Bit
Line spacing, color sequence	9.3 $\mu\text{m}$ , BGR



# Interface Camera Link



## Introduction

Camera Link is a standardized interface for industrial image acquisition and is designed for fast data transmission.

For controlling a Schäfter+Kirchhoff line scan camera, any third party grabber board is suitable when in the base configuration it complies with the Camera Link standard. The camera and grabber board are connected using a standard cable with MDR26 mini-ribbon plug connectors.

Use the software development kits provided from the grabber board manufacturers when developing customized applications. On request, Schäfter+Kirchhoff can provide the Camera Link configuration file of the specified camera type matched to the grabber. The basic camera parameters can also be configured with the SkCLconfig tool from Schäfter+Kirchhoff. This tool can be downloaded from the support area of the Schäfter+Kirchhoff homepage.

Schäfter+Kirchhoff provides a wide range of accessories for the line scan cameras with Camera Link interface, including focus adapters, extension rings, lenses and mounting brackets for industrial use.



## Accessories: Camera Link

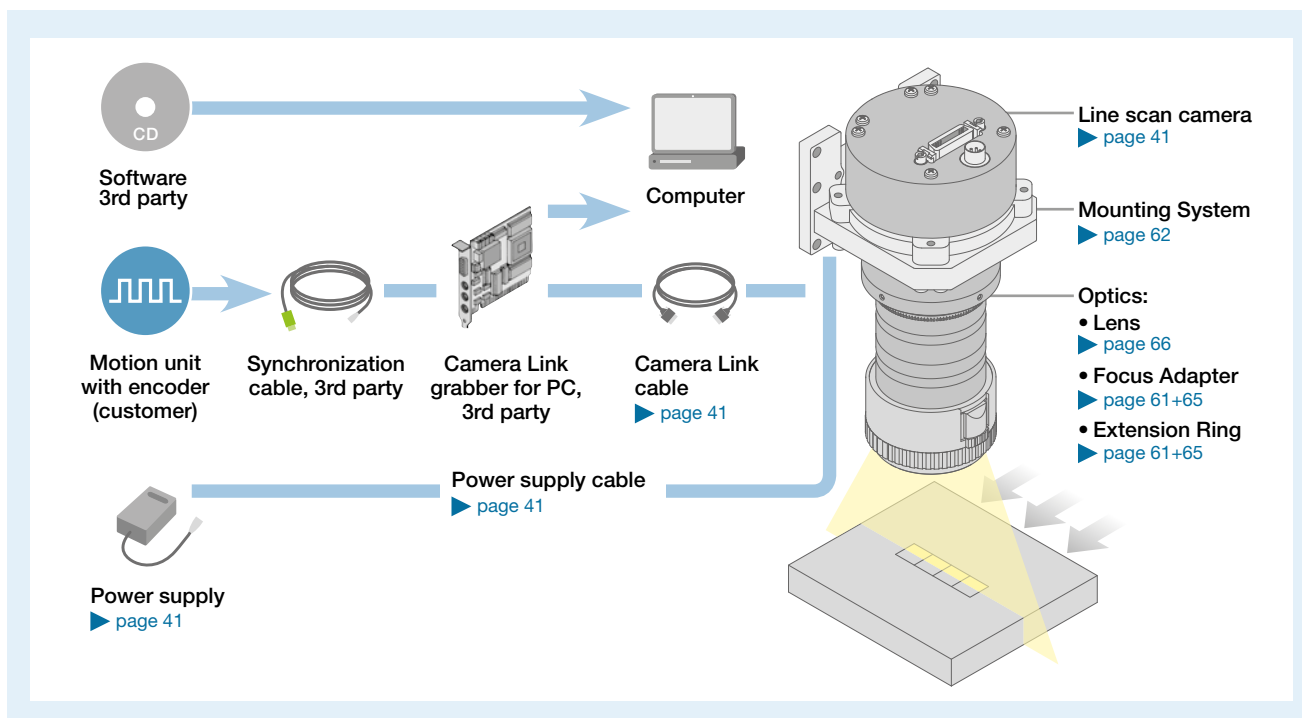

## Connections and I/O Signals

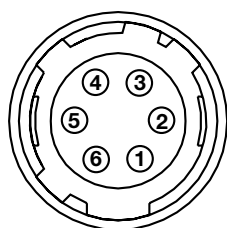

**1 Power Supply**  
Power: 2.5 W  
Socket: Hirose series 10A, male 6-pin

Pin	Signal	Pin	Signal
1	+15 V	4	+5 V
2	+15 V	5	GND
3	+5 V	6	GND

**2 Camera Link Connector**  
Miniature Delta Ribbon,  
female 26-pin (MDR-26)

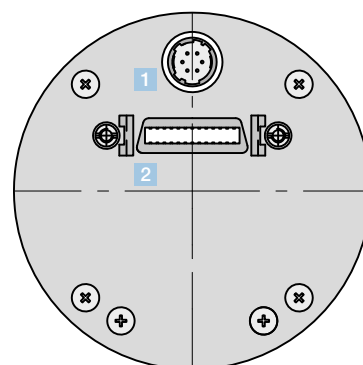



# Overview: Camera Link

## Monochrome Cameras

Pos.	Order Code	Pixels	Active Length [mm]	Pixel Size [µm]	Max. Pixel Frequency [MHz]	Max. Line Frequency [kHz]	Dynamic Range (RMS)	Casing	Lens Mount	Sensor Technology	Anti-Blooming	Integration Control
1	SK512CSH	512	7.17	14 x 14	30	35.7	1:2000	AC1	C-Mount	CCD	x	x
2	SK1024CSH	1024	14.30	14 x 14	30	27.0	1:2000	AC1	C-Mount	CCD	x	x
3	SK2048CHA	2048	16.38	8 x 8	120	52.6	1:2500	AC1	C-Mount	CCD	x	x
4	SK2048CJR	2048	28.70	14 x 14	10	4.7	1:625	AC2	M40x0.75	CCD	-	x
5	SK2048CSH	2048	28.70	14 x 14	30	14.0	1:2000	AC2	M40x0.75	CCD	x	x
6	SK5150CJR	5148	36.00	7 x 7	40	7.6	1:500	AC2	M40x0.75	CCD	-	-
7	SK7456CTO	7456	35.04	4.7 x 4.7	40	5.2	1:1000	AC2	M40x0.75	CCD	-	-
8	SK7500CTO-XL	7500	52.50	7 x 7	40	5.2	1:750	CC5	M72x0.75	CCD	-	-
9	SK7500CTF-XB	7500	52.50	7 x 7	80	10.1	1:1000	EC5	M72x0.75	CCD	-	-
10	SK8160CKO-LB	8160	40.80	5 x 5	100	11.9	1:2500	AC3L	M45x0.75	CCD	x	x

## Color Cameras

Pos.	Order Code	Pixels	Active Length [mm]	Pixel Size [µm]	Max. Pixel Frequency [MHz]	Max. Line Frequency [kHz]	Dynamic Range (RMS)	Casing	Lens Mount	Sensor Technology	Anti Blooming	Integration Control
1	SK6288CKOC	2096 x 3	29.30	14 x 14	60	9.3	1:2500	AC2	M40x0.75	CCD	-	x
2	SK12240CKOC-LB	4080 x 3	40.80	10 x 10	60	4.8	1:2500	AC3L	M45x0.75	CCD	x	x
3	SK22368CTOC	7456 x 3	35.04	4.7 x 4.7	150	6.4	1:1000	AC2	M40x0.75	CCD	-	-
4	SK22800CJRC-XC	7600 x 3	70.87	9.3 x 9.3	150	6.2	1:1000	FC7	Ø80 H8	CCD	-	-

Casings and dimensions ► page 50

Detailed data sheets, up-to-date technical information, technical drawings including step files, accessories, extensive technotes section and FAQs: [www.sukhamburg.com](http://www.sukhamburg.com)



## Electrical Installation: Connection Cables and Power Supply



### Control cable SK9018...

for line scan cameras with Camera Link interface.  
26-pin shielded cable, both ends with mini-ribbon connector (male 26-pin)

### SK9018.xMM Order Code

MM = connector both ends male  
cable length 3 / 5 m or length of your choice, max. 10m



### Power cable SK9015.x

for GigE Vision™, Camera Link and externally powered USB 3 line scan cameras.  
Shielded cable with Hirose plug HR10A, female 6-pin (camera side), and Lumberg SV60, male 6-pin connector (power supply unit side).

### SK9015.x Order Code

cable length 0.2 / 1.5 m

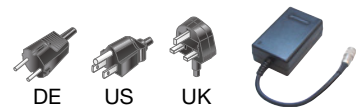

### Power supply unit PS051515

Input: 100-240 V AC, 0.8 A, 50/60 Hz  
IEC 60320 C14 coupler (for IEC C13 power cord)  
Output: +5 V DC, 2.5 A / +15 V DC, 0.5 A / -15 V DC, 0.3 A

Cable length: 1 m, with Lumberg connector KV60, female 6-pin  
PS051515 Order Code

Power cord IEC 60320 C13, 1.5 m, 10 A, 250 V AC

PC150DE Order Code  
DE = Europe  
US = USA, Canada, Japan  
UK = United Kingdom

## Line Scan Cameras: Camera Link

Camera Types: Monochrome

mono  
chrome CCD

1



Lens mount	C-Mount
Camera Casing	AC1

## SK512CSH

Line scan camera with 35,7 kHz maximum line rate, large dynamic range, anti blooming and integration control.

Supply Voltage	+5V, +15V
Power	2,5 W

Pixels, dimension	512, 14 x 14 $\mu\text{m}^2$
Sensor length	7.17 mm
Max. line frequency	35.7 kHz
Pixel frequencies	30 or 20 MHz
Exposure time	0.01 ... 20 ms
Spectral range	200 ... 1000 nm
Dynamic range	1:2000 (rms)
Special features	Anti blooming, integration control
Pixel data format	8/12 Bit

mono  
chrome CCD

2



Lens mount	C-Mount
Camera Casing	AC1

## SK1024CSH

Line scan camera with 27 kHz maximum line rate, large dynamic range, anti blooming and integration control.

Supply Voltage	+5V, +15V
Power	2,5 W

Pixels, dimensions	1024, 14 x 14 $\mu\text{m}^2$
Sensor length	14.30 mm
Max. line frequency	27.0 kHz
Pixel frequencies	30 or 20 MHz
Exposure time	0.01 ... 20 ms
Spectral range	200 ... 1000 nm
Dynamic range	1:2000 (rms)
Special features	Anti blooming, integration control
Pixel data format	8/12 Bit

mono  
chrome CCD

3



Lens mount	C-Mount
Camera Casing	AC1

## SK2048CHA

Line scan camera, high speed with 52.63 kHz maximum line rate, spectral range of 200 to 1000 nm.

Supply Voltage	+5V, +15V
Power	3.6 W

Pixels, dimension	2048, 8 x 8 $\mu\text{m}^2$
Sensor length	16.38 mm
Max. line frequency	52.6 kHz
Pixel frequencies	120 or 60 MHz
Exposure time	0.01 ... 20 ms
Spectral range	200 ... 1000 nm
Dynamic range	1:2500 (rms)
Special features	Anti blooming, integration control
Pixel data format	8/12 Bit

mono  
chrome CCD

4



Lens mount	M40x0.75
Camera Casing	AC2

## SK2048CJR

Line scan camera with high sensitivity and 4.73 kHz maximum line rate.

Supply Voltage	+5V, +15V
Power	2.1 W

Pixels, dimensions	2048, 14 x 14 $\mu\text{m}^2$
Sensor length	28.70 mm
Max. line frequency	4.7 kHz
Pixel frequencies	10 MHz
Exposure time	0.003 ... 20 ms
Spectral range	400 ... 900 nm
Dynamic range	1:625 (rms)
Special features	Integration control
Pixel data format	8/12 Bit

mono  
chrome CCD

5



Lens mount	M40x0.75
Camera Casing	AC2

## SK2048CSH

Line scan camera with large dynamic range and 14.3 kHz maximum line rate, anti blooming and integration control.

Supply Voltage	+5V, +15V
Power	2,9 W

Pixels, dimensions	2048, 14 x 14 $\mu\text{m}^2$
Sensor length	28.70 mm
Max. line frequency	14.0 kHz
Pixel frequencies	30 or 20 MHz
Exposure time	0.01 ... 20 ms
Spectral range	200 ... 1000 nm
Dynamic range	1:2000 (rms)
Special features	Anti blooming, integration control
Pixel data format	8/12 Bit

# Line Scan Cameras: Camera Link

## Camera Types: Monochrome *continued*

6

mono  
chrome

CCD



### SK5150CJR

Line scan camera with very high sensitivity, 7.56 kHz maximum line rate.

Lens mount	M40x0.75
Camera Casing	AC2

Supply Voltage	+5V, +15V
Power	3.1 W

Pixels, dimensions	5148, 7 x 7 $\mu\text{m}^2$
Sensor length	36.00 mm
Max. line frequency	7.6 kHz
Pixel frequencies	40 MHz
Exposure time	0.133 ... 20 ms
Spectral range	400 ... 900 nm
Dynamic range	1:500 (rms)
Special features	
Pixel data format	8/12 Bit

7

mono  
chrome

CCD



### SK7456CTO

Line scan camera with high sensitivity, small pixel size and short sensor length, 5.2 kHz maximum line rate.

Lens mount	M40x0.75
Camera Casing	AC2

Supply Voltage	+5V, +15V
Power	2.2 W

Pixels, dimensions	7456, 4.7 x 4.7 $\mu\text{m}^2$
Sensor length	35.04 mm
Max. line frequency	5.2 kHz
Pixel frequencies	40 or 20 MHz
Exposure time	0.19 ... 20 ms
Spectral range	400 ... 900 nm
Dynamic range	1:1000 (rms)
Special features	
Pixel data format	8/12 Bit

8

mono  
chrome

CCD

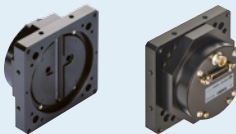

### SK7500CTO-XL

Line scan camera with 5.2 kHz maximum line rate, high resolution and high sensitivity.

Lens mount	M72x0.75
Camera Casing	CC5

Supply Voltage	+5V, +15V
Power	3.0 W

Pixels, dimensions	7500, 7 x 7 $\mu\text{m}^2$
Sensor length	52.50 mm
Max. line frequency	5.2 kHz
Pixel frequencies	40 MHz
Exposure time	0.192 ... 20 ms
Spectral range	400 ... 900 nm
Dynamic range	1:750 (rms)
Special features	
Pixel data format	8/12 Bit

9

mono  
chrome

CCD

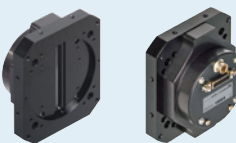

### SK7500CTF-XB

Line scan camera with 10.1 kHz maximum line rate, high resolution and high sensitivity.

Lens mount	M72x0.75
Camera Casing	EC5

Supply Voltage	+5V, +15V
Power	4.6 W

Pixels, dimensions	7500, 7 x 7 $\mu\text{m}^2$
Sensor length	52.50 mm
Max. line frequency	10.1 kHz
Pixel frequencies	80 or 40 MHz
Exposure time	0.121 ... 20 ms
Spectral range	400 ... 900 nm
Dynamic range	1:1000 (rms)
Special features	
Pixel data format	8/12 Bit

10

mono  
chrome

CCD



### SK8160CKO-LB

High resolution line scan camera with 11.9 kHz maximum line rate, anti blooming and integration control.

Lens mount	M45x0.75
Camera Casing	AC3L

Supply Voltage	+5V, +15V
Power	6.6 W

Pixels, dimensions	8160, 5 x 5 $\mu\text{m}^2$
Sensor length	40.80 mm
Max. line frequency	11.9 kHz
Pixel frequencies	100 MHz
Exposure time	0.01 ... 20 ms
Spectral range	350 ... 900 nm
Dynamic range	1:2500 (rms)
Special features	Anti blooming, integration control
Pixel data format	2*8/12 Bit

## Line Scan Cameras: Camera Link

Camera Types: Color



1



Lens mount	M40x0.75
Camera Casing	AC2

## SK6288CKOC

Color line scan camera (Triple-Line) with 3 x 2096 RGB pixels, 9.28 kHz maximum line rate, integration control.

Supply Voltage	+5V, +15V
Power	3.3 W

Pixels, dimensions	2096 x 3, 14 x 14 $\mu\text{m}^2$
Sensor length	29.30 mm
Max. line frequency	9.3 kHz
Pixel frequencies	60 MHz
Exposure time	0.01 ... 20 ms
Spectral range	400 ... 700 nm
Dynamic range	1:2500 (rms)
Special features	Integration control
Pixel data format	8/12 Bit
Line spacing, color sequence	112 $\mu\text{m}$ , BGR



2



Lens mount	M45x0.75
Camera Casing	AC3L

## SK12240CKOC-LB

Color line scan camera (Triple-Line) with 3 x 4080 RGB pixels, 4.8 kHz maximum line rate, anti blooming, integration control.

Supply Voltage	+5V, +15V
Power	5.8 W

Pixels, dimensions	4080 x 3, 10 x 10 $\mu\text{m}^2$
Sensor length	40.80 mm
Max. line frequency	4.8 kHz
Pixel frequencies	60 or 30 MHz
Exposure time	0.01 ... 20 ms
Spectral range	400 ... 700 nm
Dynamic range	1:2500 (rms)
Special features	Anti blooming, integration control
Pixel data format	8/12 Bit
Line spacing, color sequence	90 $\mu\text{m}$ , GRB



3



Lens mount	M40x0.75
Camera Casing	AC2

## SK22368CTOC

Color line scan camera (Triple-Line) with 3 x 7456 RGB pixels, 6.41 kHz maximum line rate, small pixel size and short sensor length.

Supply Voltage	+5V, +15V
Power	4.3 W

Pixels, dimensions	7456 x 3, 4.7 x 4.7 $\mu\text{m}^2$
Sensor length	35.04 mm
Max. line frequency	6.4 kHz
Pixel frequencies	150 or 60 MHz
Exposure time	0.156 ... 20 ms
Spectral range	350 ... 700 nm
Dynamic range	1:1000 (rms)
Special features	
Pixel data format	3*8 Bit
Line spacing, color sequence	18.8 $\mu\text{m}$ , RGB



4

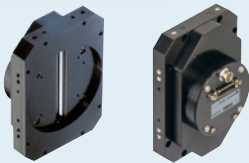

Lens mount	Ø80 H8
Camera Casing	FC7

## SK22800CJRC-XC

Color line scan camera (Triple-Line) with 3 x 7600 RGB pixels, 6.17 kHz maximum line rate, high resolution.

Supply Voltage	+5V, +15V
Power	7.6 W

Pixels, dimensions	7600 x 3, 9.3 x 9.3 $\mu\text{m}^2$
Sensor length	70.87 mm
Max. line frequency	6.2 kHz
Pixel frequencies	150 or 60 MHz
Exposure time	0.162 ... 20 ms
Spectral range	350 ... 680 nm
Dynamic range	1:1000 (rms)
Special features	
Pixel data format	3*8 Bit
Line spacing, color sequence	9.3 $\mu\text{m}$ , BGR

Detailed data sheets, up-to-date technical information, technical drawings including step files, accessories, extensive technotes section and FAQs:  
[www.sukhamburg.com](http://www.sukhamburg.com)







# Gigabit Ethernet / GigE Vision™ Interface

## M72x0.75

### CG5

- SK7500GTO-4XL
- SK8160GKO-4XL
- SK12240GKOC-4XL

- SK7500VTO-4XL
- SK8160VKO-4XL
- SK12240VKOC-4XL

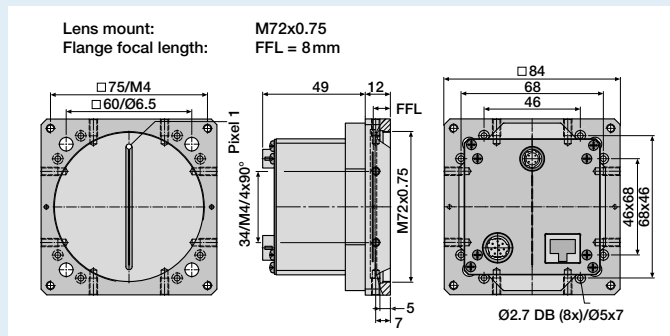
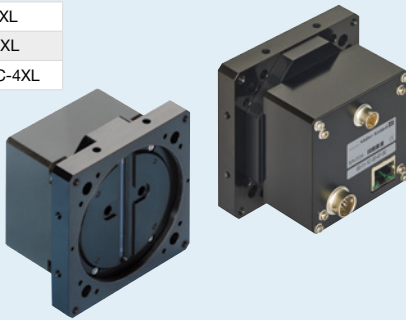

### EG5

- SK7500GTF-4XB

- SK7500VTF-4XB

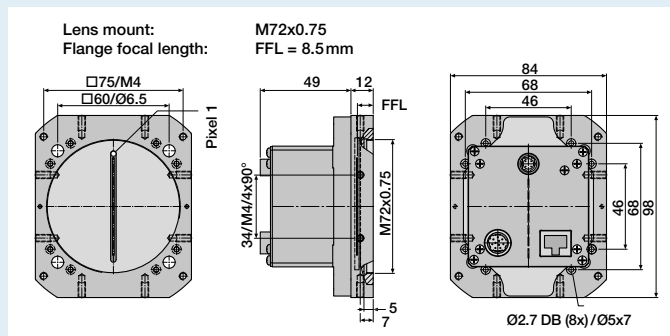
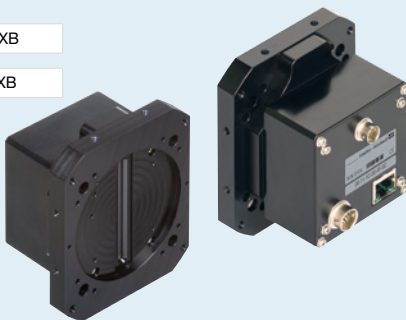

### FG7

- SK22800GJRC-4XC

- SK22800VJRC-4XC

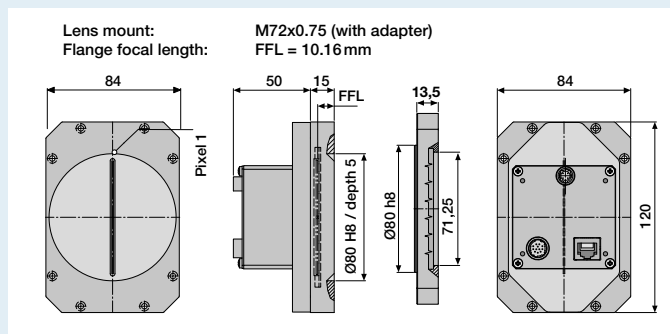
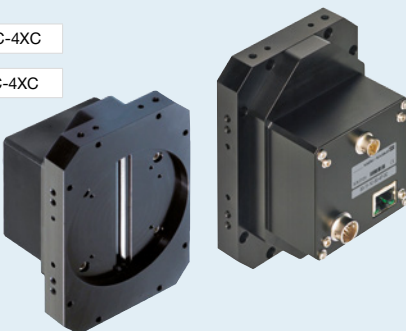

Detailed data sheets, up-to-date technical information, technical drawings including step files, accessories, extensive technotes section and FAQs:  
[www.sukhamburg.com](http://www.sukhamburg.com)



# USB3.0 Interface

## C-Mount

### AT1

- SK512U3SH
- SK512U3HU
- SK1024U3HA
- SK1024U3HU
- SK1024U3SH
- SK2048U3HA

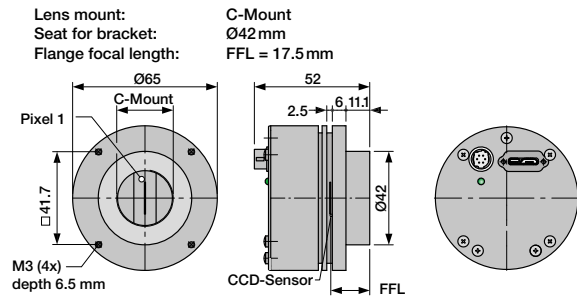

## M40x0.75

### AT2

- SK1024U3HV
- SK2048U3HU
- SK2048U3HW
- SK2048U3JR
- SK2048U3SH
- SK4096U3HW
- SK5150U3JR
- SK7456U3TO
- SK6288U3KOC
- SK8100U3JRC
- SK10944U3JRC
- SK16200U3TOC
- SK22368U3TOC

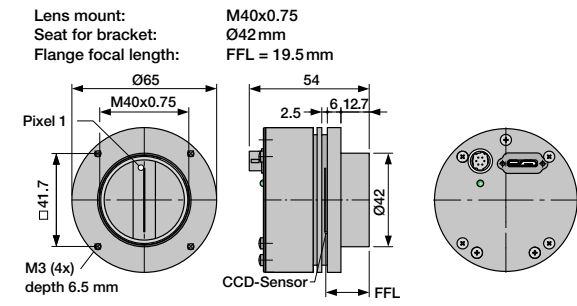

## M45x0.75

### AT3

- SK16080U3JRC-L

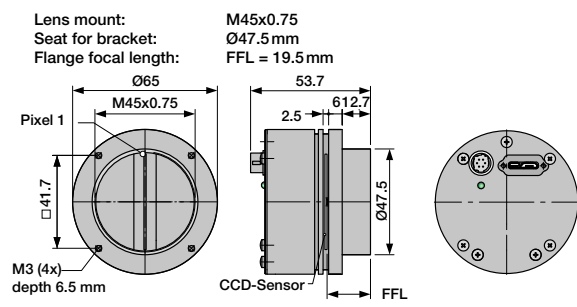

### AT3L

- SK8160U3KO-LB
- SK12240U3KOC-LB

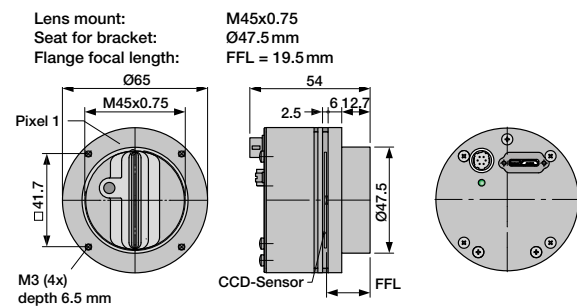



# USB3.0 Interface

M72x0.75

CT5

SK7500U3TO-XL

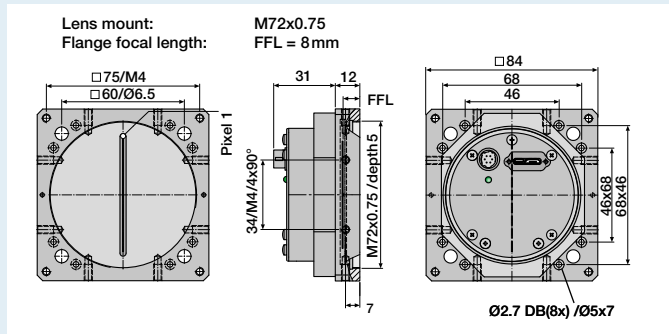
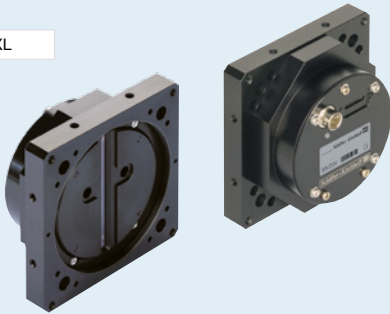

ET5

SK7500U3TF-XB

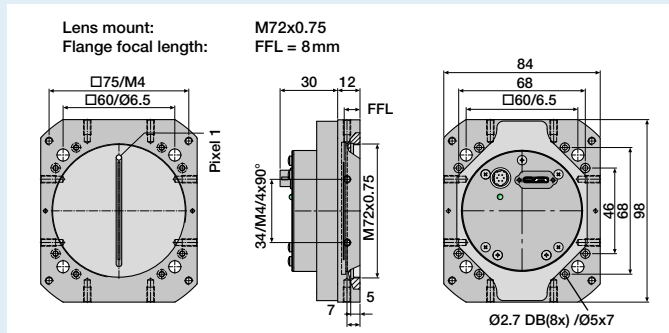
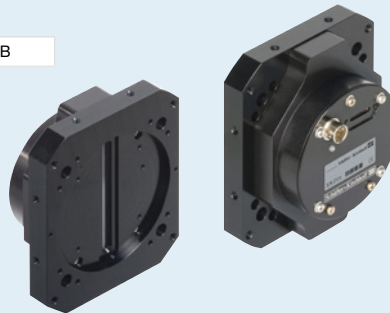

FT7

SK22800U3JRC-XC

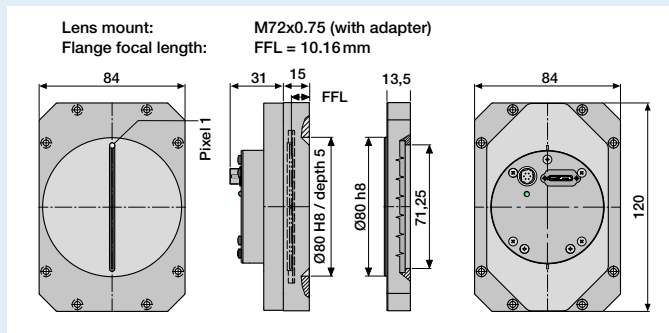
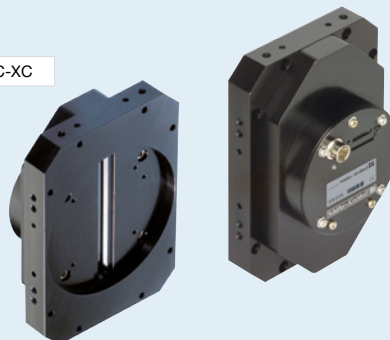

# Camera Link Interface

## C-Mount

### AC1

- SK512CSH
- SK1024CSH
- SK2048CHA

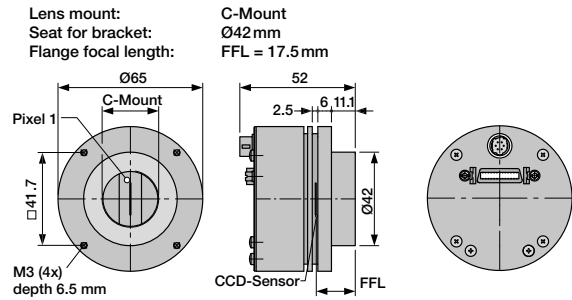

## M40x0.75

### AC2

- SK2048CSH
- SK2048CJR
- SK5150CJR
- SK7456CTO
- SK6288CKOC
- SK22368CTOC

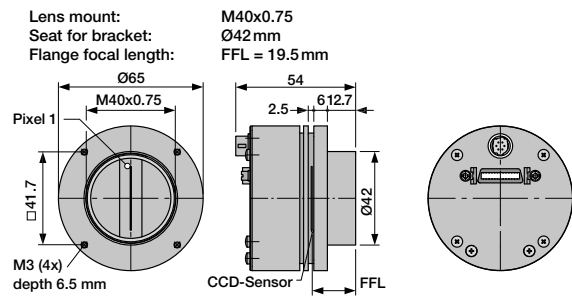

## M45x0.75

### AC3L

- SK8160CKO-LB
- SK12240CKOC-LB

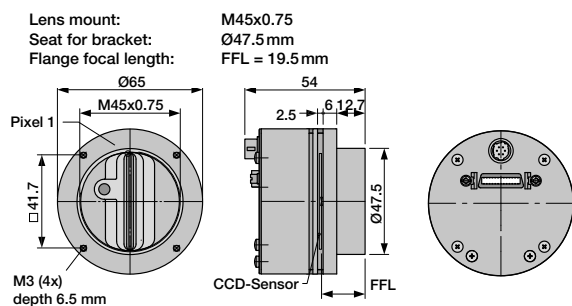

# Camera Link Interface

## M72x0.75

### CC5

SK7500CTO-XL

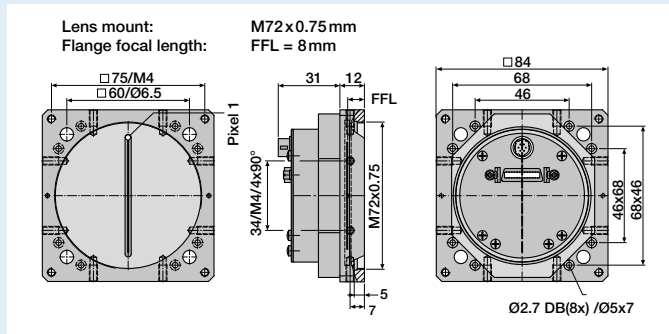
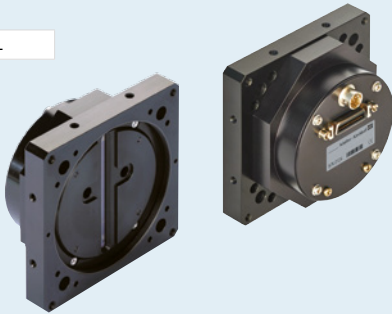

### EC5

SK7500CTF-XB

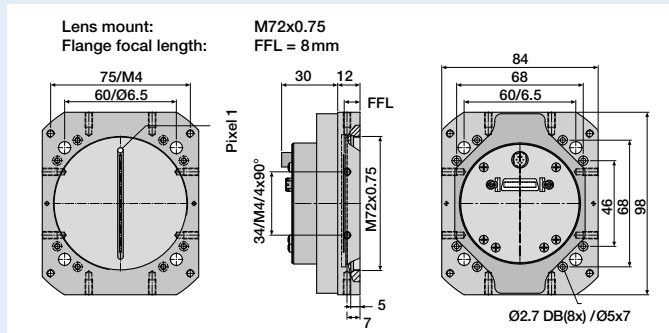

### FC7

SK22800CJRC-XC

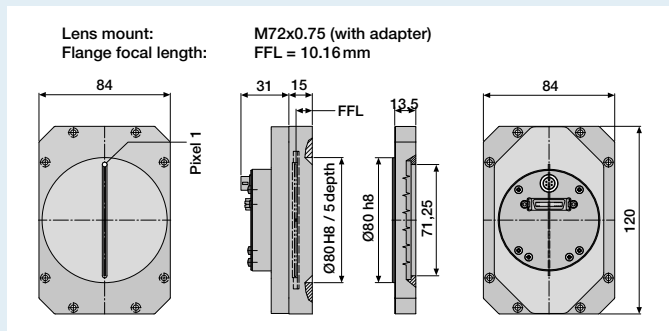
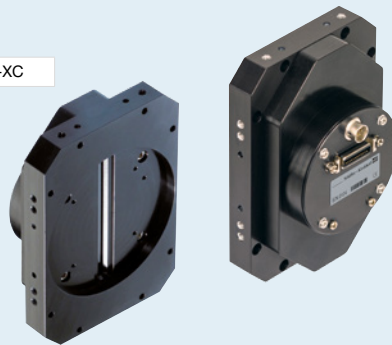

# Software

**Software for Line Scan  
Camera Systems**

## ■ Software for Line Scan Cameras

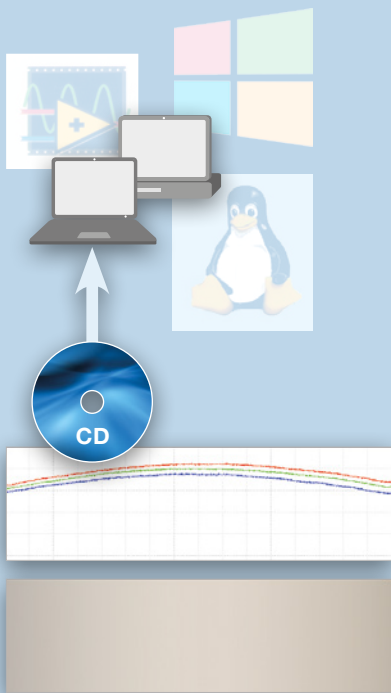

SKLineScan Program —————→ 54

Software Development Kit (SDK) —————→ 57

Overview: Software Products —————→ 57

# Software for Line Scan Cameras

## SkLineScan program and Software Development Kit (SDK)

- The software is available for line scan cameras with a GigE or USB 3.0 interface
- Operation program SkLineScan for setup and simple scanning tasks
- SDK with API and class library for the development of customized application software
- Examples in C/C++ can be used as templates for developing custom programs
- VI Library for LabVIEW
- Supported operating systems are 32 or 64-bit Windows 7, 8.1, 10, and Linux kernel 3.13+

```
int CCameraInit::Camera(int CamID, DWORD IPAddr, DWORD Subnet)
{
    if (SK_GETDEVICES() < CamID + 1)
        return SK_RESULT_DEVICE_ERROR;
    if (IPAddr != 0)
    {
        // set IP address
        if (SK_SETIPADDRESS(CamID, IPAddr, Subnet)
            != SK_RESULT_OK)
            return SK_RESULT_NETWORK_ERROR;
    }
    int result = 1;
    result = SK_INITCAMERA(CamID);
    if (result != SK_RESULT_OK)
        return SK_RESULT_DEVICE_ERROR;
}
}
```

### SkLineScan program

The Schäfter+Kirchhoff SkLineScan program is designed for the start-up and control of their line scan cameras. All functions of the connected cameras can be checked. The user can adjust the total optical system of camera, lens and illumination by using the real-time display of the line signal **A**.

The operating parameters of the camera can be changed interactively during signal acquisition.

Each individual pixel of the line signal can be displayed by using the zoom or scroll functions and signal images can be saved.

The program also enables a two-dimensional area scan of a surface to be acquired by accumulating repetitive line scans from the line scan camera.

The SkLineScan program is free for downloading from the support area of the Schäfter+Kirchhoff homepage.

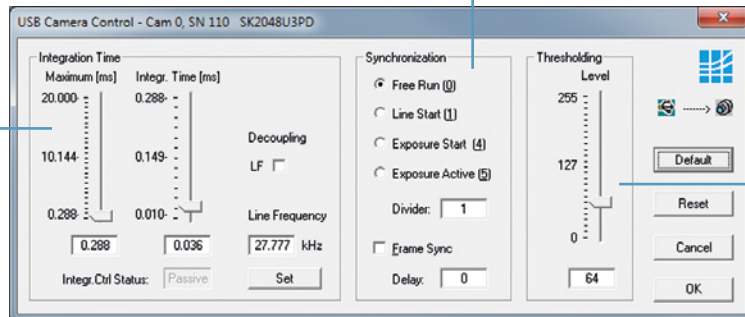
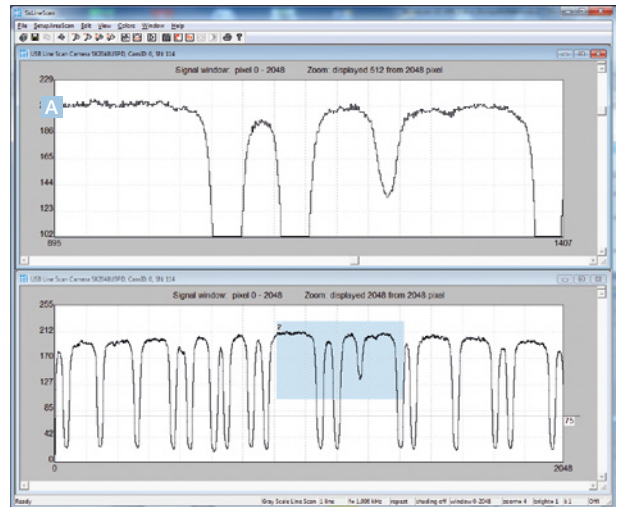

Control of the camera integration time and setting of line frequency.   
 Decoupling of line frequency and integration time.

Selection of synchronization mode.   
 Adjustment of the trigger clock divider.

Adjustment of the intensity level for binarization of the line signal in threshold operation mode.

### A color area scan using the SkLineScan program

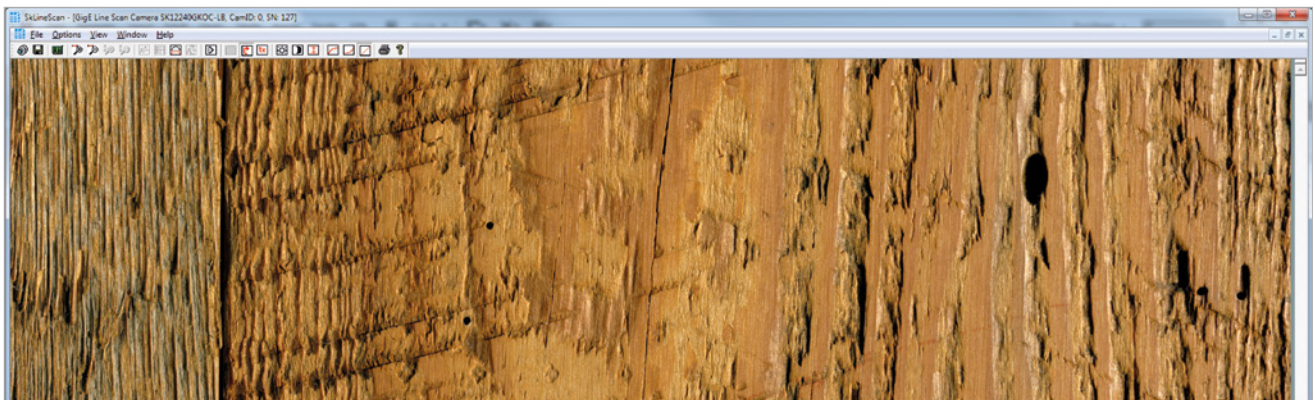

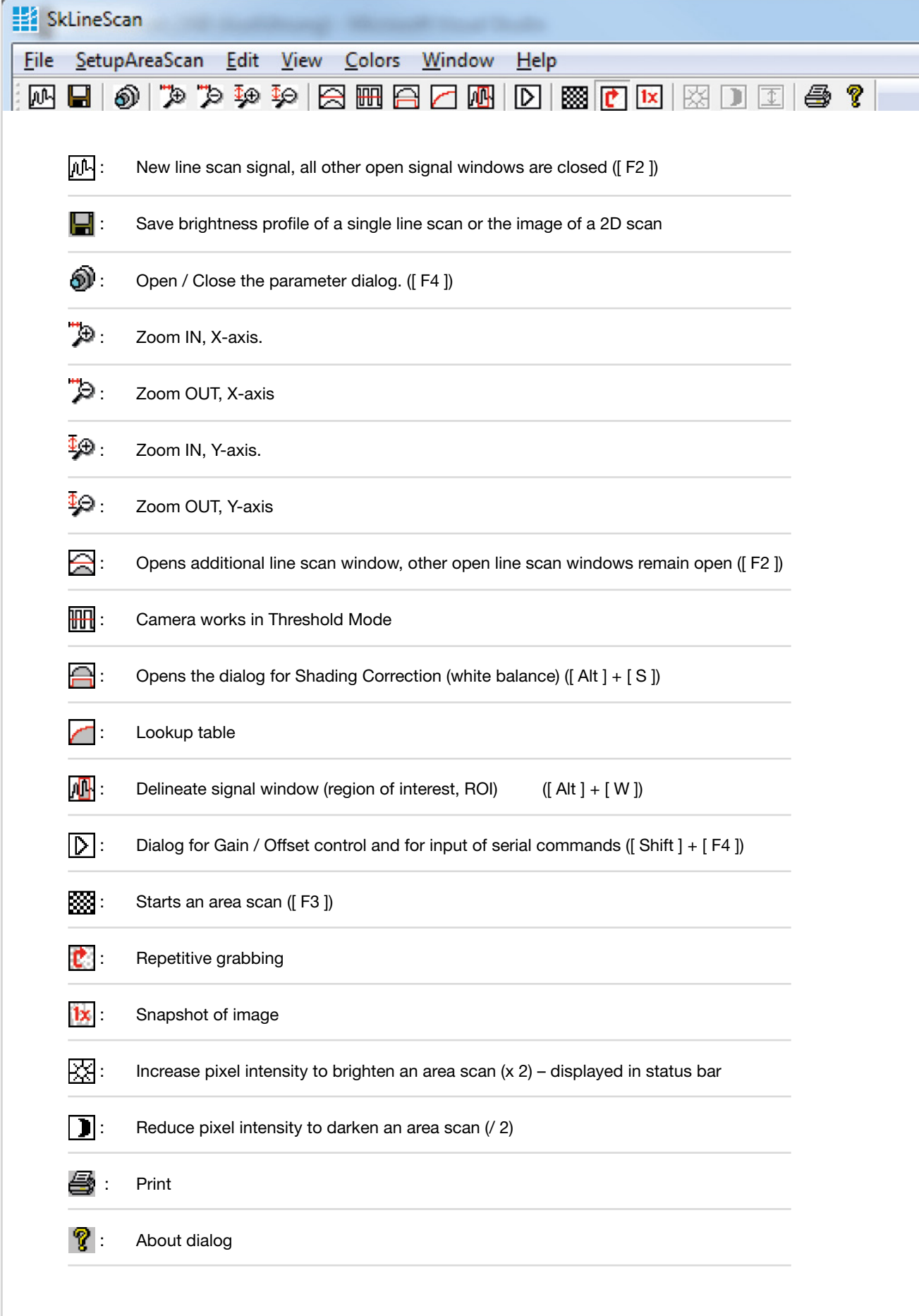

**SkLineScan**

File SetupAreaScan Edit View Colors Window Help

-  : New line scan signal, all other open signal windows are closed ([ F2 ])

---

-  : Save brightness profile of a single line scan or the image of a 2D scan

---

-  : Open / Close the parameter dialog. ([ F4 ])

---

-  : Zoom IN, X-axis.

---

-  : Zoom OUT, X-axis

---

-  : Zoom IN, Y-axis.

---

-  : Zoom OUT, Y-axis

---

-  : Opens additional line scan window, other open line scan windows remain open ([ F2 ])

---

-  : Camera works in Threshold Mode

---

-  : Opens the dialog for Shading Correction (white balance) ([ Alt ] + [ S ])

---

-  : Lookup table

---

-  : Delineate signal window (region of interest, ROI) ([ Alt ] + [ W ])

---

-  : Dialog for Gain / Offset control and for input of serial commands ([ Shift ] + [ F4 ])

---

-  : Starts an area scan ([ F3 ])

---

-  : Repetitive grabbing

---

-  : Snapshot of image

---

-  : Increase pixel intensity to brighten an area scan (x 2) – displayed in status bar

---

-  : Reduce pixel intensity to darken an area scan (/ 2)

---

-  : Print

---

-  : About dialog

# Software for Line Scan Cameras

All of the settings adjusted using the SkLineScan program are saved inside the camera when the program is closed. The adjustments for shading correction, lookup table, gain, offset, integration time, etc can be performed using the SkLineScan program and are available when

the camera is controlled by a customized application. Previously stored parameters are used on start-up and these parameters can be changed during the running of an application. This is useful when adding a Lookup Table or a Shading Correction profile into the camera memory.

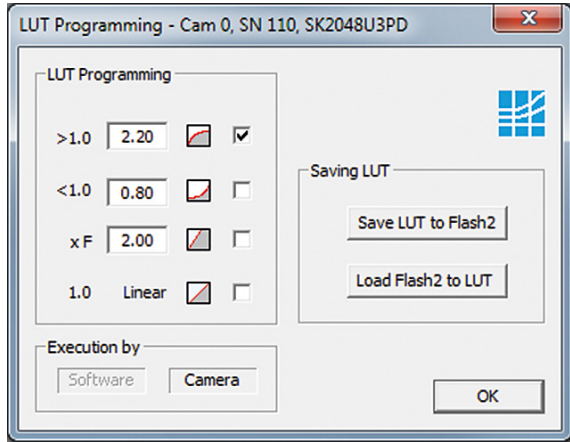

The Lookup Table (LUT) within the camera can be used for pre-processing the signal data. By programming a transformation function, brightness values of the camera can be converted to their corrected values. The transformation of image data can be useful in obtaining better imaging results, such as providing more contrast or higher dynamic range.

The SkLineScan program supports Gamma Correction (convex: gamma > 1.0, concave: gamma < 1.0), and Linear Function with a factor. The Linear LUT with a factor of 1.0 provides the unaltered image data.

The desired transformation function can be activated by inputting the appropriate parameter and clicking on the icon or tick box.

If the camera does not support LUT programming, the transformation can be performed downstream using software.

Press the "Save LUT to Flash2" button to save the currently used LUT in the non-volatile memory of the camera.

## Application: Gamma correction for color images

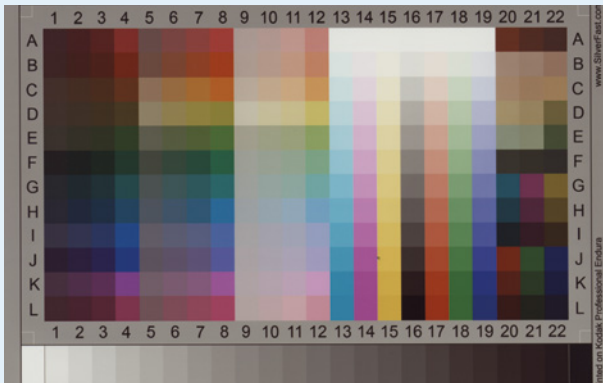

A color image of an it8-target without correction where dark colors are difficult to differentiate

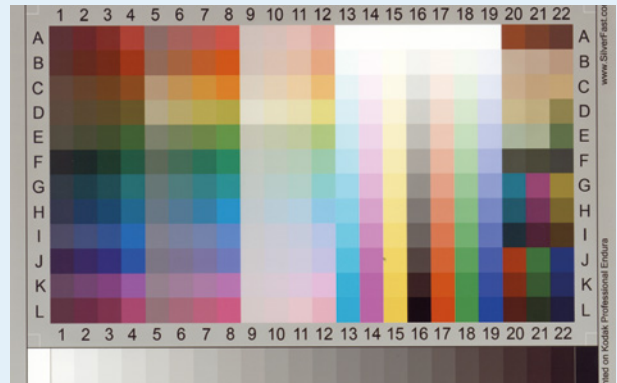

Using the Gamma Correction 2.2, dark colors are brighter and more distinct

## Application: Shading Correction and White Balance

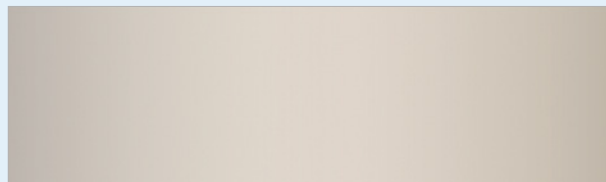
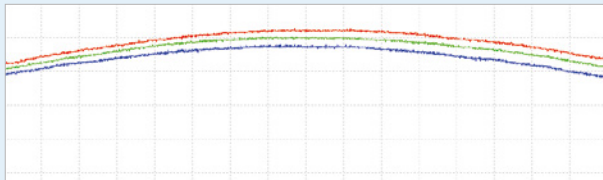

RGB raw signal and area scan without white balance

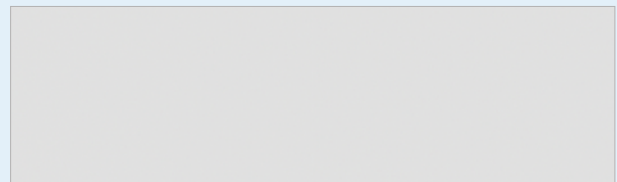

Line signal and area scan with active white balance



# Software Development Kit (SDK)

Schäfter+Kirchhoff offers an SDK with API DLLs and C++ class libraries for GigE and USB 3.0 cameras for the development of customized application software. The SDK also contains examples in C/C++ as a template for the development of individually customized applications. Source code comments and a manual complete the camera programming environment.

The SDK package consists of a core and API:

## 1. Core

The core is required to drive the line scan camera and consists of the device driver and the base DLLs. By using the core, developers can build an efficient installation package for their software. A developer is free to integrate the core within any customized application software for an end customer.

## 2. Application Programming Interface (API)

The API contains a C++ class library as well as compilable projects with example source code. The supported development environment is Microsoft Visual Studio 2012, 2015 and 2017.

Supported operating systems are Windows® 7 / 8.1 / 10, and Linux®. A VI-library for software development using LabView® is also available.

For programming a line scan camera with a Camera Link® interface, the software development kit (SDK) supplied by the manufacturer of the grabber board must be used.

<b>Csk</b>	- Base class
struct sk_interface	Communication structure for the driver
<b>CskInit: Csk</b>	- Initializing class
::Camera	Initializing the camera
::AllocBuffer	Allocate memory in the user area
::FreeBuffer	Release memory
::SetUserBufferPtr	Set pointer to user buffer
<b>CskCtrl: Csk</b>	- Control class
::SetIntegrationTime	Set integration time (ms)
::SetLineFrequency	Set line frequency (kHz)
::SetSyncMode	Set synchronization mode
::SetGain	Set camera gain
::SetOffset	Set camera offset
<b>CskRecord: Csk</b>	- Acquisition class
::SingleLineScan	Get a single line scan
::AreaScan	Acquire a 2D scan
::ContinuousGrab	Start continuous grab
::GetImage	Get single image from a continuous grab
::StopContinuousGrab	Stop continuous grab
<b>CskView: Csk</b>	- View class
::LineScanView	Display a line scan signal
::AreaScanView	Display an area scan
<b>CskInfo: Csk</b>	- class
::GetCamType	Name of current camera
::GetPixWidth	Number of current camera pixels
::GetLineFrequency	Current line frequency in kHz
::GetUserBufferPtr	Pointer to data set in user memory

\* Examples from the class library containing more than 60 ways to control a GigE line scan camera

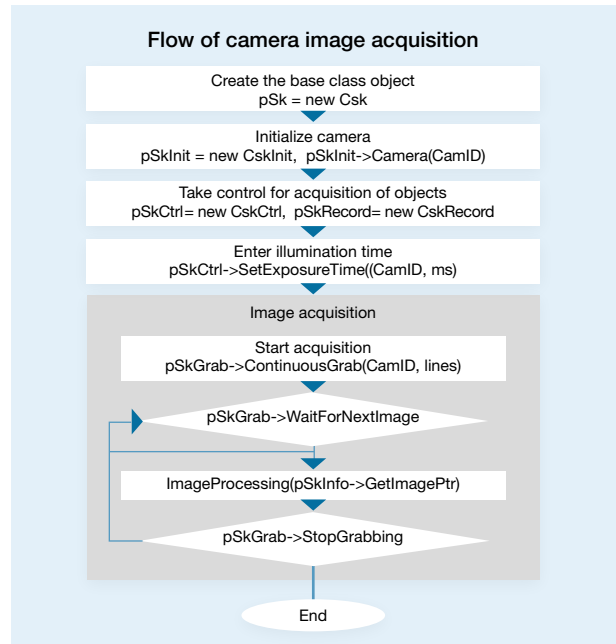
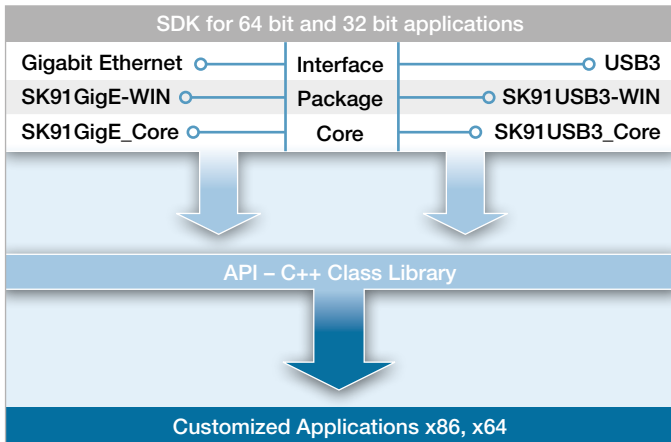

Software Products	SkLineScan Operating Program		
Product	Interface	Operating System	Price
SkLineScan-GigE-WIN_x64_x86	GigE, GigE Vision*)	Windows 7/8.1/10	<a href="https://www.sukhamburg.com/supporte.html">https://www.sukhamburg.com/supporte.html</a>
SkLineScan-U3-WIN_x64_x86	USB 3.0	Windows 7/8.1/10	<a href="https://www.sukhamburg.com/supporte.html">https://www.sukhamburg.com/supporte.html</a>
SkLineScan-U3-LX_x64_x86	USB 3.0	Linux®	<a href="https://www.sukhamburg.com/supporte.html">https://www.sukhamburg.com/supporte.html</a>
<b>Software Development Kit (SDK)</b>			
SK91GigE-WIN	GigE, GigE Vision*)	Windows 7/8.1/10	on request
SK91USB3-WIN	USB 3.0	Windows 7/8.1/10	on request
SK91USB3-LX	USB 3.0	Linux®	on request
SK91USB3-LV	USB 3.0	LabVIEW	on request

\*) SkLineScan and SK91GigE-WIN only support the Schäfter+Kirchhoff GigE line scan cameras. Third party GigE Vision compliant software is fully compatible with the Schäfter+Kirchhoff GigE Vision line scan cameras.

# Accessories

**Focus Adapters, Tubes,  
and Mounting Brackets  
for Line Scan Cameras**



## ■ Accessories

Accessories for Standard Cameras	60
Accessories for Large Format Cameras	64
Lenses	66
Fundamentals: Choosing an Appropriate Camera Lens	66
Scan Lenses C-Mount	70
Photo and Enlarging Lenses	71
Scan Lenses	72
Macro Lenses	74

# Accessories for Standard Format Cameras

## Focus Adapters, Tubes and Mounting Brackets for Sensor Lengths up to 41 mm

The standard format cameras up to 41 mm sensor length use housings with either C-Mount, M40x0.75 or M45x0.75 attachment threads. The adapter AOC-F (A3) is available for connecting F-mount lenses.

The flange focal distance for both C-Mount and F-Mount is standardized. The focus extension is usually integrated in

the lens. With C-mount lenses, extension rings are used for macro imaging. The M39x1/26" (Leica-Mount) is a common lens attachment in image processing for medium diameter images and is appreciated for its robustness. These lenses are always combined with a focus adapter and, if required, with extension rings.

## Overview

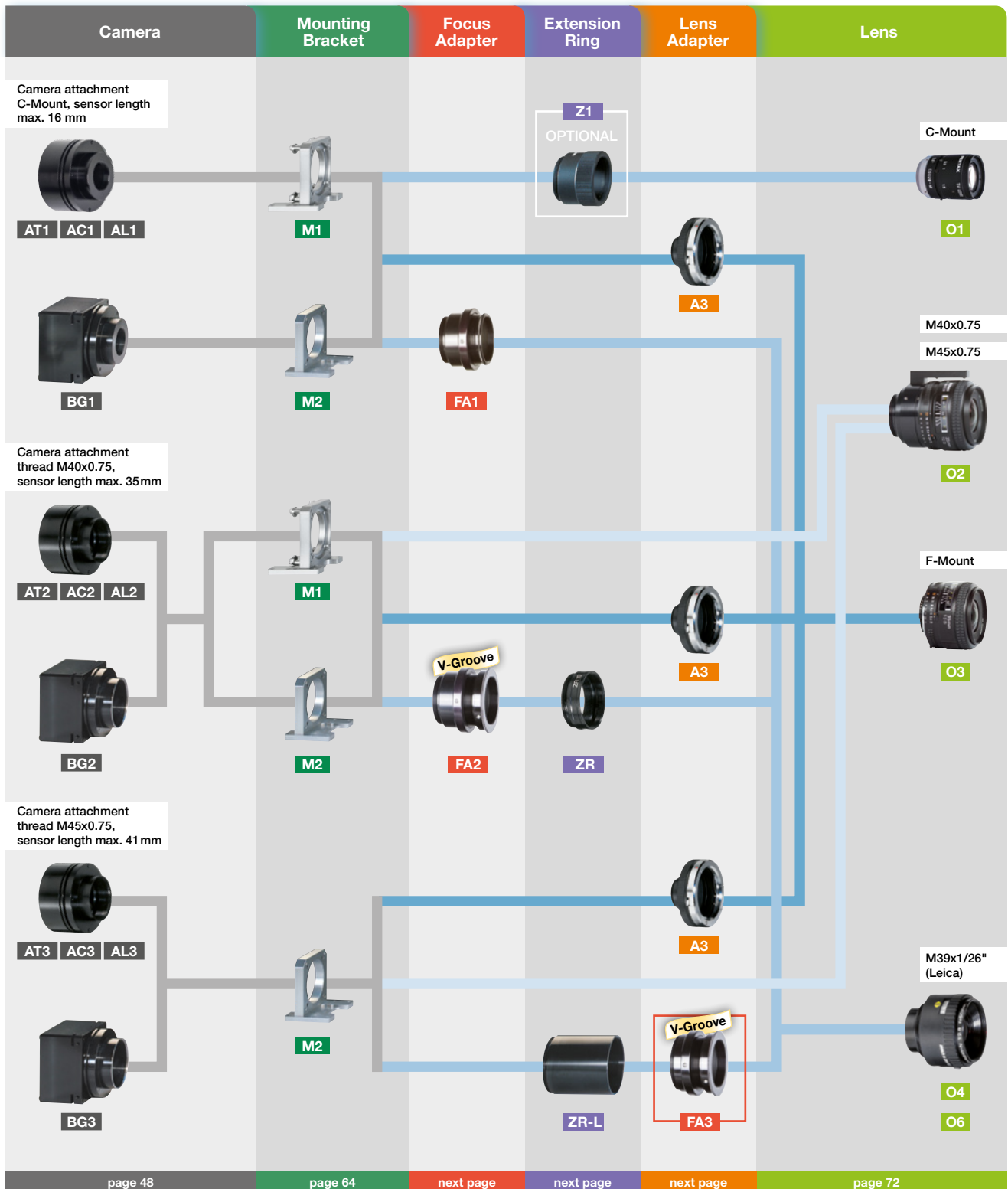

# Components

## Focus Adapters

### M39x1/26" (Leica) — ...

#### FA1



FA22-x

length L:

#### Order Code

42 = M42 x 1  
40 = M40 x 0.75  
39 = M39 x 1/26"  
32 = M32 x 0.75  
C = C-Mount  
22 ... 32 mm

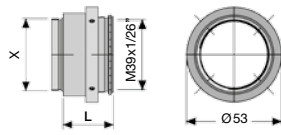

### M39x1/26" (Leica) — M40x0.75

#### FA2



Focus adapter FA22R..., adjustable to any angle of rotation (V-groove)  
M40x0.75, external thread — M39x1/26", internal thread

FA22R-40  
length L: 28 ... 38 mm

FA22RL-40  
length L: 35 ... 45 mm

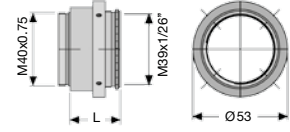

### M39x1/26" (Leica) — M45x0.75

#### FA3

Focus adapter FA22R..., adjustable to any angle of rotation (V-groove)  
M45x0.75, external thread — M39x1/26", internal thread



FA22R-45  
length L:

Order Code  
22 ... 32 mm

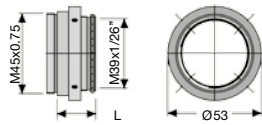

FA22RL-45  
length L:

Order Code  
29 .. 38 mm

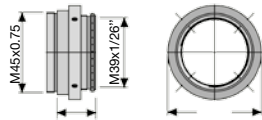

## Extension Rings

### C-Mount

#### Z1

Extension rings C-Mount



EXT-20

#### Order Code

0.5 = Length 0.5 mm  
1.0 = Length 1.0 mm  
5.0 = Length 5.0 mm  
10 = Length 10 mm  
20 = Length 20 mm  
40 = Length 40 mm  
C6 = Set of all 6 extension rings

### M39x1/26" (Leica)

#### ZR

Extension rings M39x1/26"  
attachment threads M39x1/26" external/internal



ZR10

#### Order Code

10 = Length 10 mm  
15 = Length 15 mm  
20 = Length 20 mm  
50 = Length 50 mm

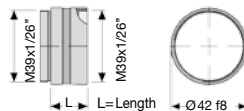

### M45x0.75

#### ZR-L

Extension rings M45x0.75  
attachment threads M45x0.75 external/internal



ZR-L 15

#### Order Code

15 = Length 15 mm  
25 = Length 24.5 mm  
60 = Length 60 mm  
87 = Length 87.5 mm

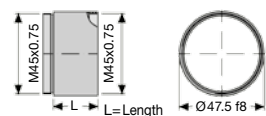

## Lens Adapter

### F-Mount

#### A3

Lens Adapter F-Mount



AOC-F-40

#### Order Code

Attachment thread  
45 = M45x0.75  
40 = M40x0.75  
C = C-Mount  
1"-32-TPI

## Mounting Brackets

### Mounting System SK5105

**M1**

Mounting bracket with mounting diameter 42.0 mm, suitable for cameras with round housing Ax1 and Ax2

SK5105 **Order Code**

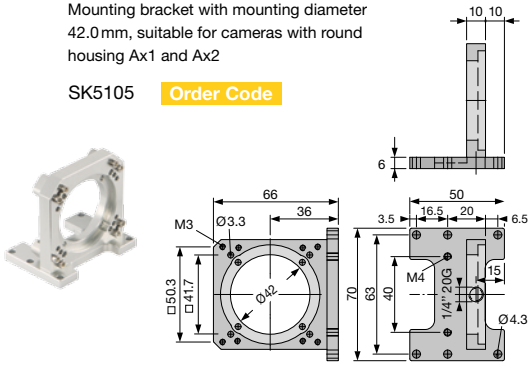

### Mounting System SK5105-L

**M2**

Mounting bracket with mounting diameter 47.5 mm, suitable for cameras with square housing Bxx and round housing Ax3

SK5105-L **Order Code**

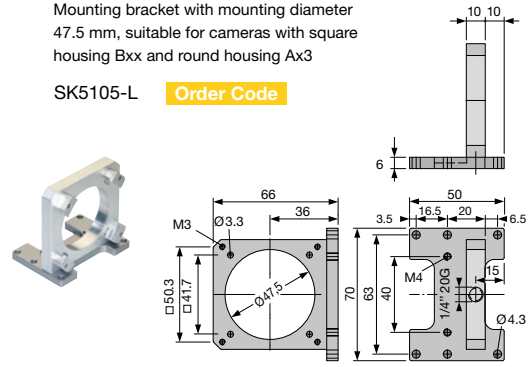

### Mounting System SK5105-2

**M3**

For camera configurations with tube lengths > 55 mm using extension rings ZR

SK5105-2 **Order Code**

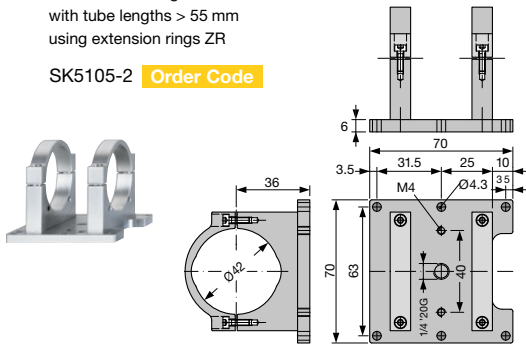

### Mounting System SK5105-2L

**M4**

For camera configurations with tube lengths > 55 mm using extension rings ZR-L

SK5105-2L **Order Code**

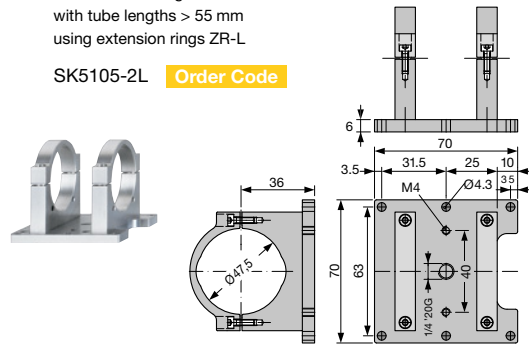

### Clamping Set SK5101

**MC**

SK5101 **Order Code**

(set of 4 pcs.)

Clamp



Allen screw  
DIN 912-M3x12

Detailed data sheets, up-to-date technical information, technical drawings including step files, accessories, extensive technotes section and FAQs:  
[www.sukhamburg.com](http://www.sukhamburg.com)





# Accessories for Large Format Cameras

## Focus Adapters, Tubes and Mounting Brackets for Sensor Lengths up to 71 mm

The large format line scan cameras XL / XB / XC are used together with one of the Schäfter+Kirchhoff high precision focus adapters FA26-S45 or FA26-S55. These adapters with their stable linear tracking rods provide a precise focusing mechanism that can be locked firmly in the final position.

The focus adapter FA26-S45 (attachment thread M45x0.75)

is used in combination with the adapter M39-45 for scan and macro lenses with the attachment thread M39x1/26". The variant FA26-S55 (thread M55x0.75) in combination with the AC46-55 adaptor is applicable for AC46-lenses. Alternative accessories include extension rings, lens-specific adapters and V-groove adapters, with the latter enabling the lens to be mounted at any angle of rotation.

## Overview

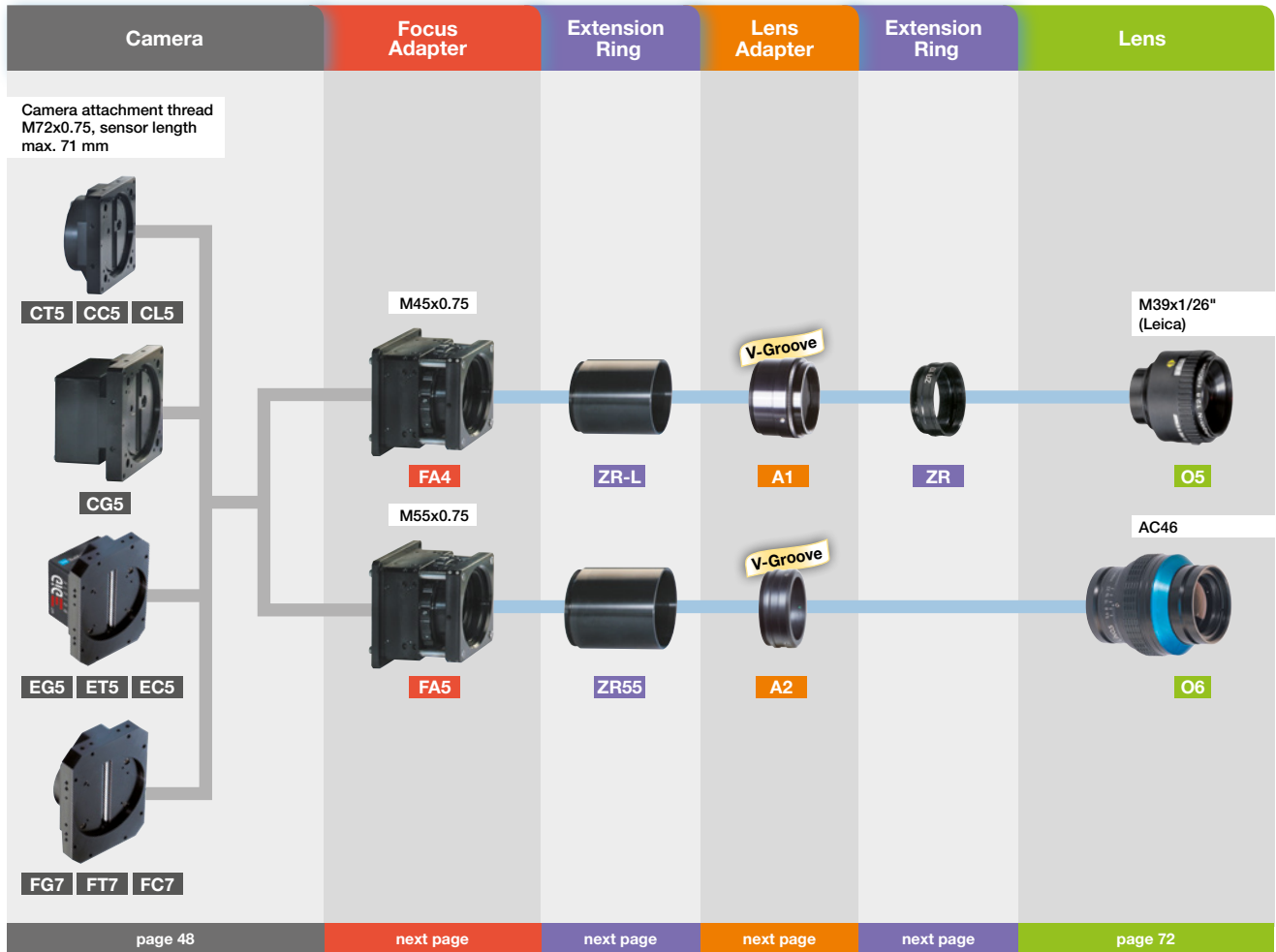

## Focusing and Alignment Mechanism

### Lens focusing, azimuth alignment and locking

- A Linear tracking rods
- B Focusing ring, range  $\pm 15$  mm (1 turn = 10 mm)
- C Screws for locking the focusing encasement, Allen key 1.5
- D V-groove adapter M39x26G-AC43 for free alignment of the lens angle rotation, lens thread M39x1/26"
- E Screw for locking the lens housing, hex Allen key 1.5
- F Aperture stop setting

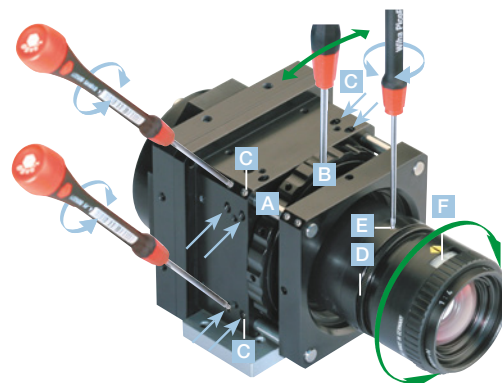



# Components

## Focus Adapters

### M45x0.75

#### FA4

FA26-S45 **Order Code**  
 attachment thread: M45x0.75, female,  
 length (optical path): 40.5 ... 69.5 mm

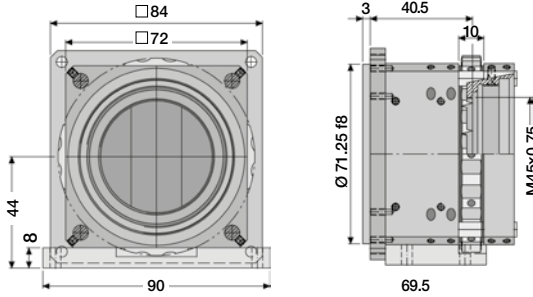

### M55x0.75

#### FA5

FA26-S55 **Order Code**  
 attachment thread: M55x0.75, female,  
 length (optical path): 51 ... 80 mm

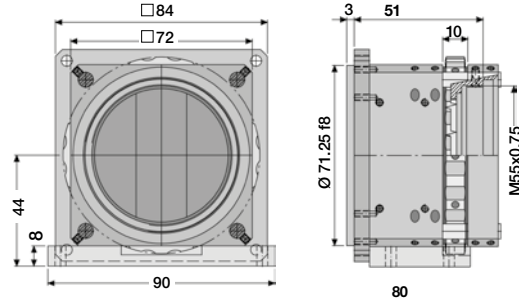

## Extension Rings

### M39x1/26" (Leica)

#### ZR

Extension rings M39x1/26"  
 attachment threads M39x1/26" male/female

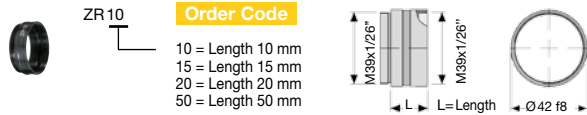

### M55x0.75

#### ZR55

Extension rings M55x0.75, male/female

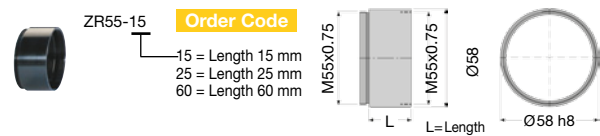

### M45x0.75

#### ZR-L

Extension rings M45x0.75  
 attachment threads M45x0.75 male/female

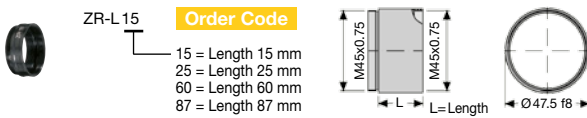

Detailed data sheets, up-to-date technical information, technical drawings including step files, accessories, extensive technotes section and FAQs:  
[www.sukhamburg.com](http://www.sukhamburg.com)



## Lens Adapters

### M45x0.75 — M39x1/26"

#### A1

Lens Adapter M45x0.75 to M39x1/26 (Leica)



Adapter M45x0.75 46mm to AM43



The AM43-M45 accepts the V-groove lens adapter M39x26G-AC43.

Lens Adapter V-Groove AC43 to M39x1/26"



### M55x0.75 — V46

#### A2

Lens adapter 46 mm V-groove – M55 x 0.75 for macro lens inspec.x L5.6/105



AC46-55 **Order Code**  
 The Adapter AC46-55 adds 17.5 mm to the optical tube length. It accepts the AC46 V-groove of the Inspec.x macro lenses.

# Choosing an Appropriate Camera Lens



## Technotes and Fundamentals

For more information, please refer to the extensive technotes section on: [www.sukhamburg.com/support/technotes.html](http://www.sukhamburg.com/support/technotes.html)

The two defining parameters for a line scan camera application are the width of the object and the required resolution. For an object of 80 mm width that must be inspected at a resolution of 20  $\mu\text{m}$  then the camera sensor requires at least 4000 pixels ( $80/0.020 = 4000$ ).

Subsequent criteria would include measurement rate, interface type and spectral sensitivity, which can lead to the selection of one or more suitable line scan camera types. The final selection task is determined by the choice of appropriate lens.

Each lens has specific properties and the major determinants are maximal sensor size and magnification range.

The maximal sensor size traditionally determines how it is used and thereby the lens category:

### CCTV or C-Mount lenses for shorter sensors (< 22 mm)

These were first used with surveillance (CCTV) cameras. Instead of the actual sensor size, manufacturers still use the old tube diameter specifications. For example, a 2/3" lens corresponds to a maximal sensor size of 11 mm, a 1" lens to a sensor of 16 mm.

CCTV lenses have a C-Mount (threaded connector) and an internal focusing mechanism.

Most are designed for distant objects and small magnifications. Macro versions for shorter distances are also available.

### Photo lenses for the traditional film format of 24 mm x 35 mm

Since vignetting at the corners was tolerated in many photo lens designs, most photo lenses should not be used for sensor sizes beyond 36 mm.

Photo lenses also have an internal focusing mechanism and are also designed for distant objects, i.e. small magnifications.

### Scan lenses and macro lenses

These are designed for use with longer sensors and larger magnifications. Unlike CCTV and photo lenses, scan lenses do not have an internal focusing mechanism. Depending on the magnification, they often require a large distance between the sensor and the lens, which is achieved with extension tubes and a focus adaptor for focusing.

Within these categories of use, other parameter choices include the focal length of the lens, which determines the working distance and the required space, or the f-number, which determines the signal amplitude, the diffraction limit of resolution and, together with the magnification, the depth of focus.

The following collection of optical formulae is intended to help with the design of the imaging system and to provide preliminary information about the performance to be expected. The identifiers used are explained in Figure 1.

Detailed specifications of the available lenses are provided on pages 70 to 75.

**Figure 1:** Schematic depiction of the imaging system and definition of variables used

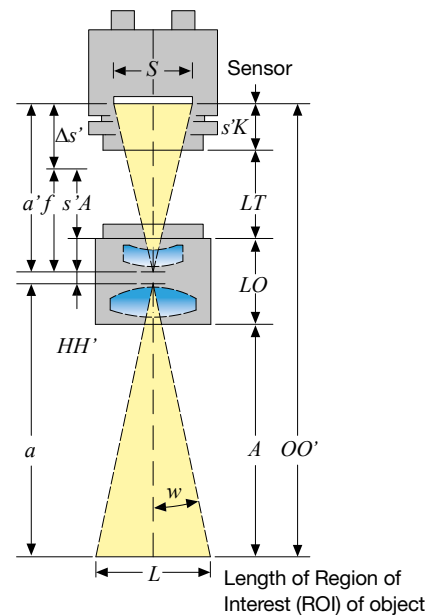

$f$	Lens focal length (mm)	$HH'$	Principal point distance (mm) (can lengthen or shorten $OO'$ )
$S$	Sensor length (mm)	$sK$	Camera flange length
$L$	Length of Region of Interest (ROI) of object (mm)	$sA$	Flange focal length (mm)
$a$	Object range (mm)	$\Delta s'$	Lens extension (mm)
$a'$	Image distance: Distance from sensor to $HH'$ (mm)	$LT$	Tube length consisting of focus adapter FA22-... and extension rings ZR... (mm)
$\beta$	Magnification	$LO$	Lens length (mm)
$w$	Field angle	$A$	Working distance (mm)
$OO'$	Distance from sensor to measured zone (mm)		

**F1: Imaging equation**

Object range and image range are related by the imaging focal length. The formulae F3 to F6 are derived from

$$\frac{1}{a} + \frac{1}{a'} = \frac{1}{f}$$

**F2: Magnification  $\beta$ :**

The magnification is defined as

$$\beta = \frac{\text{sensor length}}{\text{ROI length}} = \frac{S}{L} = \frac{a'}{a}$$

**Example:**

ROI length  $L = 290$  mm,  
 Sensor length  $S = 28.7$  mm:  
 $\beta = S/L = 28.7/290 = 1/10.1 = 0.099$

**F3: Lens extension  $\Delta s'$**

For a very distant object ("at infinity"), the sensor has to be placed in the focal plane of the lens, i.e.  $a' = f$ . To focus a nearer object, the distance between lens and sensor has to be increased by using a lens extension

$$\Delta s' = f \cdot \beta$$

For C-Mount and Photo lenses, the lens extension is achieved by using their internal focusing mechanism, up to a specified minimum object distance. Extension rings are available for C-Mount lenses to increase the extension further and to focus nearer objects. This is a convenient solution but might impair imaging quality.

For scan and macro lenses, the solution is more complicated. The required tube length  $LT$  is calculated from (F3) and (F4) and implemented with extension rings and with a focus adapter as well.

**Example 1:** Magnification  $\beta = 0.099$  and focal length  $f = 50$  mm:  
 $\Delta s' = 50 \text{ mm} \times 0.099 = 4.95 \text{ mm}$   
**Example 2:** In macro imaging with  $\beta = 1$  (1:1 imaging), the lens extension equals the focal length  $f$ .

**F4: Tube length  $LT$**

$LT = \text{flange focal length} + \text{lens extension}$   
 (Camera flange length)  
 $LT = s'A + \Delta s' - s'K$

**Example:** Rodagon 4.0/80, focal length  $f = 81$  mm,  $\beta = 1/6$ ,  
 $s'A = 74.7$  mm,  $s'K = 19.5$  mm:  
 $\Delta s' = f\beta = 81 \text{ mm} / 6 = 13.5 \text{ mm}$   
 $LT = 74.7 \text{ mm} + 13.5 \text{ mm} - 19.5 \text{ mm} = 68.7 \text{ mm}$

By using: focus adapter FA22-40 22.0 mm  
 + focus adapter extension 6.7 mm  
 + 2x extension rings ZR20 40.0 mm  
**Total = 68.7 mm**

**F5: Sensor to object distance  $OO'$**

With magnification  $\beta$  and focal length  $f$  then:

$$OO' = \left(\beta + \frac{1}{\beta} + 2\right) \cdot f + HH'$$

For  $\beta \leq 1/10$  then  $OO'$  approximates  $(1/\beta + 2) \cdot f + HH'$ .

**Example 1:** Video lens B1614A, focal length  $f = 16$  mm,  
 $HH' = 3.85$  mm,  $L = 290$  mm,  $S = 13.3$  mm:  
 $OO' = (L/S + 2) \cdot f + HH'$   
 $= (290/13.3 + 2) \cdot 16 \text{ mm} + 3.85 \text{ mm} = 384.7 \text{ mm}$  (as an approximation)

**Example 2:** Rodagon 4.0/80, focal length  $f = 81$  mm,  
 $HH' = -2.5$  mm,  $\beta = 1/6$ :  
 $OO' = (1/\beta + 2) \cdot f + HH'$   
 $= (1/6 + 2) \cdot 81 \text{ mm} - 2.5 \text{ mm} = 658.7 \text{ mm}$

The value  $OO'$  provides an indication of the required space (the length of camera housing attached to the sensor, without taking into account the space required for connectors and cables).

**F6: Calculation of focal length  $f$**

With magnification  $\beta$  and sensor to object distance  $OO'$ . If there is a space restriction, the maximum focal length is calculated from the sensor to object distance  $OO'$  by

$$f = \frac{OO'}{1/\beta + \beta + 2} \quad \text{or for } \beta < 0.1 \text{ approximately } f = \frac{OO'}{1/\beta + 2}$$

**Example:**  
 Magnification  $\beta = 0.099$  and  $OO' = 605$  mm:  
 Focal length  $f = 605 \text{ mm} / (10.1 + 2) = 50 \text{ mm}$

**F7: Field angle  $w$**

The field angle  $w$  is determined by the sensor length  $S$ , the focal length  $f$  and magnification  $\beta$ :

$$w = \arctan\left(\frac{S}{2 \cdot f \cdot (1 + \beta)}\right)$$

The field angle is used for calculating the edge intensity, F10.

**F8: Depth of focus**

The depth of focus  $2z$  is calculated from

$$2z = 2 \cdot \Delta y' \cdot K \cdot \frac{1}{\beta} \left(1 + \frac{1}{\beta}\right)$$

using the F-number  $K$ , the pixel pitch (mm)  $\Delta y'$ , and the magnification  $\beta$ .

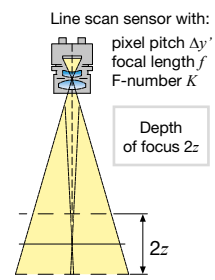

**Example:** Pixel pitch  $\Delta y' = 0.014$  mm  
 1/magnification  $1/\beta = 10$   
 F-number  $K = 4$   
 then  $2z = 2 \cdot 0.014 \text{ mm} \cdot 4 \cdot 10 \cdot (1 + 10) = 12.3 \text{ mm}$

F-number $K$	2	2.8	4	5.6	8	11	22	32
Depth of Focus $2z$ (mm)*	6.2	8.6	12.3	17.2	24.6	33.9	67.8	98.6
Relative signal amplitude	16	8	4	2	1	1/2	1/4	1/8

\* for  $\Delta y' = 0.014$  mm and  $\beta = 1/10$

# Choosing an Appropriate Camera Lens

## F9: Effective F-number $K'$ , relative signal amplitude

For small magnifications  $\beta \leq 0.1$  when calculating signal amplitude or the limit of lens resolution caused by diffraction (see F11), the F-number  $K$  (=focal length/aperture diameter) is replaced by an effective F-number  $K'$  (=image distance/aperture diameter).

With a nominal F-number  $K$  and small magnification  $\beta$  the effective F-number  $K'$  is calculated from:

$$K' = K \cdot (1 + \beta)$$

**Example:** Nominal F-number  $K = 4$ , magnification  $\beta = 1$ :  
effective F-number  $K' = 2 \cdot K = 8$

The relative signal amplitude of two effective F-numbers is given by

$$\text{Relative signal amplitude } R = \left( \frac{K'_2}{K'_1} \right)^2$$

For constant  $\beta$ , the effect of stopping down a  $K=1.4$  lens is as follows

F-number $K$	1.4	2.0	2.8	4.0	5.6	8
Relative signal amplitude $R$	1	0.5	0.25	0.125	0.06	0.016

## F11: Diffraction limit

The resolution of a lens is limited by diffraction and declared using the effective F-number  $K'$  (see F9).

The best possible resolution is achieved by closing the lens aperture by 1 to 2 steps, so that the lens resolution approaches the diffraction limit.

Adjacent image elements become distinguishable when their distance is:

$$\Delta y' \geq 2,4 \cdot \lambda \cdot K'$$

With the optical wavelength  $\lambda$  for visible radiation is defined as 550 nm then:

Effective F-number $K'$	Diffraction limit Resolution* $\Delta y'_{\min}$ [ $\mu\text{m}$ ]
2	2.6
2.8	3.7
4	5.3
5.6	7.4
8	10.8
11	14.5
16	21.1
22	29

\*at wavelength  $\lambda = 550 \text{ nm}$

**Example:** effective F-number  $K' = 8$   
wavelength  $\lambda = 550 \text{ nm}$   
 $\Delta y'_{\min} = 10.6 \mu\text{m}$

## F10: Edge intensity

The edge intensity of a line scan signal is determined by the illumination and the field angle  $w$  (see F7).

Even for homogeneous illumination, the signal amplitude decreases towards the ends of the line:

$$\text{Edge intensity [\%]} = 100 \cdot \cos^4(w)$$

**Rule of thumb:** The focal length should be equal to or greater than the sensor length. In these examples, the edge intensities are 90% and 73% of the center intensity, respectively.

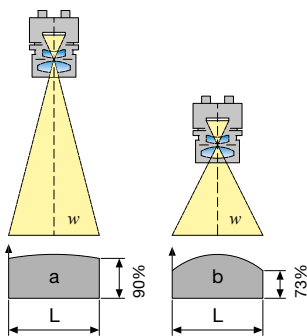

**Example:** Edge intensities calculated for two different field angles using the same sensor length  $S = 28.7$  and magnification  $\beta = 0.25$ :

- a) focal length  $f = 50 \text{ mm}$     b) focal length  $f = 28 \text{ mm}$   
 field angle  $w = 13^\circ$             field angle  $w = 22.3^\circ$   
 edge intensity = 90%                edge intensity = 73%



# Lenses: Scan Lenses C-Mount

C-mount lenses are suitable for a wide magnification range but can only be used for shorter line sensors. For smaller fields of view in macro imaging, the tube is extended with extension rings, which can reduce the free working distance below the minimum specified for the lens.



## C-Mount

Order Code	Focal length $f$ [mm]	F-number $K$	Nominal format	Max. CCD sensor length $S$ [mm]	Principal point distance $HH'$ [mm]	Length $LO$ [mm]	Outer diameter [mm]	Filter thread	Minimum focus distance (lens front edge to object plane) $A$ [mm]
------------	-----------------------------	-----------------	----------------	---------------------------------------	-------------------------------------------	------------------------	------------------------	---------------	-------------------------------------------------------------------------

### CM1 C-Mount CCTV Lenses

1	FL-CC0815B-VG	8.5	1.5	2/3"	11	3.85	40	42	M40.5x0.5	200
2	FL-CC1614A-VG	16	1.4	2/3"	11	3.85	33	30	M27x0.5	300
3	FL-BC1214D-VG	12.5	1.4	1"	16	21.43	50	42	M40.5x0.5	300
4	FL-BC1218A-VG	12.5	1.8	1"	16	12.15	40	42	M40.5x0.5	300
5	FL-BC2514D-VG	25	1.4	1"	16	0.53	37.3	30	M27x0.5	300
6	FL-BC2518-VG	25	1.8	1"	16	-2.93	40	42	M40.5x0.5	600
7	FL-BC5014A-VG	50	1.4	1"	16	-2.59	48	48	M46x0.75	1000

8	Aquamarine 2.0/28 C	28	2	13x18	24	-2.9	35.5	34	M30.5x0.5	174
9	Aquamarine 2.0/35 C	35	2	13x18	24	-3.88	40.8	34	M30.5x0.5	80
10	Tourmaline 2.0/35 C	35	2	13x18	24	-8.38	51.7	50	M37x0.75	168
11	Tourmaline 2.8/50 C	50	2.8	13x18	24	-3.1	48.9	34	M30.5x0.5	252

12	FL-CC1214A-2M	12	1.4	2/3"	11	20.1	45.7	29.5	M27x0.5	100
13	FL-CC1614-2M	16	1.4	2/3"	11	1.97	33.2	29.5	M27x0.5	250
14	FL-CC1614A-2M	16	1.4	2/3"	11	0.23	32.2	29.5	M27x0.5	100
15	FL-CC2514-2M	25	1.4	2/3"	11	-10.5	32	29.5	M27x0.5	250
16	FL-CC3516-2M	35	1.6	2/3"	11	-23	35.4	29.5	M27x0.5	900
17	FL-CC5028-2M	50	2.8	2/3"	11	-2.59	34	29.5	M27x0.5	900
18	FL-BC2518-9M	25	1.8	1"	16	7.02	57.5	42	M40.5x0.5	100
19	FL-BC3518-9M	35	1.8	1"	16	-5.77	60	42	M40.5x0.5	150
20	FL-BC5024-9M	50	2.4	1"	16	-13.06	69	42	M40.5x0.5	200
21	FL-BC7528-9M	75	2.8	1"	16	-27.67	81	42	M40.5x0.5	250
22	MeVis-C 1.8/12	12	1.8	1"	16	30.9	67.6	42	M35.5x0.5	30
23	MeVis-C 1.6/16	16	1.6	1"	16	17.9	55.7	42	M35.5x0.5	150
24	MeVis-C 1.6/25	25	1.6	1"	16	1.9	44.1	42	M35.5x0.5	260
25	MeVis-C 1.6/35	35	1.6	1"	16	6.4	59.4	42	M35.5x0.5	370
26	MeVis-C 1.8/50	50	1.8	1"	16	-5.5	71.2	42	M35.5x0.5	670

### Configuration Example: Line Scan Camera SK512U3SH with Lens MeVis-C1.6/25 for Field of View 80 mm

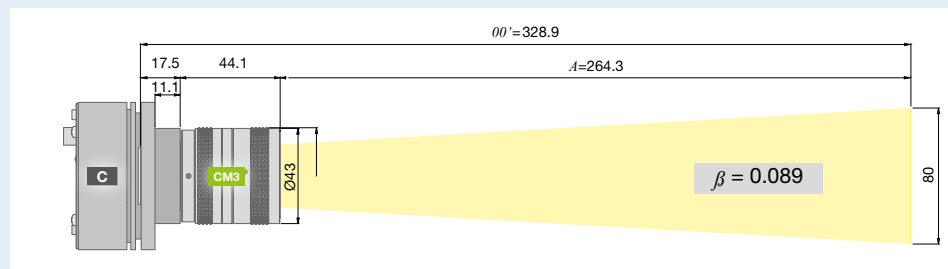

Sensor length $S$	7.17 mm
ROI length $L$	80 mm
Magnification $\beta$	0.089
Focal length $f$	25 mm
$HH$	1.9 mm
$OO$	329 mm

$\beta$  calculated from F2,  
 $OO$  calculated from F5  
(see page 67)

### System Components

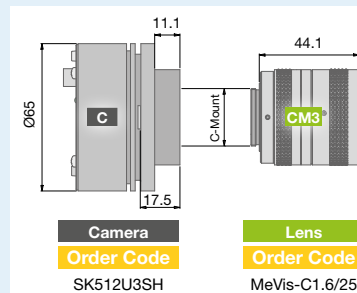

The Schäfter+Kirchhoff line scan cameras which can be used with C-Mount lenses have a corresponding female C-Mount (1"/32 TPI) thread.

No additional components are required if the working distance  $A$  is larger than the minimum specified in the table above.

# Lenses: Photo and Enlarging Lenses

Fixed focal length lenses for large image scales. Due to the F-mount attachment they are appropriate for medium sensor lengths. For the cost-effective photo lenses AF... Schäfter+Kirchhoff offer adapter combinations with integrated locking for the focus and aperture ring.



## Photo Lenses

Order Code	Focal length $f$ [mm]	F-number $K$	Max. CCD sensor length $S$ [mm]	Magnification range $\beta$	Flange focal Length ( $x$ ) $s A$ [mm]	Length $LO$ [mm]	Outer diameter [mm]	Filter thread	Min. close focus range (lens front edge to object plane) $A$ [mm]
------------	-----------------------------	-----------------	---------------------------------------	--------------------------------	----------------------------------------------	------------------------	------------------------	---------------	-------------------------------------------------------------------------

### FM1 M40x0.75 attachment

1	SK2.8/20-40	20	2.8	36	1:8.3 - 0	19.5	69.5	69	M62x0.75	250
2	SK1.8/50-40	50	1.8	36	1:6.6 - 0	19.5	66	63.5	M52x0.5	450

### FM2 M45x0.75 attachment

3	SK2.8/20-45	20	2.8	36	1:8.3 - 0	19.5	69.5	69	M62x0.75	250
4	SK1.8/50-45	50	1.8	36	1:6.6 - 0	19.5	66	63.5	M52x0.5	450

### FM3 F-Mount (bayonet Ø44 mm)

5	AF2.8/20D	20	2.8	36	1:8.3 - 0	46.5	42.5	69	M62x0.75	250
6	FL-YFL3528	35	2.8	45	1:6.65 - 0	46.5	56.8	72	M62.5x0.75	190
7	Rodagon-F 40	40	4	44	1:2 - 0	46.5	21	59	M40.5x0.5	94
8	inspec.x M1.4/50	50	1.4	43.5	1:6.67 - 0	42.6	45	70	M58x0.75	355
9	AF1.8/50D	50	1.8	36	1:6.6 - 0	46.5	39	63.5	M52x0.5	450
10	FL-YFL5028	50	2.8	45	1:6.13 - 0	46.5	57.8	72	M62.5x0.75	250
11	Rodagon-F 50	50	2.8	44	1:2 - 0	46.53	27.8	59	M40.5x0.5	124
12	Rodagon-F 60	60	4	44	1:2 - 0	46	40.2	59	M40.5x0.5	159

Detailed data sheets, up-to-date technical information, technical drawings including step files, accessories, extensive technotes section and FAQs:  
[www.sukhamburg.com](http://www.sukhamburg.com)



## Configuration Example: Line Scan Camera SK2048U3JR with Lens SK2.8/28-40 for Field of View 80 mm

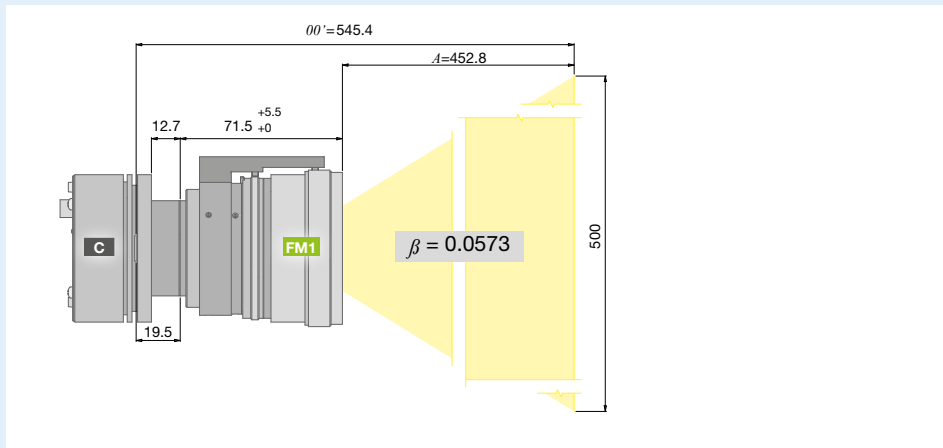

Sensor length: 28.67 mm  
Field of View: 500 mm  
Magnification  $\beta$ : 0.0573  
Focal length: 28 mm  
 $OO'$ : 545 mm

$\beta$  calculated from F2,  
 $OO'$  calculated from F5  
(see page 67)

## System Components

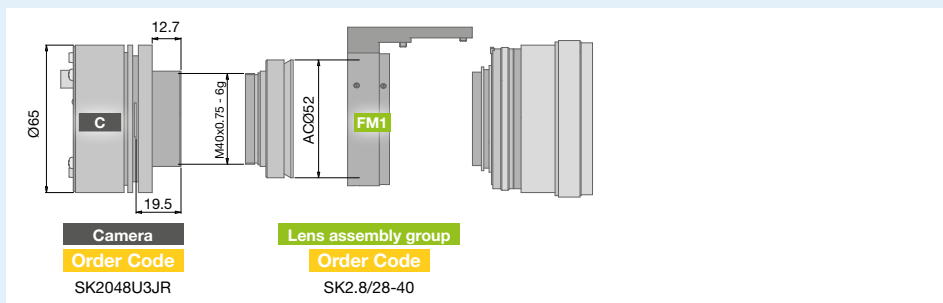

The Schäfter+Kirchhoff line scan cameras which can be used with Photo lenses have either a M40x0.75 or a M45x0.75 lens thread. These fit directly to the lenses No. 1-5 and 6-10, respectively. Adapters are used with standard F-Mount lenses.

# Lenses: Scan Lenses

Scan lenses are designed for typical magnifications (about 1:3 to 1:15) and rather short working distances. This improves the image quality at the margins compared to photo lenses.

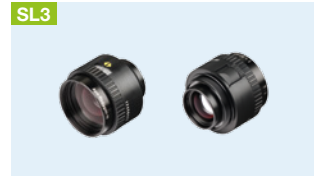

## Scan Lenses

Order Code	Focal length	F-number	Max. CCD sensor length	Optimum magnification	Magnification range	Flange focal length (f <sub>s</sub> )	Principal point distance	Length	Outer diameter	Filter thread	Imaging at optimum magnification β <sub>o</sub>		
	f [mm]	K	S [mm]	β <sub>o</sub>	β	s A [mm]	HH [mm]	LO [mm]	[mm]		s A <sub>B</sub> [mm]	OO [mm]	A [mm]

### SL1 V38-Mount

1	Pyrite 2.8/28 V38	28	2.8	30	1:10	1:2 – 0	25.2	-2.94	28.6	46	M37x0.75	28.1	351	295
2	Pyrite 2.8/35 V38	35	2.8	30	1:10	1:2 – 0	30.7	-3.54	28.6	46	M37x0.75	34.2	419	356
3	Pyrite 2.8/40 V38	40	2.8	43.2	1:10	1:2 – 0	38.1	-2.19	28.6	46	M37x0.75	42.3	500	429
4	Pyrite 4.0/45 V38	45	4	43.2	1:10	1:2 – 0	42.6	-1.79	28.6	46	M37x0.75	47.3	564	488
5	Pyrite 2.8/50 V38	50	2.8	43.2	1:10	1:2 – 0	42	-3.07	28.6	46	M37x0.75	47.0	604	528
6	Pyrite 4.0/60 V38	60	4	60	1:10	1:2 – 0	53.4	-1.89	28.6	46	M37x0.75	59.4	725	637
7	Pyrite 4.0/80 V38	80	4	80	1:10	1:2 – 0	77.7	-1.81	28.6	46	M37x0.75	85.7	970	856
8	Pyrite 4.5/90 V38	90	4.5	90	1:10	1:2 – 0	86	-3.62	28.6	46	M37x0.75	95.1	1100	976
9	Pyrite 5.6/100 V38	100	5.6	108.2	1:10	1:2 – 0	95.9	-2.38	28.6	46	M37x0.75	106.1	1236	1101

### SL2 M39x1/26" (Leica)

10	Rodagon 4.0/35 B'-0.05	35	4	40	1:20	1:5 – 1:33.3	30.4	0.11	30.9	50	M40.5x0.5	32.2	774	711
11	Rodagon-WA 4/40 B'-0.1	40	4	43	1:10	1:4 – 1:20	36.5	0.17	30.7	50	M40.5x0.5	40.5	489	418
12	Rodagon 2.8/50 B'-0.1	50	2.8	43	1:10	1:2 – 1:15	43.5	-2.75	30.7	50	M40.5x0.5	48.5	603	524
13	Rogonar-S 2.8/50 B'-0.1	50	2.8	44	1:10	1:2.5 – 1:13.33	48.37	1.2	30.73	50	M40.5x0.5	53.5	620	535
14	Rogonar-S 4.5/60 B'-0.25	60	4.5	56	1:4	1:2 – 1:10	52.5	0.57	30.6	50	M40.5x0.5	67.6	377	279
15	Rodagon-WA 4/60 B'-0.13	60	4	55	1:8	1:4 – 1:15	55.5	-2.44	31	50	M40.5x0.5	63.2	619	525
16	Rodagon 4.0/60 B'-0.25	60	4	56	1:4	1:2 – 1:16.7	56	-2	30.6	50	M40.5x0.5	71.5	385	283
17	Rogonar-S 4.5/75 B'-0.25	75	4.5	85	1:4	1:2 – 1:10	65.5	0.83	30.6	50	M40.5x0.5	84.0	463	349
18	Rodagon 4.0/80 B'-0.25	80	4	62	1:4	1:2 – 1:16.7	74.5	-2.6	30.8	50	M40.5x0.5	94.8	504	379
19	Rogonar-S 4.5/90 B'-0.25	90	4.5	65	1:4	1:2 – 1:8	80	1.16	30.6	50	M40.5x0.5	102.5	563	430
20	Rodagon 5.6/105 B'-0.17	105	5.6	108	1:6	1:2 – 1:16.7	101.5	-0.88	30.5	50	M40.5x0.5	119.2	868	718
21	Rodagon 5.6/135 B'-0.17	135	5.6	150	1:6	1:2 – 1:10	128	-2.45	31	50	M40.5x0.5	150.6	1106	924

### SL3 M39x1/26" (Leica), High Resolution

22	Apo-Rodagon N 2.8/50 B'-0.1	50	2.8	44	1:10	1:2 – 1:20	46	-2.3	30.8	50	M40.5x0.5	51.0	605	523
23	Apo-Rodagon N 4.0/80 B'-0.1	80	4	86	1:10	1:2 – 1:15	78	-2.5	35	50	M40.5x0.5	86.4	1008	886
24	Apo-Rodagon N 4.0/90 B'-0.1	90	4	90	1:10	1:2 – 1:15	84.9	-3.2	31.2	50	M40.5x0.5	93.9	1087	962
25	Apo-Rodagon N 4.0/105 B'-0.17	105	4	100	1:6	1:2 – 1:16	99.2	-3.3	36	50	M40.5x0.5	116.7	856	703



# Lenses: Scan Lenses



## Scan Lenses

Order Code	Focal length	F-number	Max. CCD sensor length	Optimum magnification	Magnification range	Flange focal length ( $s A$ )	Principal point distance	Length	Outer diameter	Filter thread	Imaging at optimum magnification $\beta_o$			
	$f$ [mm]	$K$	$S$ [mm]	$\beta_o$	$\beta$	$s A$ [mm]	$HH$ [mm]	$LO$ [mm]	[mm]		Flange focal length ( $s A_\beta$ ) [mm]	Distance sensor to object $OO$ [mm]	Distance lens to object $A$ [mm]	
<b>SL4 M45x0.75, High Resolution</b>														
26	inspec.x L 4.0/60 B'-0.033	60	4	70.9	1:30.3	1:5 - 0	55.2	8.5	42.6	51	M49x0.75	57.2	1968	1868
<b>SL5 V48-Mount, High Resolution</b>														
27	Emerald 2.8/28 V48-LD	28	2.8	43.2	1:33	1:10 - 0	60	56.82	76.7	65	M62x0.75	60.9	1060	923
28	Emerald 2.8/28 V48-SD	28	2.8	43.2	1:20	1:10 - 0	60	56.58	76.8	65	M62x0.75	61.4	691	553
29	Emerald 2.2/50 V48	50	2.2	43.2	1:10	1:6 - 0	45	-10.9	26.6	55	M43x0.75	50.1	609	532
30	Emerald 4.0/60 V48	60	4	43.2	1:4	1:2 - 0	55	-1.89	25.9	55	M43x0.75	70.0	374	278
31	Emerald 4.0/80 V48	80	4	43.2	1:10	1:4 - 0	80	-1.81	25.1	55	M43x0.75	88.0	970	857
32	Emerald 2.8/100 V48-SD	100	2.8	43.2	1:20	1:6 - 1:50	98.3	-16.38	41.9	55	M43x0.75	103.3	2191	2046
33	Emerald 2.9/100 V48-LD	100	2.8	43.2	1:50	1:10 - 0	100	-17.32	43	55	M43x0.75	102.0	5233	5088
34	Emerald 5.6/135 V48	135	5.6	90	1:10	1:2 - 0	120	-3.04	40.3	55	M49x0.75	133.6	1639	1465

Detailed data sheets, up-to-date technical information, technical drawings including step files, accessories, extensive technotes section and FAQs: [www.sukhamburg.com](http://www.sukhamburg.com)



### Configuration Example: Line Scan Camera SK2048U3SH with Lens Apo-Rodagon D2 4.0/75mm for Field of View 60 mm

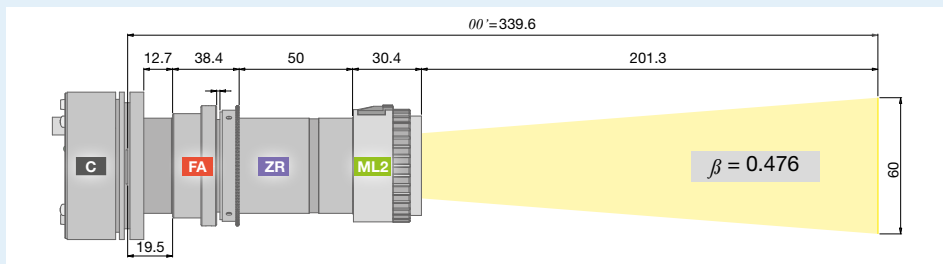

Sensor length: 28.67 mm  
 Field of View: 60 mm  
 Magnification  $\beta$ : 0.476  
 Focal length: 74.8 mm  
 Flange focal length: 72.1 mm  
 $HH$ : -2.2 mm  
 $OO$ : 229.6 mm

$\beta$  calculated from F2,  
 $OO$  calculated from F5  
 (see page 67)

### System Components

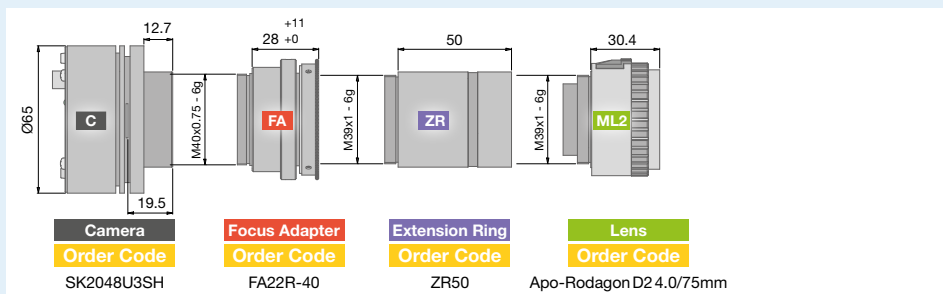

Scan and macro lenses require a focus adapter for focusing and one or more additional extension rings. Extension rings and the focus adapter together provide the tube length LT (see page 67, F4):  
 $LT = 72.1 + 35.6 - 19.5$  mm  
 $= 88.4$  mm  
 $= 50 + 38.4$  mm

# Lenses: Macro Lenses

Macro lenses are designed for rather short working distances and image scales of about 1: 0.7 to 1: 3. The image field curvature is therefore minimal. The design for a small magnification range leads to minimal image errors.



## Macro Lenses

Order Code	Focal length	F-number	Max. CCD sensor length	Optimum magnification	Magnification range	Flange focal length (f)	Principal point distance	Length	Outer diameter	Filter thread	Imaging at optimum magnification $\beta_o$		
	$f$ [mm]	$K$	$S$ [mm]	$\beta_o$	$\beta$	$s A$ [mm]	$HH$ [mm]	$LO$ [mm]	[mm]		Flange focal length ( $\beta_o$ )	Distance sensor to object	Distance lens to object
											$s A_B$ [mm]	$OO$ [mm]	$A$ [mm]

### ML1 V38-Mount, High Resolution

1	Pyrite 5.6/80/1.0x V38 $\beta' = -1.0$	80	5.6	100	1:1	1:0.5 – 1:2	80	-1.31	28.6	46	M37x0.75	162.4	328	137
2	Pyrite 4.5/90/0.3x V38 $\beta' = -0.30$	90	4.5	90	1:3.3	1:2 – 1:10	113.8	-3.56	32.6	46	M40.5x0.5	141.3	505	331
3	Pyrite 5.6/120/0.33x V38 $\beta' = -0.33$	120	5.6	90	1:3	1:1.48 – 1:4.35	113.76	0.6	32.6	46	M40.5x0.5	153.4	635	449
4	Pyrite 5.6/120/0.5x V38 $\beta' = -0.5$	120	5.6	90	1:2	1:1.48 – 1:2.67	114.125	-0.54	32.6	46	M40.5x0.5	174.0	538	332
5	Pyrite 5.6/120/0.75x V38 $\beta' = -0.75$	120	5.6	90	1:1.33	1:1.14 – 1:1.48	115.02	-1.2	32.6	46	M40.5x0.5	205.4	490	252
6	Pyrite 5.6/120/1.0x V38 $\beta' = -1.0$	120	5.6	90	1:1	1:0.89 – 1:1.14	115.72	-1.78	32.6	46	M40.5x0.5	236.4	481	212

### ML2 M39x1/26" (Leica), High Resolution

7	Apo-Rodagon D2x 4.5/75 $\beta' = -0.5$	75	4.5	86.2	1:2	1:1.25 – 1:2.5	72.1	-2.2	30.4	50	M40.5x0.5	109.5	334	195
8	Apo-Rodagon D1x 4/75 $\beta' = -1.0$	75	4	82	1:1	1:0.8 – 1:1.25	62	-14.35	34.1	50	M40.5x0.5	136.9	285	114
9	Apo-Rodagon D 5.6/120 $\beta' = -0.5$	120	5.6	102	1:2	1:1.25 – 1:3	113	-3	30.7	50	M40.5x0.5	173.0	537	333

## Configuration Example: Line Scan Camera SK2048U3SH with Lens Apo-Rodagon D2 4.0/75mm for Field of View 60 mm

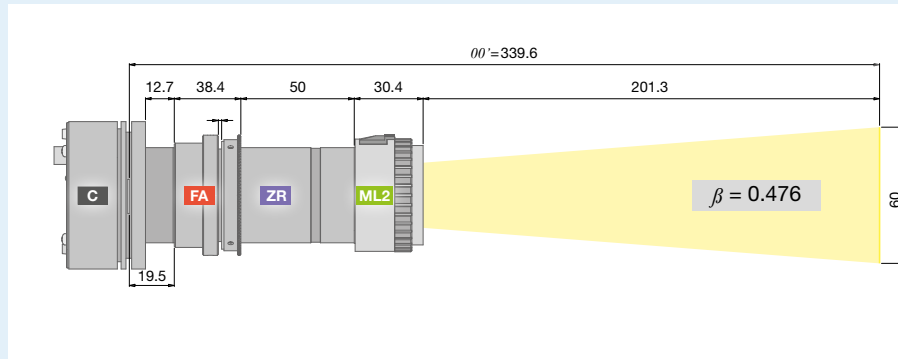

Sensor length: 28.67 mm  
 Field of View: 60 mm  
 Magnification  $\beta$  0.476  
 Focal length: 74.8 mm  
 Flange focal length: 72.1 mm  
 HH : -2.2 mm  
 OO : 229.6 mm  
 $\beta$  calculated from F2,  
 \*OO calculated from F5  
 (see page 67)

## System Components

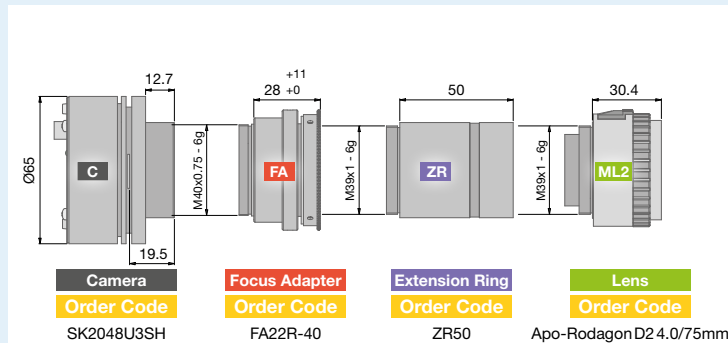

Scan and macro lenses require a focus adapter for focusing and one or more additional extension rings. Extension rings and the focus adapter together provide the tube length LT (see page 67, F4):

$$LT = 72.1 + 35.6 - 19.5 \text{ mm} = 88.2 \text{ mm} = 50 + 38.4 \text{ mm}$$

# Lenses: Macro Lenses



## Macro Lenses

Order Code	Focal length	F-number	Max. CCD sensor length	Optimum magnification	Magnification range	Flange focal length (s)	Principal point distance	Length	Outer diameter	Filter thread	Imaging at optimum magnification $\beta_o$		
	$f$ [mm]	$K$	$S$ [mm]	$\beta_o$	$\beta$	$s A$ [mm]	$HH$ [mm]	$LO$ [mm]	[mm]		Flange focal length ( $\beta_o$ )	Distance sensor to object	Distance lens to object
											$s A_{\beta_o}$ [mm]	$OO$ [mm]	$A$ [mm]

### ML3 F-Mount (bayonet Ø44 mm)

10	AF2.8/60D Micro	60	2.8	36	1:1	1:0.001 – 1:1	46.5	0	74.5	70	M62x0.75	106.5	240	59
----	-----------------	----	-----	----	-----	---------------	------	---	------	----	----------	-------	-----	----

### ML4 V-Mount V46, High Resolution

11	Apo-Rodagon HR 5.6/75 $\beta'$ -0.5	75	5.6	62	1:2	1:1.5 – 1:2.8	54	1.8	47	46	M37x0.75	92.5	348	208
12	inspec.x L 5.6/105 $\beta'$ -0.33	105	5.6	70	1:3	1:2 – 1:4	64.87	-7.37	72.5	61.4	M43x0.75	100.0	555	382
13	inspec.x L 5.6/105 $\beta'$ -0.5	105	5.6	70	1:2	1:1.5 – 1:2.5	65.05	-7.16	72.5	61.4	M43x0.75	117.7	467	277
14	inspec.x L 5.6/105 $\beta'$ -0.76	105	5.6	82	1:1.32	1:1.11 – 1:1.67	65.2	-7.5	72.5	61.4	M43x0.75	145.0	422	205
15	inspec.x L 5.6/105 $\beta'$ -1.0	105	5.6	70	1:1	1:0.85 – 1:1.2	65.54	-7.28	72.5	61.4	M43x0.75	170.9	414	171
16	inspec.x L 5.6/105 retro $\beta'$ -1.32	105	5.6	92	1:0.76	1:0.6 – 1:0.9	65.6	-7.5	72.5	61.4	M43x0.75	204.3	422	145
17	inspec.x L 5.6/105 retro $\beta'$ -2.0	105	5.6	140	1:0.5	1:0.4 – 1:0.65	65.99	-7.16	72.5	61.4	M43x0.75	276.7	467	118
18	inspec.x L 5.6/105 retro $\beta'$ -3.0	105	5.6	212	1:0.33	1:0.25 – 1:0.5	66.04	-7.37	72.5	61.4	M43x0.75	385.4	558	100

Detailed data sheets, up-to-date technical information, technical drawings including step files, accessories, extensive technotes section and FAQs: [www.sukhamburg.com](http://www.sukhamburg.com)



### Configuration Example: Line Scan Camera SK7500U3TO-XL with Lens inspec.x L 5.6/105 for Field of View 73.5 mm

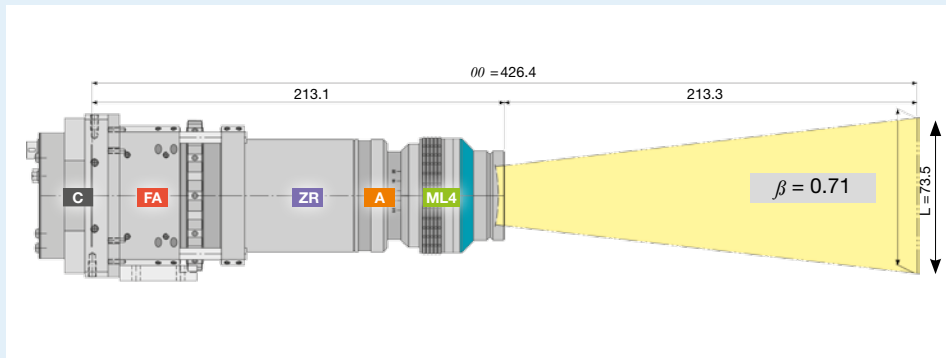

Sensor length: 52.5 mm  
 Field of View: 73.5 mm  
 Magnification  $\beta$ : 0.71  
 Focal length: 105 mm  
 HH: -7.27 mm  
 OO: 426.4 mm

$\beta$  calculated from F2,  
 \*OO calculated from F5  
 (see page 67)

### System Components

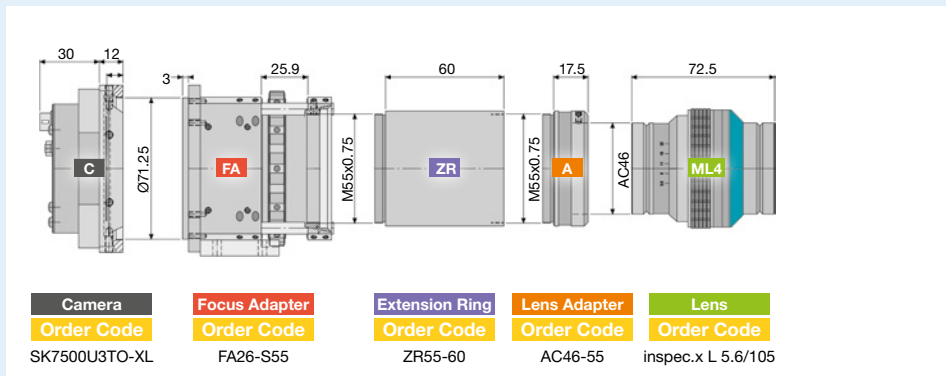

Scan and macro lenses require a focus adapter for focusing and one or more additional extension rings. Depending on the lens mount (V-Mount in this example), additional lens adapters may be necessary. Extension rings, the focus adapter, and the lens adapter together provide the tube length LT (see page 67, F4):

# Modular Scanner Systems

**Modular Scanner  
Systems for Industry  
and Laboratory**

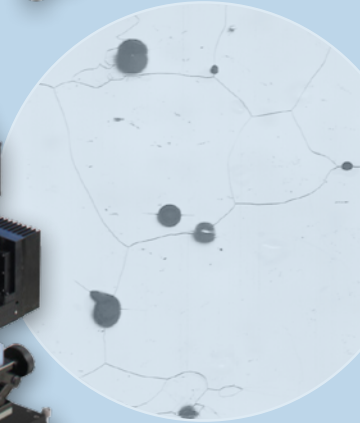
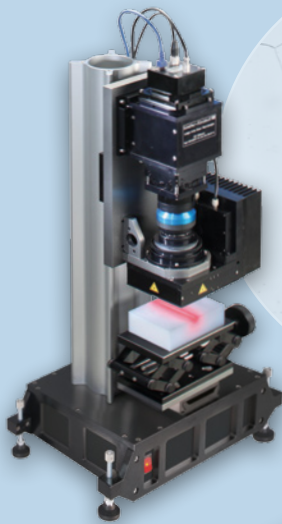

## ■ Modular Scanner Systems

Scanner Systems for Industry and Laboratory	78
Linear Scanner System for Measurement Tasks	80
Product Info: Corrosion Inspector	81
High End Imaging and Illumination Optics	84
Product Info: LASM for Ice Core Inspection	85
Color Scanner - Linear	87
Color Scanner - Rotation	88
Scanner Systems - Robot-Guided	89

# Scanner Systems for Industry and Laboratory

## Universal Scanner with linear and rotary drive

The scanner systems are stationary or portable devices for visualization of planar or cylindrical surfaces at high resolution. The resulting monochrome or color images can be evaluated or stored.

Modules to be configured according to the specific application:

- Sensor, Imaging Optics
- Illumination
- Motion Devices, Specimen Holder
- Software

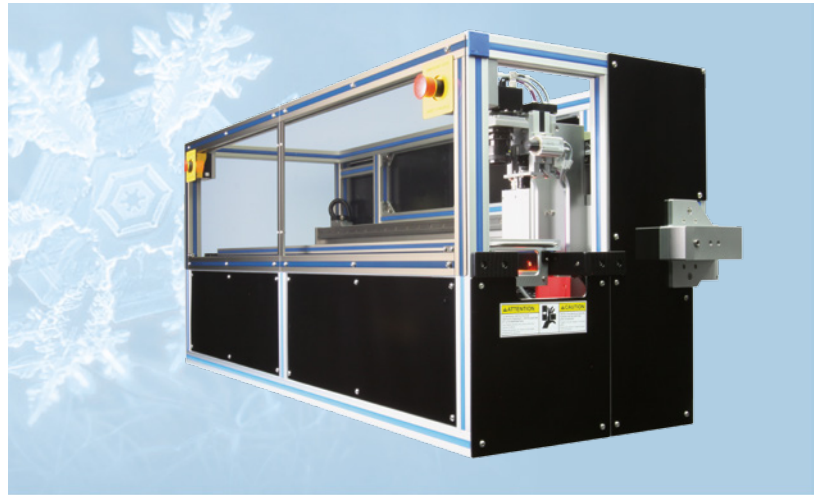

## Sensors and Imaging Optics

The sensor consists of a line scan camera and imaging optics. The particular configuration determines the field of view, the resolution and the grade of artefacts of the scanned images.

- Line scan cameras monochrome,
- 2048 to 8160 pixels
- Line scan cameras color,
- 3 x 2096 to 3 x 7600 pixels (RGB)
- Interfaces:
- USB 3.0, Gigabit Ethernet or GigE Vision
- Scan lenses
- High resolution scan and macro lenses
- Enlarging lenses
- Telecentric lenses

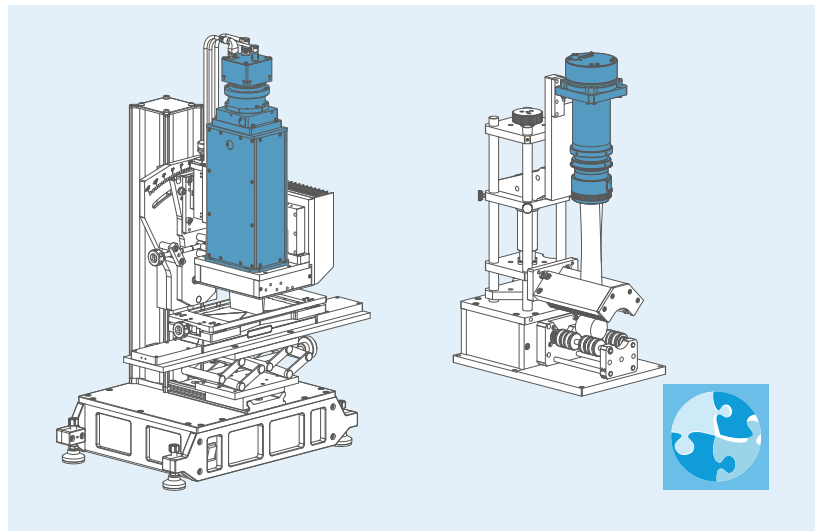

## Illumination

- Red or white LED light sources
- Coaxial line light
- Bright-field or dark-field illumination
- Diffuse light
- Backlight

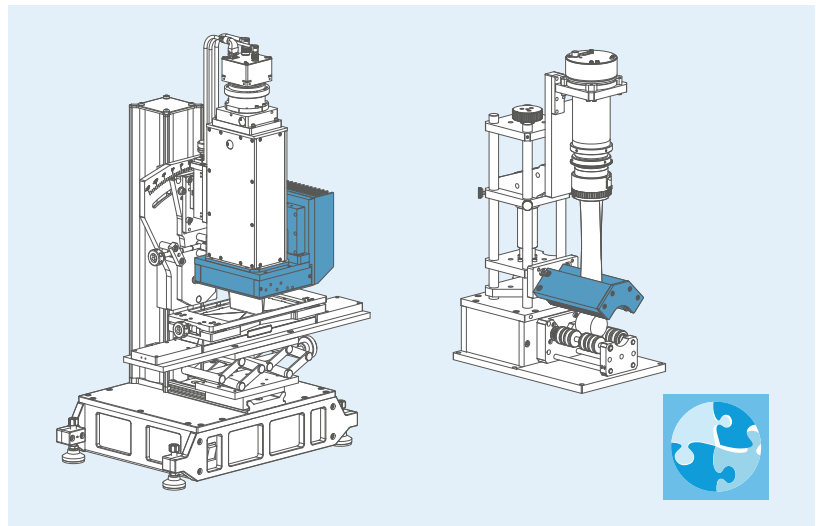

## Motion Devices

- Direct drives, load up to 3 kg, scan velocity up to 250 mm/s travel distance 45 to 230 mm
- Spindle drives, load up to 15 kg, travel distance up to 1200 mm, scan velocity up to 75 mm/s
- Rotary drives with pin holder for cylindrical objects  $\varnothing$  3 to 20 mm
- Rotary drives with roller support for cylindrical objects  $\varnothing$  24 to 200 mm

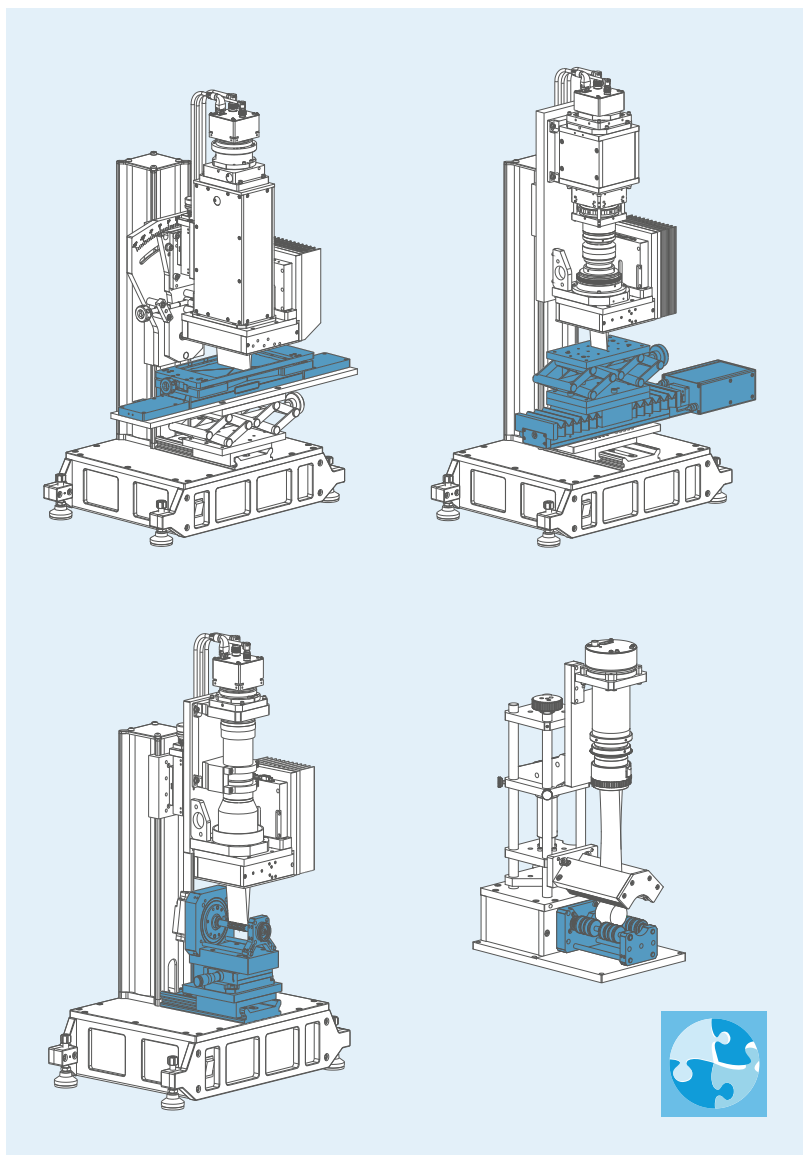

## Supplemental Options

### Angle of Incidence Adjustment

To enable the changeover between bright or dark-field illumination, the sensor mount is available with an adjustment mechanism for the angle of incidence.

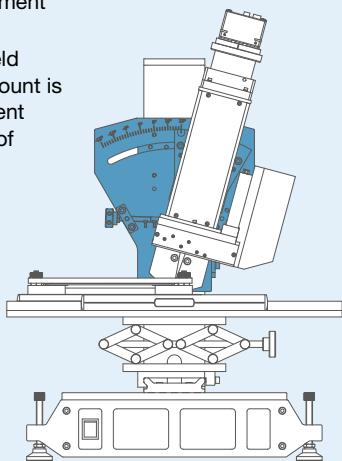

### Power-driven Working Distance Adjustment

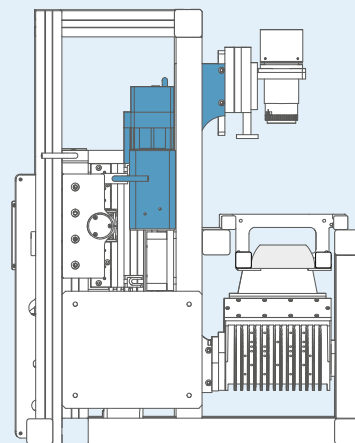

# Linear Scanner System for Measurement Tasks

- High speed translation stage with high positional accuracy.
- Coaxial LED line light, adjustable angle for bright or dark-field illumination
- Powerful application software for visualizing and measuring objects consisting of various materials.

Using the standard components of translation stage, illumination unit and line scan camera, Schäfter+Kirchhoff have developed scanner systems for the fast and objective measurement of objects of interest consisting of various materials.

One example is the Corrosion Inspector for evaluating filiform and other corrosion phenomena on coated test plates.

A standardized test plate of 200 mm length is scanned in 0.8 seconds. The resolution is 40 microns/pixel for the monochrome system and 22 microns/pixel for color.

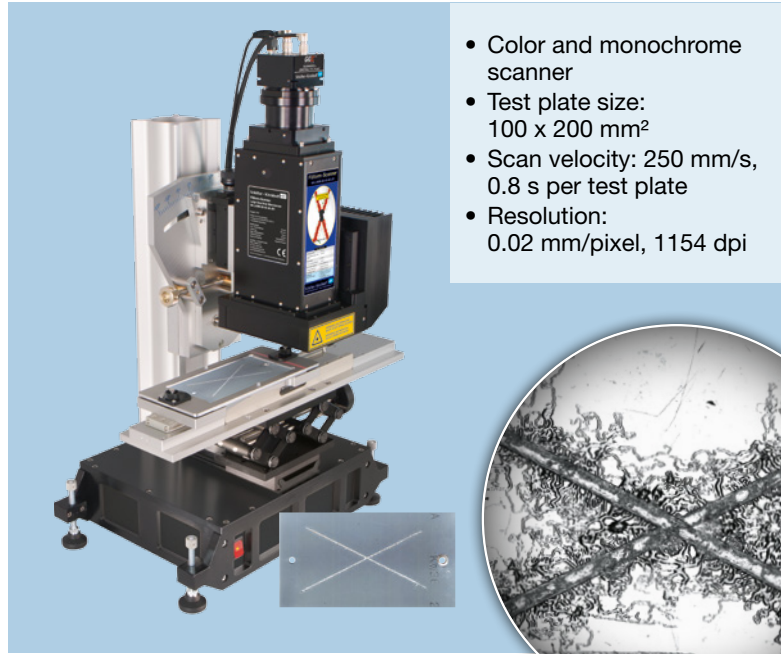

- Color and monochrome scanner
- Test plate size: 100 x 200 mm<sup>2</sup>
- Scan velocity: 250 mm/s, 0.8 s per test plate
- Resolution: 0.02 mm/pixel, 1154 dpi

Technical Data	
Resolution	22 µm/pixel (1154 dpi)
Scan width (Field of view)	90 mm
Scan length	variable, up to 200 mm
Max. scan velocity	250 mm/s. 1.2 s for 200 mm
Free working distance	49 mm
Depth of focus	3.3 mm at f# 8
Sensor	color line scan camera, 3x 4080 pixels, 10 x 10 µm <sup>2</sup> , line rate max. 4.8 kHz
Light source	coaxial LED line light, white 5000K
Dark-/bright-field adjustment	pivot angle -15° to +15°

## Software Functions SKan-CI

- Control of camera, lighting and motor stage
- Variable scan lengths, measuring in ROI
- Image processing, contrast enhancement, zoom.
- Filiform and red rust detection and evaluation
- Exports: original image, binary result image (png),
- Data export to Excel™, LibreOffice Calc

## Sample Application: Evaluation of Corrosion

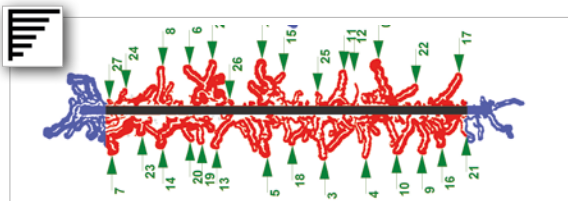

### Filament counting

- Ranking of filament lengths
- Evaluation according to GSB:  $H = Z / L$ ,  $F = l^*H$

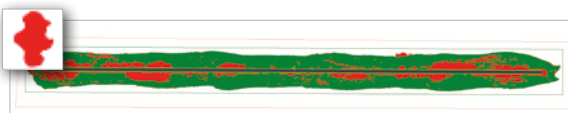

### Delamination and Corrosion

- Evaluation according to ISO 4628-8
- Using true color analysis for red rust detection
- Total corrosion area minus scribe line (mm<sup>2</sup>), marked red
- Separation of delamination area (mm<sup>2</sup>), marked green

## Sample Application: Measurement of Dimensions

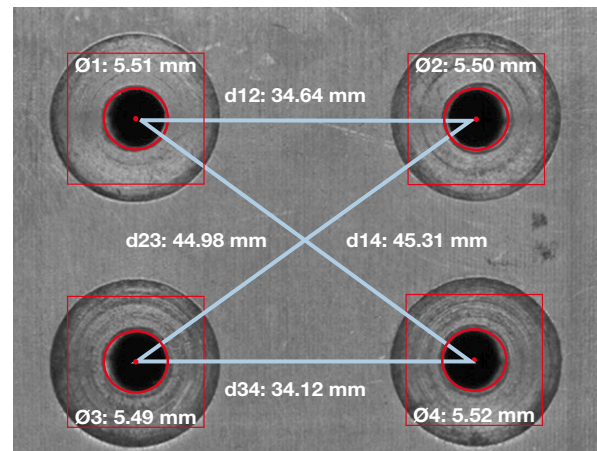

Using the linear scanner system from Schäfter+Kirchhoff, the measurement of distances, dimensions and positions of objects is possible.

- Ø1 - Ø4: measurement of diameters of holes
- d12 - d34: measurement of distances between the holes



# Product Info: Corrosion Inspector

## Measurement and evaluation of corrosion phenomena on coated test panels

The „Corrosion Inspector“ is a color scanner system for the fast and objective evaluation of filiform and other corrosion phenomena.

It scans a standardized testpanel and delivers a very high-contrast image with a resolution of 0.022 mm per pixel in only 1.2 sec. Using the automatic procedure, the evaluation of a sample panel, including documentation and image storage, is completed in 5 sec. In addition to the time savings, the system is characterized by the variety of implemented evaluation methods.

### Main features

- Color or monochrome scanner system
- Test panel size max. 100 mm x 200 mm
- Resolution 22 microns/mm, 1151 dpi
- Automatic and interactive measurement of corrosion phenomena, like area, width, filament length, red rust, delamination, multi-impact.

### Corrosion evaluations on corrosion test panels according to

- Filiform corrosion according to ISO21227-4
- Delamination and corrosion acc. to ISO 4628-8
- Cross-cut classification according to DIN EN ISO 2409
- Edge corrosion characteristic according to MBN 10494-6
- Blistering according to DIN EN ISO 4628-2
- Stone impact resistance test according to DIN EN ISO 20567-1
- Counting of all filaments, maximum length l, r
- Evaluation according to GSB, ACT II, Qualicoat

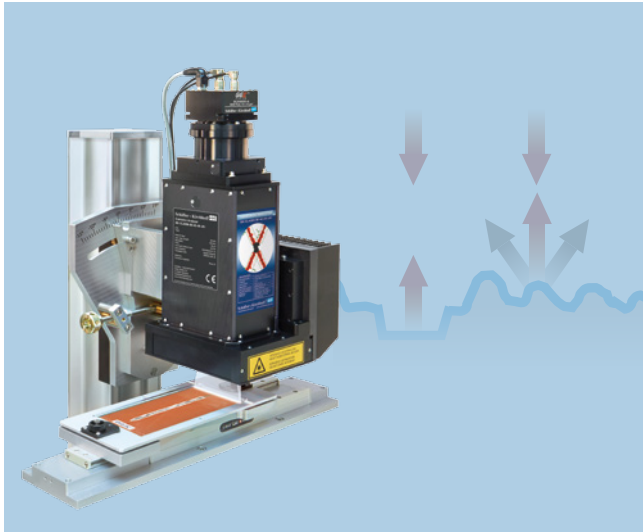

Detailed data sheets, up-to-date technical information, technical drawings including step files, accessories, extensive technotes section and FAQs: [www.sukhamburg.com](http://www.sukhamburg.com)



### Order Options

Pos.	Order Code	Color	Pixels	Resolution	Scan Width	Illumination
1	SK-LASM-80-40-49-J01	-	2048 pixels	40 µm / pixel, 650 dpi	80 mm	Red, 640nm
2	SK-LASM-C-90-22-J010	X	3 x 4080 (RGB)	22 µm / pixel, 1151 dpi	90 mm	White, 5000K

During the development of coating systems with improved corrosion resistance as well as for quality control of coated components, a large number of coated test plates are produced. These plates are scribed and then weathered in special climate chambers to start the corrosion. Conventionally, the resulting corrosion phenomena are then manually and visually evaluated, often using a magnification glass with an integrated scale, a very tedious work, which is error-prone and subjective.

The Corrosion Inspector scans a standardized test plate in 0.8 seconds with an optical resolution of 22 microns / pixel. The coaxial line illumination, either as a bright field or as a dark field, ensures the high contrast image of the corrosion structures. The software automatically detects the shape, length and corrosion

area and evaluates it according to the relevant standards.

The system was developed for rapid and objective corrosion evaluations with high sample throughput. The automatic evaluation including documentation in an image and Excel sheet takes 5 seconds. The system supports color and monochrome gray-scale images.

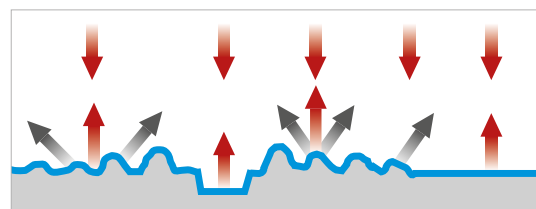

### Bright-field and dark-field illumination

To detect the relevant microstructures, bright-field or dark-field illumination is used.

With bright-field illumination, the light strikes the sample surface perpendicularly. Flat surfaces facing the sensor appear bright, the light hitting the edges is reflected away from the sensor. They appear dark.

With dark-field illumination, the light is directed onto the test surface with an angle. Only light from e.g. edges that cause the light to reflect into the sensor appear bright, flat surfaces e.g. facing the sensor appear dark.

### Analysis and control software SKan-CI

The software SKan-CI offers a simple control for the scanner system. After scanning the test sample, you have a wide range of image processing functions to get the best input for the analysis.

SKan-CI automatically recognizes a predefined set of scribe patterns and also automatically assigns, measures and ranks the corrosion phenomena. When desired, the interactive and manual measurement of corrosive phenomena can be performed by the operator.

The program saves the accepted corrosion analysis results as images and tabular data, together with the treatment and analytical processing information, for retrieval, comparison and documentation.

The software supports also the offline evaluation, without a connection to the Corrosion Inspector hardware. After loading a stored image, grayscale or color, the corrosion phenomena can be evaluated with all available methods. This allows an independent reanalysis or a new evaluation.

Technical Data	
Total measurement time	max. 5 s
Sensor	3 x 4080 (RGB) or 2048 pixels
Measurement area	max. 90 mm x 200 mm (RGB) max. 80 mm x 200 mm
Resolution	22 µm/pixel (1151 dpi) 40 µm/pixel (650 dpi)
Features	White Balance / Shading Correction, LUT
Interface	Gigabit Ethernet
LED line light	Integrated coaxial LED line light
Scan length	max. 200 mm
Scan velocity	max. 250 mm/s

### Cross-Cut Analysis

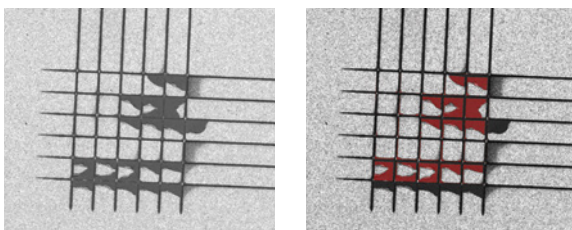

Cross-cut test, delaminated areas are marked in red.

Cross-cut analysis		Date: 29.04.2021 / 17:04:20	
Order:	Article		
Exposure time:	800h		
Operator:	John Doe		
Specimen ID:	01	SK angle: 0	
ID	A [mm <sup>2</sup> ]	AD [mm <sup>2</sup> ]	Gt
1	76.33	21.29	3.00

### Filiform Analysis

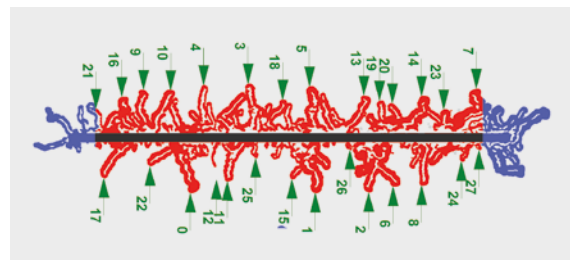
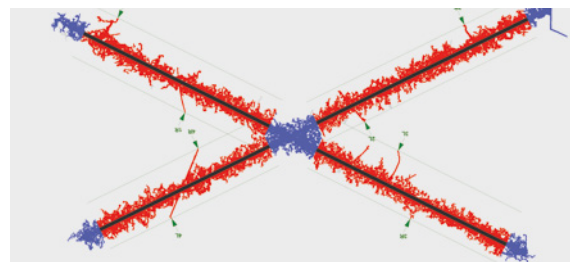

Automated evaluation of various corrosion parameters of different scribe pattern. Among other things, the infiltration area, the average infiltration width, length and number of threads are measured.

## Corrosion and Delamination

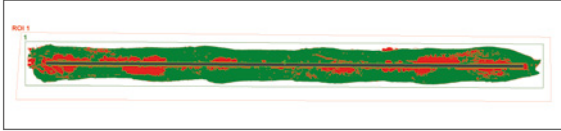
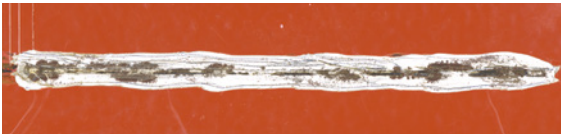

Korrosion Enthaftung Analyse  
 Auftrag: Freilacke  
 Belastungszeit: 1100h  
 Prüfer: Mustermann

Proben-ID:		70672B12	Scanzeit:		22.02.2018	10:23:52
Bemerkung: Testplatte						
ID	w [mm]	l [mm]	AC [mm <sup>2</sup> ]	C [mm]	AD [mm <sup>2</sup> ]	D [mm]
1	0.82	114.30	191.58	0.84	831.54	3.64
Gesamt	0.82	114.30	191.58	0.84	831.54	3.64

Automatic evaluation of corrosion and delamination using the color scanner system „Corrosion Inspector“. The Scanner detects red rust areas and measures the effected area as well as the delamination area. The scribe area is subtracted from both areas.

The sample shown in the picture was kindly provided by the company Freilacke, Döggingen, Germany.

**DIN EN ISO 4628-8:2005:**

*w* = scribe width, *l* = scribe length

$AI = w * l$  [mm<sup>2</sup>]

*AC* = corrosion area [mm<sup>2</sup>]

$C = AC - AI / 2l$  [mm]

*AD* = delamination area [mm<sup>2</sup>]

$D = AD - AI / 2l$  [mm]

## Edge Corrosion Analysis

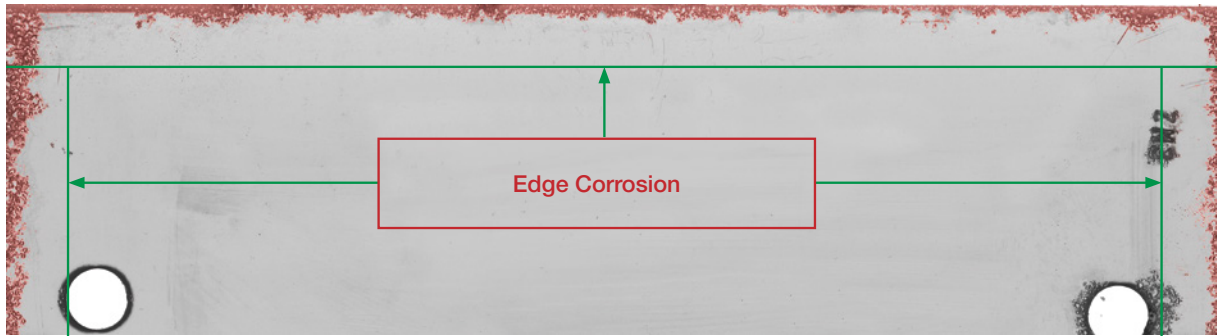

Edge corrosion, image and result superimposed, the corrosion areas are marked in red.

# High-End Imaging and Illumination Optics

- High resolution scan lenses
- High resolution telecentric lenses
- Coaxial directed LED light for bright or dark-field illumination

Technical Data	
Resolution	5 µm/pix (5080 dpi)
Scan width (Field of view)	41 mm
Scan length	150 mm
Max. scan velocity	59 mm/s
Scan duration for 80 x 200 mm <sup>2</sup>	2.5 s
Free working distance	49 mm
Depth of focus	0.16 mm at f# 8
Sensor	monochrome CCD, 8160 pixels, 5 x 5 µm <sup>2</sup> , line frequency max. 11.9 kHz
Light source	LED, directed coaxial line light, red 640 nm

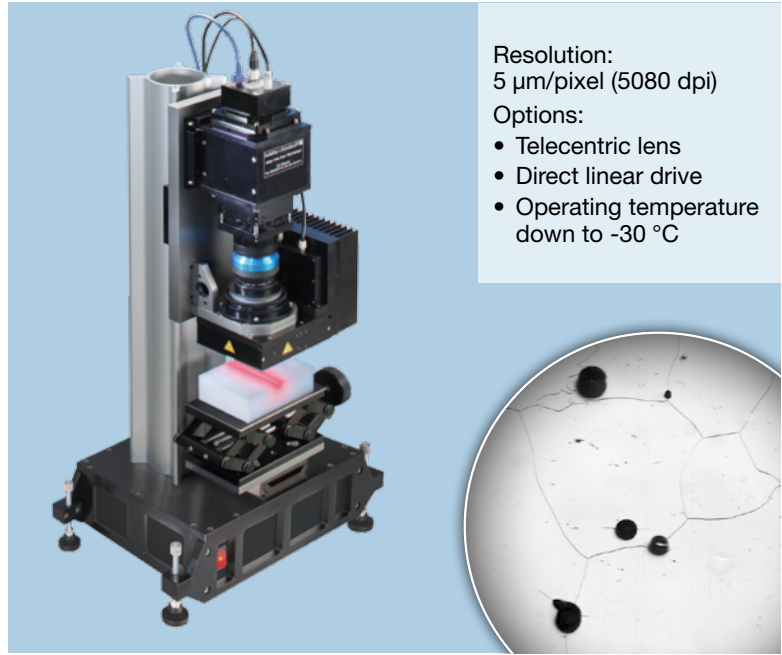

Resolution:  
5 µm/pixel (5080 dpi)  
Options:

- Telecentric lens
- Direct linear drive
- Operating temperature down to -30 °C

## Advantages of a telecentric beam path in distinction from common endocentric imaging

A telecentric lens views all points of the object directly from above. The resultant image is similar to a 2D technical drawing of the object. If variations in object height extend beyond the depth of focus then the image may be locally blurred but the object size remains constant. This makes it possible to determine the width of an indentation without interference by the vertical sidewalls.

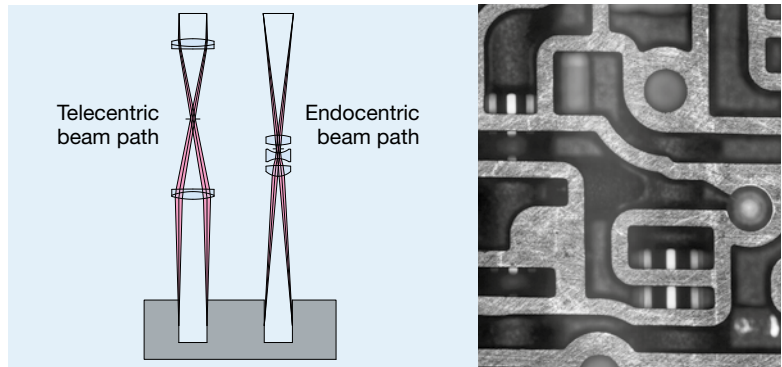

## Sample Application: Ice Core Research

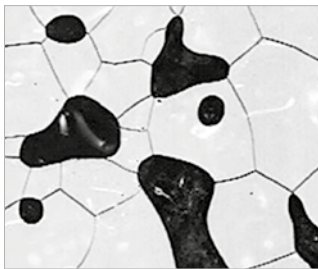

Scan of an ice core from a depth of 60 m under Antarctica. The light granular structure and dark gas bubbles are clearly discernable.

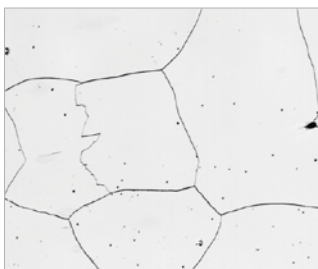

Scan of an ice core from 1035 m deep. The bubbles have been almost completely transformed into gas hydrates.

## Sample Application: Stent Research

Checking stent dimensions and surface quality

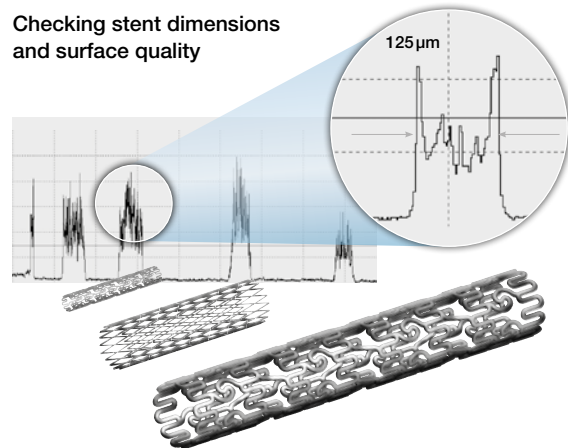

Surface quality and dimensions are detected using a telecentric lens and a line scan camera with integrated bright-field illumination. During stent rotation, the line scan camera rapidly records a planar 2D image of the unwound mesh structure.

# Product Info: LASM for Ice Core Inspection

## High resolution scanner system

The rapid analysis provided by the Large Area Scan Macroscope with a resolution of 5 µm has proven to be an essential tool for inspecting the microstructures of e.g. ice cores, both in the field and in the laboratory.

### Main features

- Main features
- Monochrome scanner system
- Scan width max. 41 mm
- Resolution 5 µm, 5080 dpi
- High resolution imaging of e.g. ice core samples
- Coaxial directed LED light for bright-field illumination
- Optional: Telecentric lens
- Optional: Direct linear drive
- Optional: Operating temperature down to -40 °C

### Scanner head

Time-consuming inspection using a microscope can be replaced by using the specially developed Large Area Scan Macroscope (LASM) with a monochrome Line Scan Camera. The Large Area Scan Macroscope consists of a Line Scan Camera, a high resolution lens as well as an illumination unit. The sample is imaged in reflection with a resolution of 5 µm (5080 dpi). The measuring width is 41 mm with a maximum scan length of 600 mm.

### Bright-field illumination

In order to capture the relevant microstructures, brightfield illumination is used. The light directed at the sample is reflected by surfaces parallel to the sensor. Light reflected from structured areas and edges is reflected away from the sensor and appears dark. Thus, also in the images obtained with this method, the grain boundaries appear as dark lines and gas inclusions appear as dark bubbles or spots.

### Undisturbed, high quality images in much less time

While for the image acquisition technique using a conventional microscope, thousands of images have to be stitched to form a complete picture, only two or three scans are necessary using the Large Area Scan Macroscope depending on sample dimensions. This reduces the imaging time considerably and obviates the alignment and matching of the many individual images of these sections, which requires significant computing time. Since the microscope method takes a long time, for scanning ice cores, all images are additionally taken with

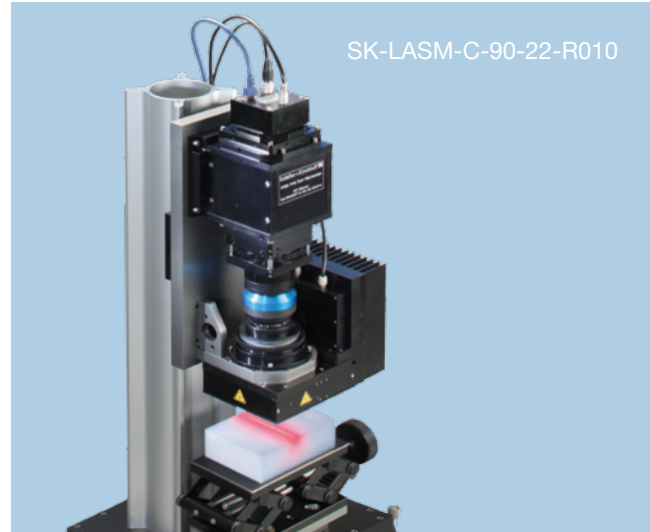

Detailed data sheets, up-to-date technical information, technical drawings including step files, accessories, extensive technotes section and FAQs: [www.sukhamburg.com](http://www.sukhamburg.com)



slightly different contrast due to the ongoing sublimation process, which also needs to be corrected for. In order to stitch the complete picture, the images also have to be corrected for vignetting and distortion. Using the Large Area Scan Macroscope, a shading correction done prior to scanning allows for evenly illuminated images that also do not show significant signs of distortion due to an excellent correction of the field of curvature. Since only two or three images are necessary to cover the whole sample the time required for stitching is severely reduced.

### Order Options

Pos.	Order Code	Color	Pixels	Resolution	Scan Width	Max. Scan length	Illumination	Special features
1	SK-LASM-C-90-22-R010	-	8160 pixels	5 µm / pixel, 5080 dpi	41 mm	150 mm	Red, 640nm	-
2	SK-LASM-005-3x41-600	-	8160 pixels	5 µm / pixel, 5080 dpi	41 mm (single scan), up to 100 mm with three scan passes	600 mm	Red, 640 nm	Mounted on granite plane

## Product Info: LASM for Ice Core Inspection

### High resolution scanner system

#### One of many applications: Ice core inspection

The figure on the right shows the scan of an ice core sample. The ice core image from 60 m depth shows well defined grain boundaries (dark lines) and pores.

The short time necessary to acquire a complete picture (from >1 h to about 1 – 2 minutes) of an ice core allows for many more samples to be taken during the limited time available in the field, providing a much more detailed picture of the microstructure within the whole ice cores. Due to the short measuring time, many more samples can be measured from one ice core using LASM. Since the image acquisition is so fast, the ice core samples can even be scanned several times to document the sublimation process (for example right after microtoming, and some time later) which is not possible using the microscope technique.

A stratigraphic image that supports dating the ice cores can be obtained using the Intermediate Layer Core Scanner (ILCS).

#### High resolution imaging in harsh environments

As the analysis of the microstructure needs to be done in the field during drilling as well as in the lab, the line scanners developed for analyzing ice cores need to be robust and insensitive to the harsh environment. The components used (mechanical, optical as well as electrical) are designed to work properly at temperatures down to  $-20^{\circ}\text{C}$  /  $-40^{\circ}\text{C}$ . Mobile scanner systems (like e.g. SK-LASM-41-05-49-J01) are stable and robust enough to endure the long and bumpy ride to and from the drilling site and have been used in the field in Antarctica as well as in Greenland multiple times. Whenever drilling is not ongoing they are used in the lab, e.g. at AWI in Bremerhaven.

More information on microstructure mapping of ice cores can be found on <https://www.awi.de/forschung/geowissenschaften/glaziologie/werkzeuge/microstructure-mapping.html>.

DEEPICE Project

<http://pastglobalchanges.org/science/end-aff/deepice>

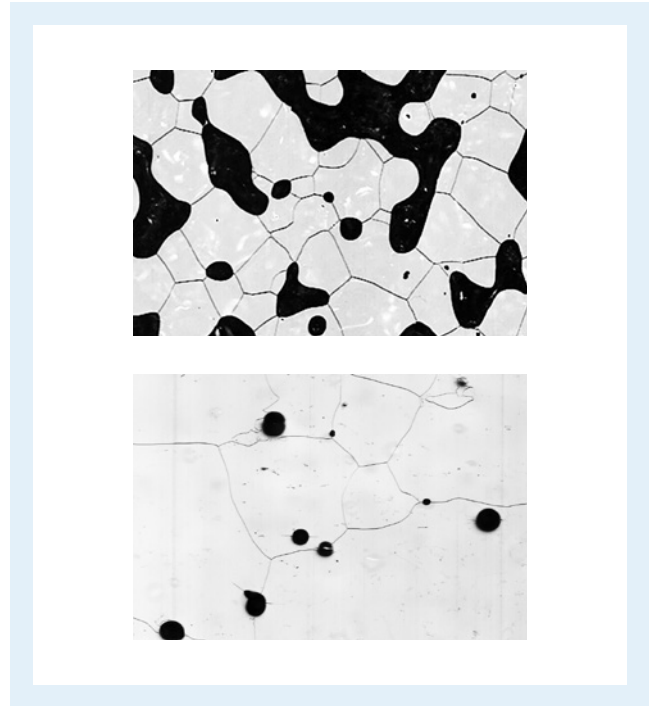

# Color Scanner – Linear

## for evaluation of corrosion test plates

- Color sensors from 3x 2096 pixels (RGB) up to 3x 7600 pixels (RGB)
- LED line light, white
- Scan width up to 800 mm
- Color calibration based on an IT8-target

The variety of color line scan cameras allows the assembling of color scanners for surface inspection of planar objects in a wide range of scan widths and resolutions. Typical applications are the inspection of wood surface, scanning of books and documents, or quality control of printings.

The customers requirements decide about the used components of camera, lens, illumination unit, and the linear motor axis.

For example, a wood plate of 20 mm width can be scanned with a resolution of 20 microns per pixel, or 1270 dpi.

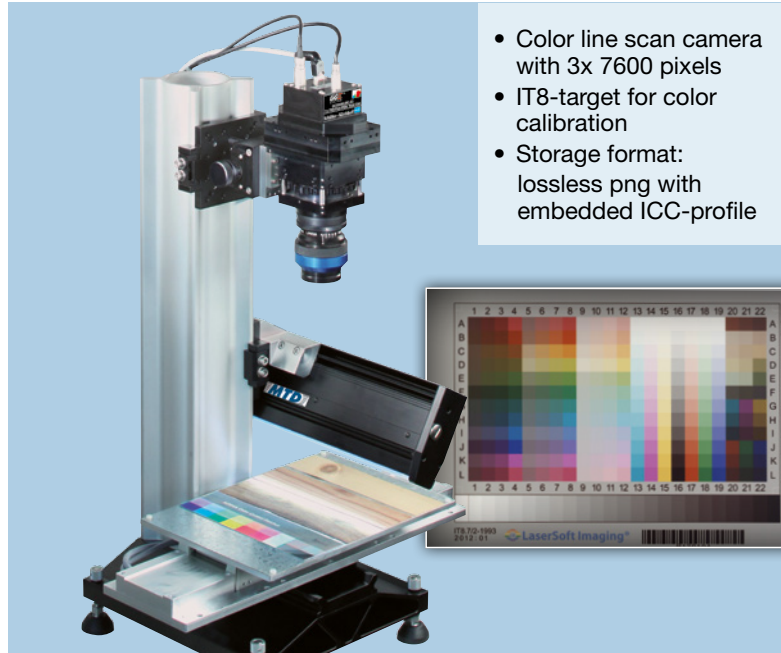

- Color line scan camera with 3x 7600 pixels
- IT8-target for color calibration
- Storage format: lossless png with embedded ICC-profile

## True color imaging technologies

### White balance

A scan of a white template over a defined distance is performed to produce a 2D image. The software calculates a reference curve to correct for variations in brightness. The resulting lookup table is stored in the flash memory of the camera.

### Color calibration

For effective color reproduction by the entire scanner, a standardized color calibration is necessary using an IT8-target of a defined color palette. The IT8-target is imaged by the scanner and the software calculates an ICC-profile on the basis of defined reference values.

Subsequent scans can use this profile to produce images with reliable color fidelity.

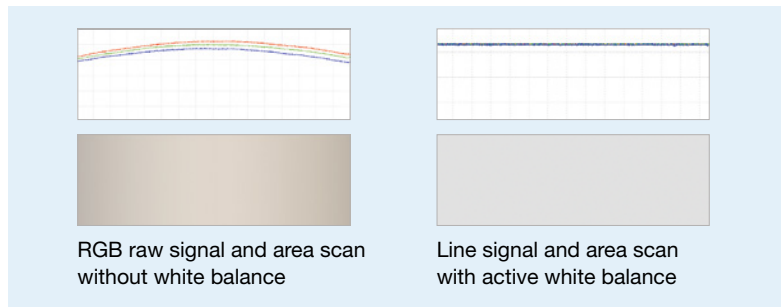

RGB raw signal and area scan without white balance

Line signal and area scan with active white balance

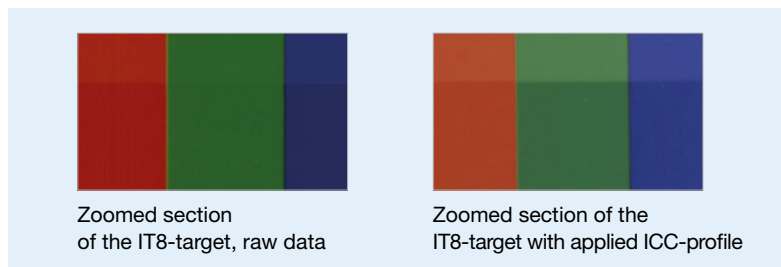

Zoomed section of the IT8-target, raw data

Zoomed section of the IT8-target with applied ICC-profile

## Sample Application: Wood Surface Inspection

Artwork masters for interior decoration (laminated or tilework floor)



### Technical Data

Resolution	30.0 $\mu\text{m}/\text{pix}$ (850 dpi)
Scan width (Field of view)	228 mm
Scan length	variable, up to 2000 mm
Max. scan velocity	140 mm/s
Scan duration for 80 x 200 mm <sup>2</sup>	15 s
Free working distance	405 mm
Depth of focus	2.0 mm at f# 8
Sensor	Color CCD, 3 x 7600 pixels (RGB), 9.3 x 9.3 $\mu\text{m}^2$ , line spacing 9.3 $\mu\text{m}$ , line frequency max. 4.95 kHz (GigE) or 6.1 kHz (USB 3.0) frequency max. 4.95 kHz (GigE) or 6.1 kHz (USB 3.0)
Light source	directed LED line light, white, 5000 K

# Color Scanner – Rotation

## Scanning of lateral surface of cylindrical objects

- Color sensors up to 3x 2096 pixels (RGB)
- LED line light, white
- Object diameter 10 mm up to 50 mm
- Scan width up to 100 mm
- Color calibration based on an IT8-target

When scanning cylindrical objects, the line scan camera has a substantial advantage over other imaging methods using a matrix camera, for example. When focused on the zenith of the round object, the line scan camera delivers sharp, distortion-free images of the lateral surface as the cylinder is rotated.

Schäfter+Kirchhoff has capitalized on this line scan advantage to develop the Core Plug Scanner. Geological exploration for oil, gas, ores or minerals does generate a large number of drill core plugs for assessment. The lateral surfaces of the cores require visualization in high quality with the subsequent storage of lossless data in digital form.

A color line scan camera with 3x 2096 pixels is used to generate the images. Prior color calibration of an IT8-target guarantees the capturing of the core plug surface in true color.

The USB 3.0 interface of the camera allows the scanner to be controlled with a notebook and predestines the system for mobile use. The device is also delivered in a sturdy aluminium case for this purpose.

The roller drive facilitates the rapid and easy loading of the drill core samples.

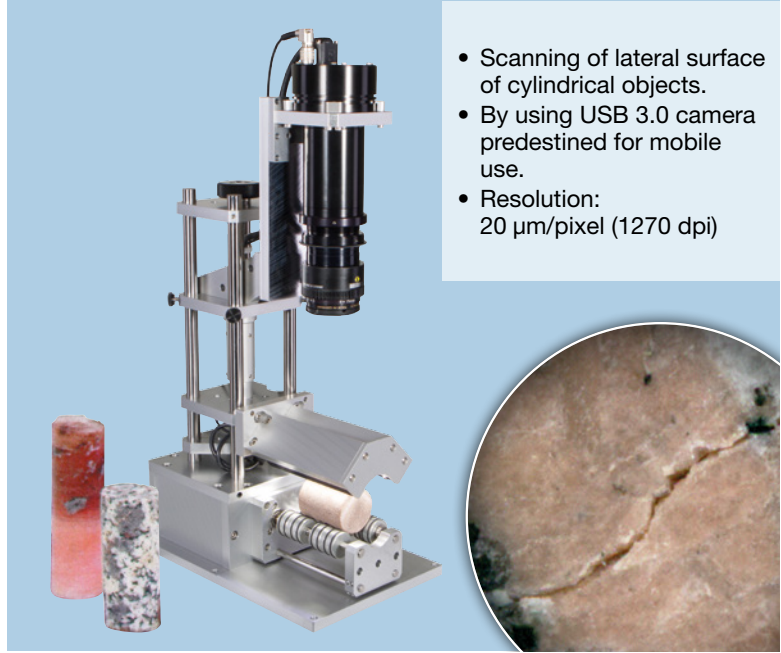

- Scanning of lateral surface of cylindrical objects.
- By using USB 3.0 camera predestined for mobile use.
- Resolution: 20 µm/pixel (1270 dpi)

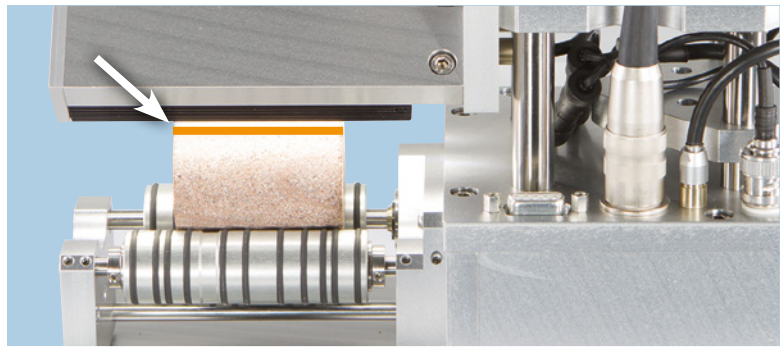

## Sample Application: Core Plug Scanner

Imaging of a mineral core, scanned using the Core Plug Scanner from Schäfter+Kirchhoff.



### Technical Data

Resolution	20 µm/pix (1270 dpi)
Scan width (Field of view)	41.8mm
Scan range	360°
Max. scan velocity	66mm/s
Scan duration for Ø 25 mm	1.2 s
Depth of focus	0.2 mm at f# 8
Sensor	CCD color line scan camera, 3 x 2096 pixels, 14 x 14 µm <sup>2</sup>
Light source	LED line light, white, 5000K
Rotation	Roller drive
Application	Exploration of oil, gas, coal, ores, and minerals



# Scanner Systems – Robot-Guided

## Flexible scanning of curved surfaces

The robot-guided line scan camera consists of a sensor head with a high-resolution line scan camera (monochrome or color) and integrated line illumination, that is mounted on a robot arm.

### Main features

- Color or monochrome scanner system
- Resolution 22 microns/mm, 1151 dpi
- Corrosion evaluations on car rims or wheel segments, as well as on corrosion test plates.
- Partial scanning of installed parts on cars, e.g. wheels, doors, bumpers, etc.
- Imaging and optical quality control of any kind of coatings.
- Collaborative robot meets safety requirements ISO 10218-1 and ISO/TS15066 for human-robot interaction



Detailed data sheets, up-to-date technical information, technical drawings including step files, accessories, extensive technotes section and FAQs: [www.sukhamburg.com](http://www.sukhamburg.com)



The robot arm executes a scanning movement on a programmed path over the surface. The path programming is easy possible by manually setting of few waypoints. At the beginning of the movement, the control unit of the robot arm sends a trigger signal to the camera.

The camera starts the image data transfer to the computer with an adjustable delay. During the movement, the line signals are assembled one by one into a 2D image in the computer's RAM.

At the end of the movement, the computer displays the image on the monitor. The image processing and evaluation can be applied to the entire image after the scan is finished, or frame-by-frame already during the scanning process.

### Unlimited freedom with high safety

Thanks to a 6-axis robot arm, there are almost no limits to the scanning of surfaces. Whether strongly curved, slightly twisted or a flat surface - all this is no handicap for the robot arm. This great freedom is supported by intuitive operation for creating the path for the scanning process. Waypoints can be set either by hand or in an easy-to-use software interface. When using the software interface, the robot arm can be controlled with high precision in both the position and angle of the sensor head.

The operator also benefits from the high safety of the robot arm thanks to force-torque sensors that comply with the standards DIN EN ISO 10218-1 as well as the requirements of DIN ISO/TS 15066. If too much force is applied, the robot arm switches off automatically. The operator must manually confirm the safety status in order for the robot to resume its work. This ensures safe operation in cooperation with humans.

### Bright-field and dark-field illumination

To detect the relevant microstructures, bright-field or dark-field illumination is used.

With bright-field illumination, the light strikes the sample surface perpendicularly. Flat surfaces facing the sensor appear bright, the light hitting the edges is reflected away from the sensor. They appear dark.

With dark-field illumination, the light is directed onto the test surface with an angle. Only light from e.g. edges that cause the light to reflect into the sensor appear bright, flat surfaces e.g. facing the sensor appear dark.

The sensor head on the robot arm can be precisely adjusted in angle and can also precisely maintain this angle over a distance section. If the surface changes, the angle can be easily readjusted in the path planning.

### Order Options

Pos.	Order Code	Color	Pixels	Resolution	Illumination
1	SK-LASM-C-90-22-R010	-	3 x 4080 (RGB)	22 µm / pixel, 1151 dpi	White, 5000 K
2	SK-LASM-M-90-11-R010	X	8160 pixels	11 µm / pixel, 2388 dpi	Red, 640 nm



## Further Product Catalogues:

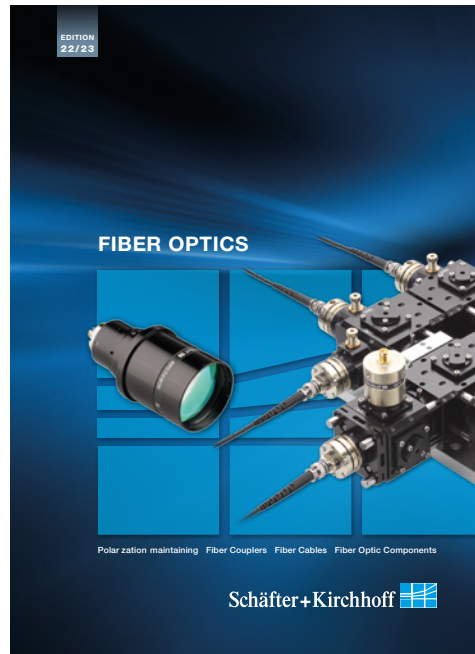

<https://www.sukhamburg.com/support/catalogue.html>

Contact details:

Schäfter + Kirchhoff GmbH  
Kieler Str. 212  
22525 Hamburg  
Germany

Tel: +49 40 85 39 97-0  
Fax: +49 40 85 39 97-79

[info@sukhamburg.de](mailto:info@sukhamburg.de)  
[www.sukhamburg.com](http://www.sukhamburg.com)